

QUIC-ACCESS® SCBA CABINETS
MODELS MMWC-1 AND MMWC-2
PARTS AND INSTRUCTION MANUAL

ZICO

5005PM2

REV. 5-5-20



Features:

- Constructed of UV-stabilized ABS plastic with highly visible “safety yellow” doors
- Model MMWC-1 stores one air cylinder or SCBA air pack. Model MMWC-2 stores two. Stick-on labels are provided to indicate minutes duration of SCBA(s) mounted inside.
- Bulb seal gasket locks out moisture and dirt, while thermoplastic hinges and latches are highly resistant to corrosive chemicals and ultraviolet exposure. Handle is molded into the door.
- Windows allow for external visual inspection of contents and air cylinder pressure readings.

Note: Cabinet Mounting Brackets and/or WALKAWAY Spring Clip Brackets, which hold cylinders inside the cabinet, are sold separately. See below.

MODEL NO.	DESCRIPTION	OUTSIDE DIMENSIONS W X H X D	INSIDE DIMENSIONS W X H X D	WT ./@ IN LBS.
MMWC-1	Single SCBA Cabinet	21-1/2" x 32-1/2" x 14-1/4"	16" x 29" x 13"	20.3
MMWC-2	Double SCBA Cabinet	32" x 32-1/2" x 14-1/4"	27" x 29" x 12-3/4"	28.6

**Cabinet Mounting Bracket
Model CMB**

For use with any make and model of SCBA up to 10” in diameter or 28” in circumference.

Cylinder is held in place by nylon straps with a quick-release buckle.

PVC-coated yellow for maximum durability.

Pre-drilled holes for easy mounting.

14-3/4" L x 6-1/2" W x 5-5/8" D



**WALKAWAY Spring
Clip Brackets**

Highly customizable. Must be adjusted to fit specific make/model of air cylinder being stored. Please call 1-800-711-FIRE with air cylinder information for further assistance.

Cylinder is held in place by hardened steel spring clips.

Multiple protective coatings to choose from.



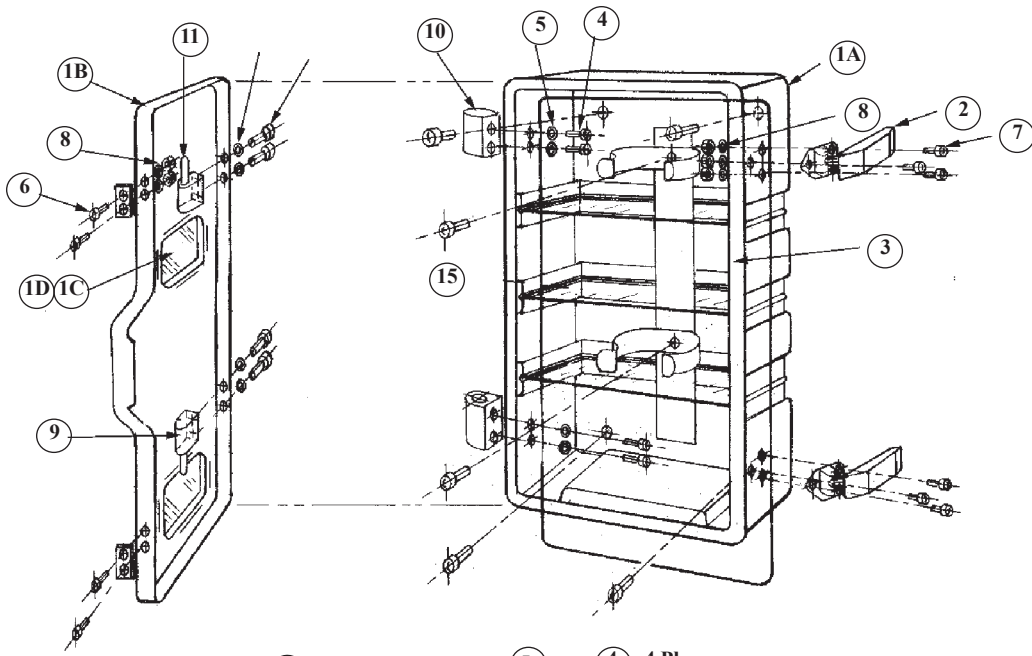

**MMWC-1 cabinet with
WALKAWAY® bracket**

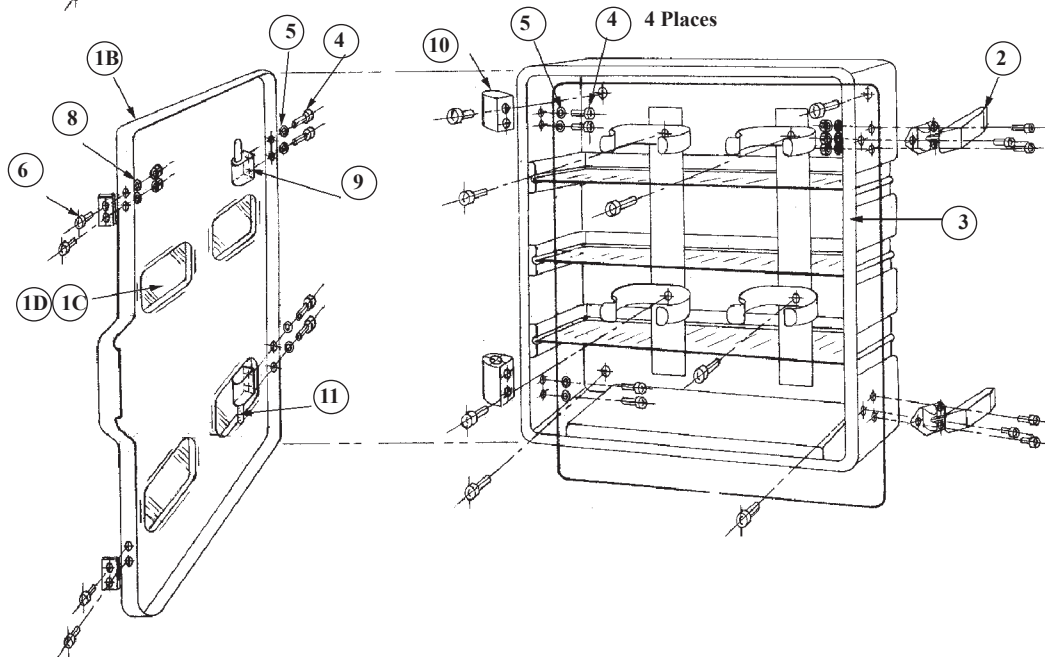

**MMWC-2 cabinet with
WALKAWAY® brackets**

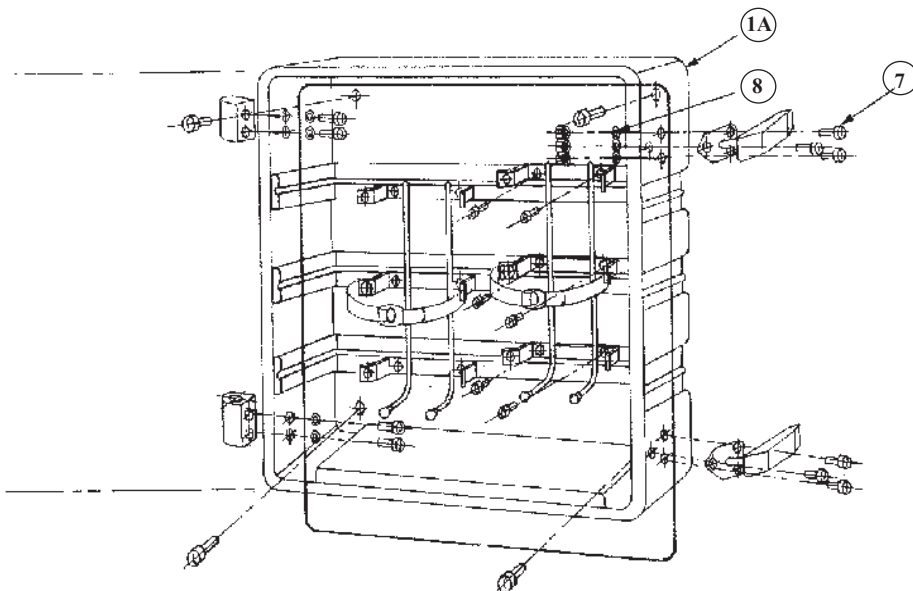

**MMWC-2 Cabinet with
CMB brackets**

ITEM NO.	DESCRIPTION	PART NO.	QTY.
1	Cabinet, door & windows	5005-110-105	1
1A	Cabinet, molded ABS	5005-110-109	1
1B	Door, molded ABS	5005-110-110	1
1C	Window, clear polycarbonate	5005-110-107	2
1D	3M adhesive for window	5005-000-120	1 tube
2	Latch, ABS	5005-000-130	2
3	Gasket, bulb seal	5005-000-125	1
4	1/4-20 x 7/16 pan hd m/s	9110-212507	8
5	1/4 ID flat washer	9114-112500	8
6	3/16 pop rivet, .188/.250	9260-001802	4
7	3/16 pop rivet, .375/.500	9260-001806	6
8	.191 ID flat washer	9114-101800	10
9	Hinge attached to door	5005-000-115	2
10	Hinge attached to cabinet	5005-000-116	2
11	1/4 x 3-1/4 drive pin	9045-112552	1
14	Label, 15-30-45-60 minute	5005-000-150	
16	Opt. Label, "Emergency Respirator"	5005-000-160	
	Opt. Label, "Emergency Equipment"	5005-000-165	
	Opt/ Label. "Protective Clothing"	5005-000-170	
	Opt. Label, " Self Contained Breathing Apparatus	5005-000-175	

I. SCBA Bracket Installation Instructions

Note: A mounting bracket is required in order to securely store an air cylinder or air pack inside of an MMWC cabinet. Sold separately, see Page 1 for details.

1. Secure each air cylinder/air pack in its designated SCBA bracket (CMB or WALKAWAY)
2. Place complete cylinder/pack and bracket into the cabinet. Position so that each cylinder valve assembly rests upon the bottom shelf.
 - a. If only one SCBA is to be stored, center the bracket in the cabinet
 - b. If using the MMWC-2, two air packs may be mounted side-by-side, an air pack and a spare cylinder, or two spare cylinders
3. When satisfied with layout and positioning, mark the position of the bracket(s) within the cabinet, then remove the cylinders/packs and set them aside.
4. Return brackets to their marked positions, then, using the bracket(s) as a stencil/guide, mark the location of the mounting holes on the back of the cabinet. Remove brackets.
 - a. At least two mounting holes must fall on the raised "ribs" in the molded plastic
 - b. For WALKAWAY brackets, mark a minimum of two mounting holes (5/16" holes down the center of the backplate)
 - c. For CMB brackets, mark the location of at least four of the bracket's pre-drilled, 5/16" holes
5. Drill 5/16" holes in the cabinet where previously marked.
- 6 Mount the brackets to the cabinet with 1/4-20 hardware (not included). Bolt head should be on inside of the cabinet.

II. SCBA Cabinet Mounting Instructions

1. Position cabinet at desired height on desired mounting surface. Mark location of cabinet .
2. Choose two to four mounting points where cabinet is flush with mounting surface. Ideally, there will be one mounting hole in each of the four corners. Mark.
3. Remove cabinet from mounting surface and drill 5/16” holes at each marked mounting point. If sheet metal or wood screws are to be used, use a 1/4” drill instead.
4. Place cabinet back in position on the mounting surface. Use new holes in cabinet as a stencil/ guide, level, and mark locations on the mounting surface. Remove cabinet.
5. Drill 5/16” holes into mounting surface at marked locations (1/4” if using sheet metal/wood screws)
6. Fasten the cabinet to the mounting surface using your desired mounting hardware (not included)
7. Cylinders/air packs may now be placed into their brackets. Masks may be stored in a pouch on the bottom shelf.



Ziamatic Corp.

10 West College Avenue, P.O. Box 337, Yardley, PA 19067-8337 • (215) 493-3618 • FAX: (215) 493-1401

*ZICO is a registered trademark for fire, safety and marine products made by Ziamatic Corp.

www.ziamatic.com

CALL TOLL FREE: 800-711-FIRE

Copyright Ziamatic Corp. 5-20