

**Note:** This manual should be used alongside manual 3097PM6. For all part numbers in parenthesis, refer to Chart 1 HLAS Parts Listing on page 26 of that manual. There is a separate Parts Listing in this manual that specifies the parts for this upgrade. Figures 19 and 21 in this manual are the same as those in manual 3097PM6.

**WARNING:** The Hydraulic system is a closed loop system. Hydraulic fluid in this system may be under pressure. Always wear safety glasses and protective clothing (Personal Protective Equipment (PPE)). No one, other than a qualified hydraulic pump technician should attempt to remove any fittings or hoses from the system. The system contains one orifice (30) which is restricted to .025" (see Figure 19, page 2). Removal of this fitting or not properly disconnecting the hydraulic lines could cause bodily injury.

**IMPORTANT:** Before removing old components, note the paths of the hydraulic lines and wiring. This is critical to ensure that after new components are put into place normal operation of moving parts will not pinch or cut hydraulic lines or wiring.

## **I. Hydraulic Fluid Specifications**

- SAE 5W20, or other clean hydraulic fluid with a viscosity of 150 to 300 SUS at 100 degrees Fahrenheit.
- System capacity (dry) is 50 ounces.

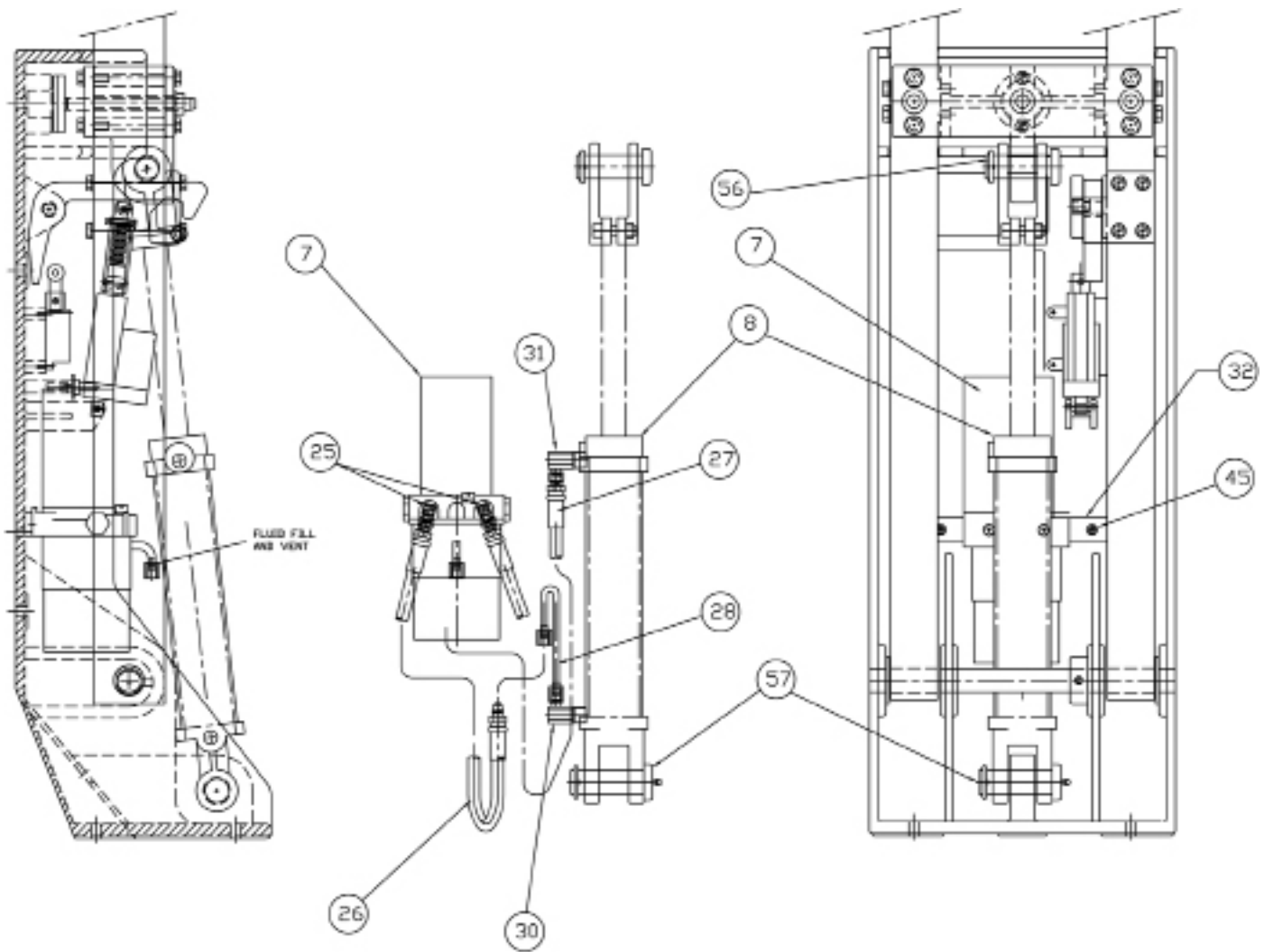
## **II. Removal of Old Hydraulic Power Unit**

1. If possible, lower the booms and remove the ladder(s) (HLAS) or the portable tank system rack (HPTS). Otherwise, the ladder(s) or HPTS rack must be carefully removed in the upright position.
2. Disconnect the power going to the unit and unplug the power units.

**CAUTION:** The hydraulic lines must be disconnected slowly to relieve pressure within the lines. Hydraulic fluid may spray out of the fittings. Wear proper Personal Protective Equipment (PPE) while doing this.

*Note:* Have containers and rags ready to catch any leaking fluid from the disconnected hydraulic lines.

3. Slowly disconnect the Hydraulic Line (27) to relieve pressure from the Hydraulic Cylinder (8), Fitting (31). See Figure 19, page 2.
4. Disconnect the hydraulic lines from the Hydraulic Cylinder (8).
5. Take note and tag the order of the hydraulic lines as they are attached to Elbows (25) before removal. Slowly disconnect the hydraulic lines from the Elbows (25) on the front side of the pump. See Figure 101, page 3.
6. Remove the two bolts (45) and two lock washers (73) holding the power unit mounting bar to the Base Casting (1). See Figure 101, page 3.



**FIGURE 19  
HYDRAULIC SYSTEM COMPONENTS**

ITEM	PART NO.	DESCRIPTION	QTY.
7	3097-500-192	Power Unit, Hydraulic	1
8	3097-500-198	Hyd Cyl. 2.5" x 8" Stroke	1
25	3097-500-135	Elbow, PU to Hose (7/16-20)	2
26	3097-500-133	Hyd Flex Hose-Short - 20 3/4"L	1
27	3097-500-132	Hyd Flex Hose-Long - 29"L	1
28	3097-500-134	1/4 OD Hyd Line Assy.	1
29	3097-500-129	Hydraulic Fluid, Qt.*	2
30	3097-500-125	Elbow/Adapter w/Orifice	1
31	3097-500-124	Elbow/Adapter	1
32	3097-500-190	Mtg. Bar, Power Unit	1

ITEM	PART NO.	DESCRIPTION	QTY.
45	9010-103712	Screw, 3/8-16 x 3/4" Hex Hd SZP	4
48	3097-500-194	Plastic Elbow	1
51	0000-025-107	Boot, Red	2
60	9070-001524	Cotter Pin 5/32 x 1-1/2	2
71	3097-500-199	Plug, Shipping	1
73	9014-203700	Lockwasher, 3/8 ID SZP	4
150		Breather Plug (incl. with Hydraulic Power Unit)	1
151	000-000-209	Ring Terminal, Yellow, 5/16" 10-12 AWG	2

\*Not Shown.

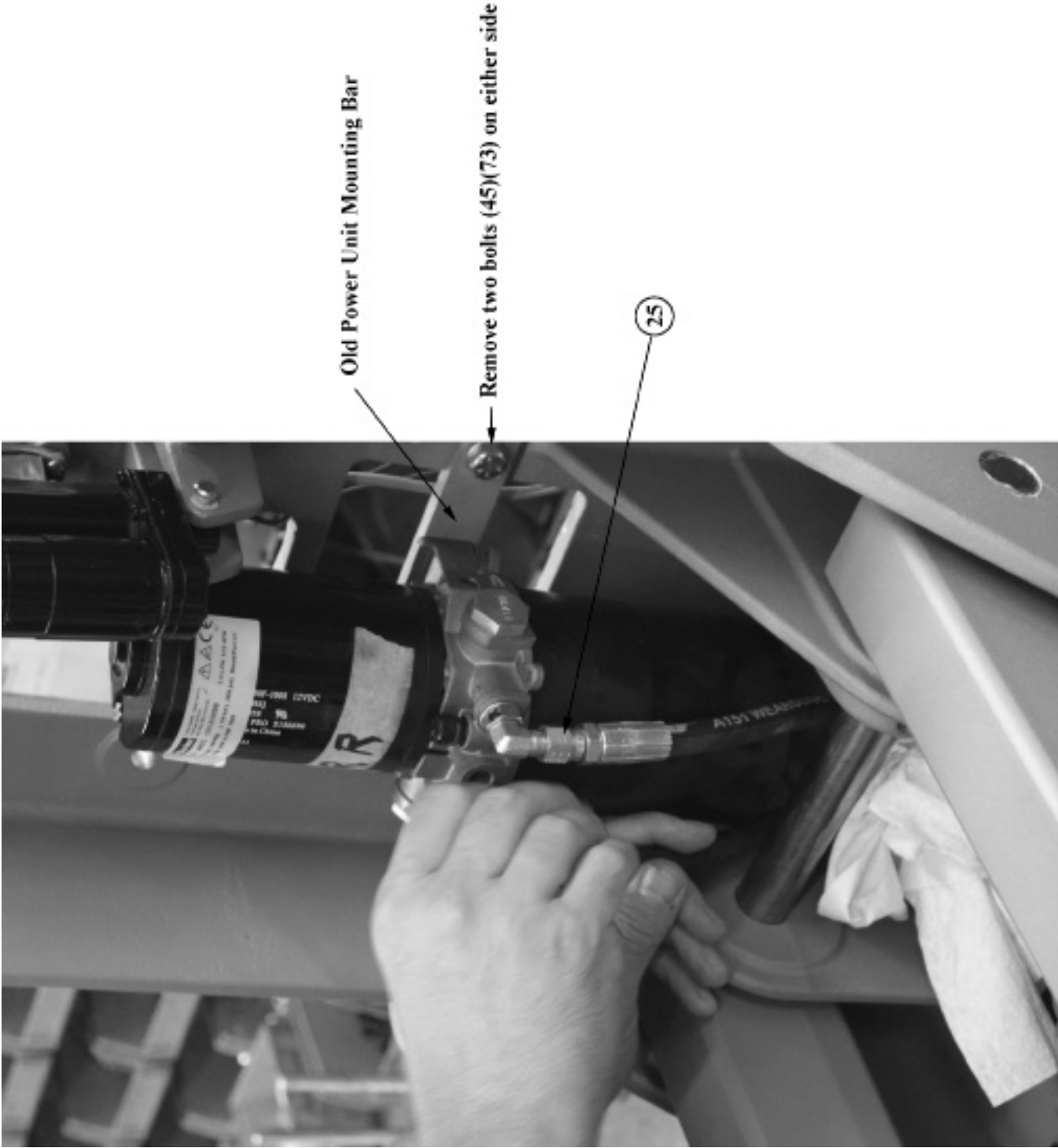


FIGURE 101

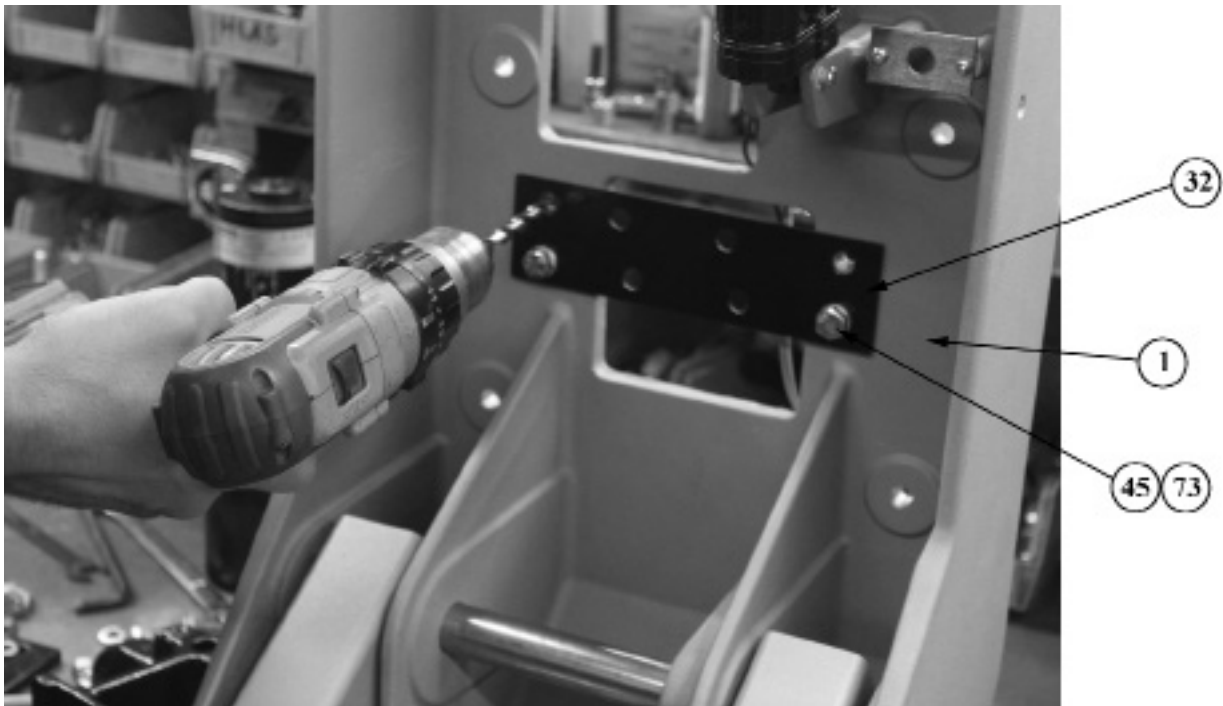
### III. Preparation for the New Hydraulic Power Unit

**Note:** Figures 102A and 102B show the top two holes being drilled and tapped into the Base Casting (1) for the Power Unit Mounting Bar (32). If the top two holes already exist, skip to section IV.

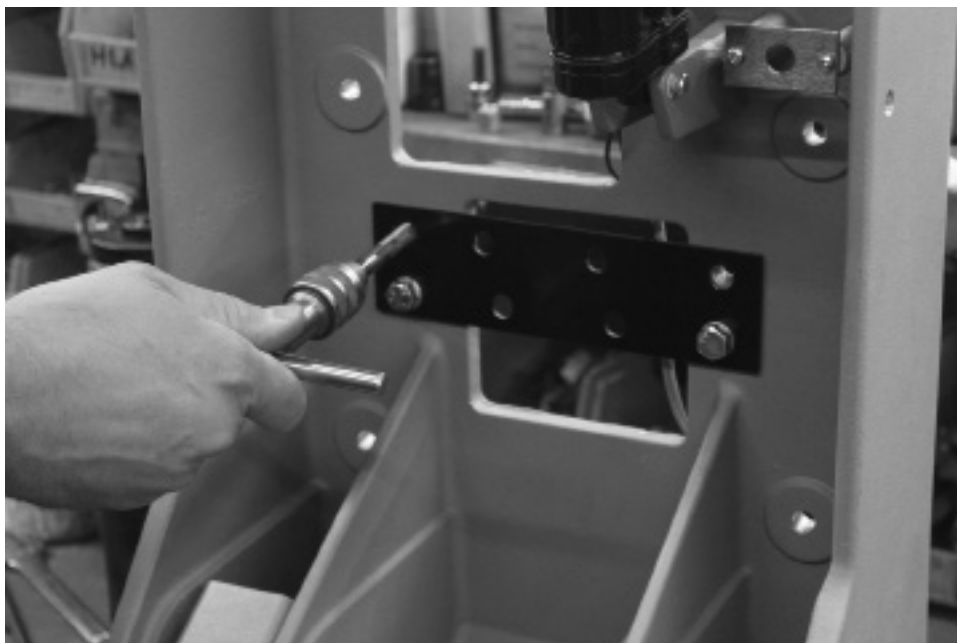
**IMPORTANT:** If the existing Base Casting (1) does not have four holes in it to receive the new Power Unit Mounting Bar (32), the casting must be drilled and tapped as shown in Figures 102A and 102B. **DO NOT ATTEMPT TO RUN THE UNIT WITH THE PLATE MOUNTED TO THE CASTING WITH ONLY TWO BOLTS.**

1. Bolt the new Power Unit Mounting Bar (32) onto the Base Casting (1) using two 3/8-16 x 3/4" hex head bolts (45) and two 3/8" lock washers (73). See Figure 102A, page 5.
2. Drill and Tap for a 3/8"-16 thread. See Figures 102A and 102B, page 5.
3. Remove the Power Unit Mounting Bar (32) from the Base Casting (1). This will be reattached at a later time.

**FIGURE  
102A**

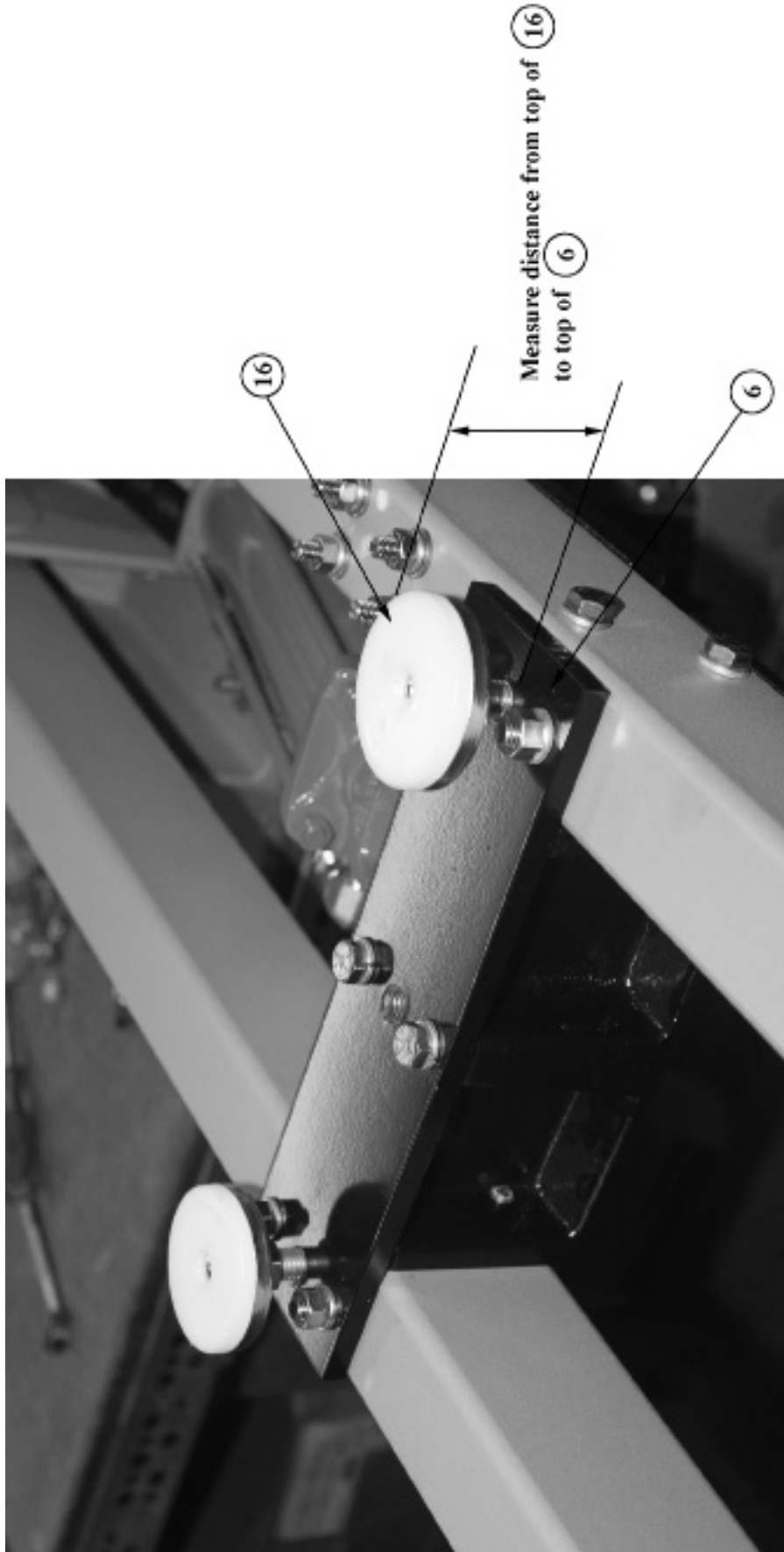


**FIGURE 102B**



#### **IV. Removal of Old Hydraulic Cylinder**

1. Measure and record the distance from the top of the Mechanical Bumper Stops (16) to the Upper Mounting Block Backing Plate (6). See Figure 103A, page 7.
2. Remove the Mechanical Bumper Stops (16) in Figure 103A, page 7.
3. Remove the Upper Mounting Block Backing Plate (6) from the LH and RH boom arms (2 & 3). See Figure 103B, page 8.
4. Lift the LH and RH boom arms (2 & 3) and bungee cord them in an upward position.
5. Remove the Cotter Pin (60) and the Upper 1" Dia. Cylinder Pin (56) from the Upper Mounting Block Casting (5). See Figure 104, page 8.
6. Remove the Cotter Pin (60) and the Lower 1" Dia. Cylinder Pin (57) from the Base Casting (1) and the Hydraulic Cylinder. (Note that the lower pin has a Spin Drive Grease Fitting (33) in it.) See Figure 104, page 8.



**FIGURE 103A**



FIGURE 103B

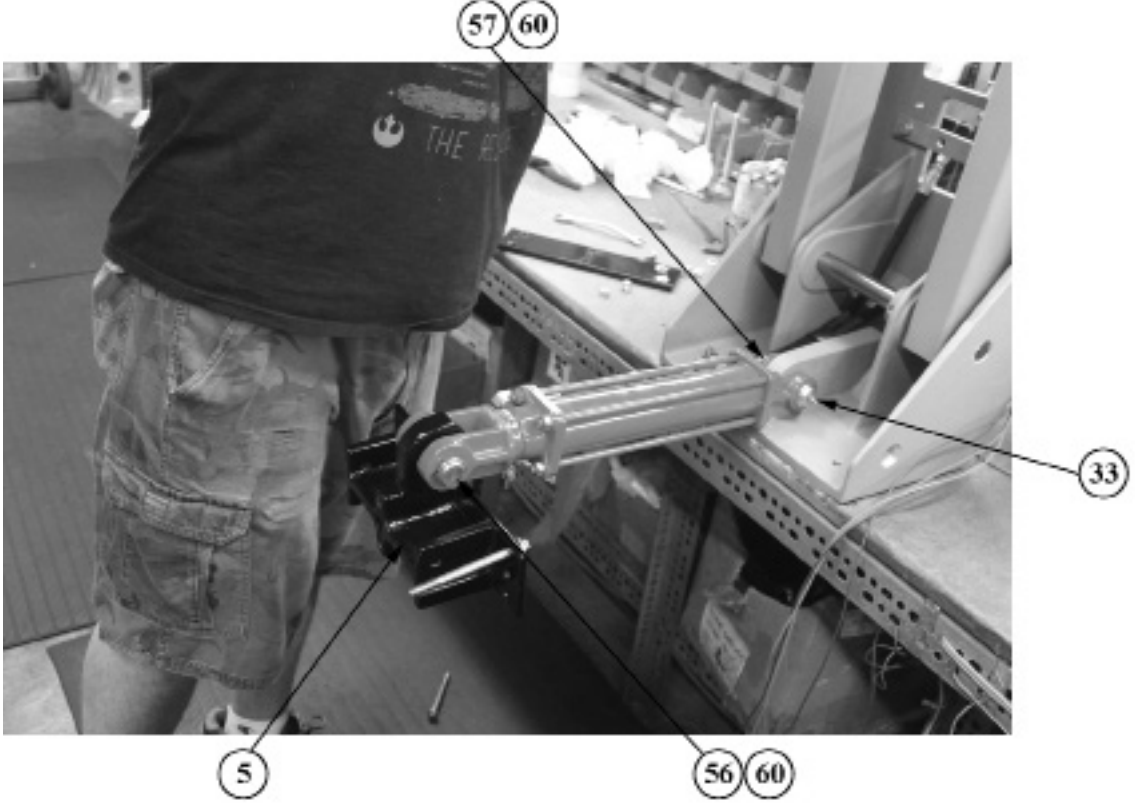


FIGURE 104

## V. Installation of New Hydraulic Power Unit (Pump and Motor)

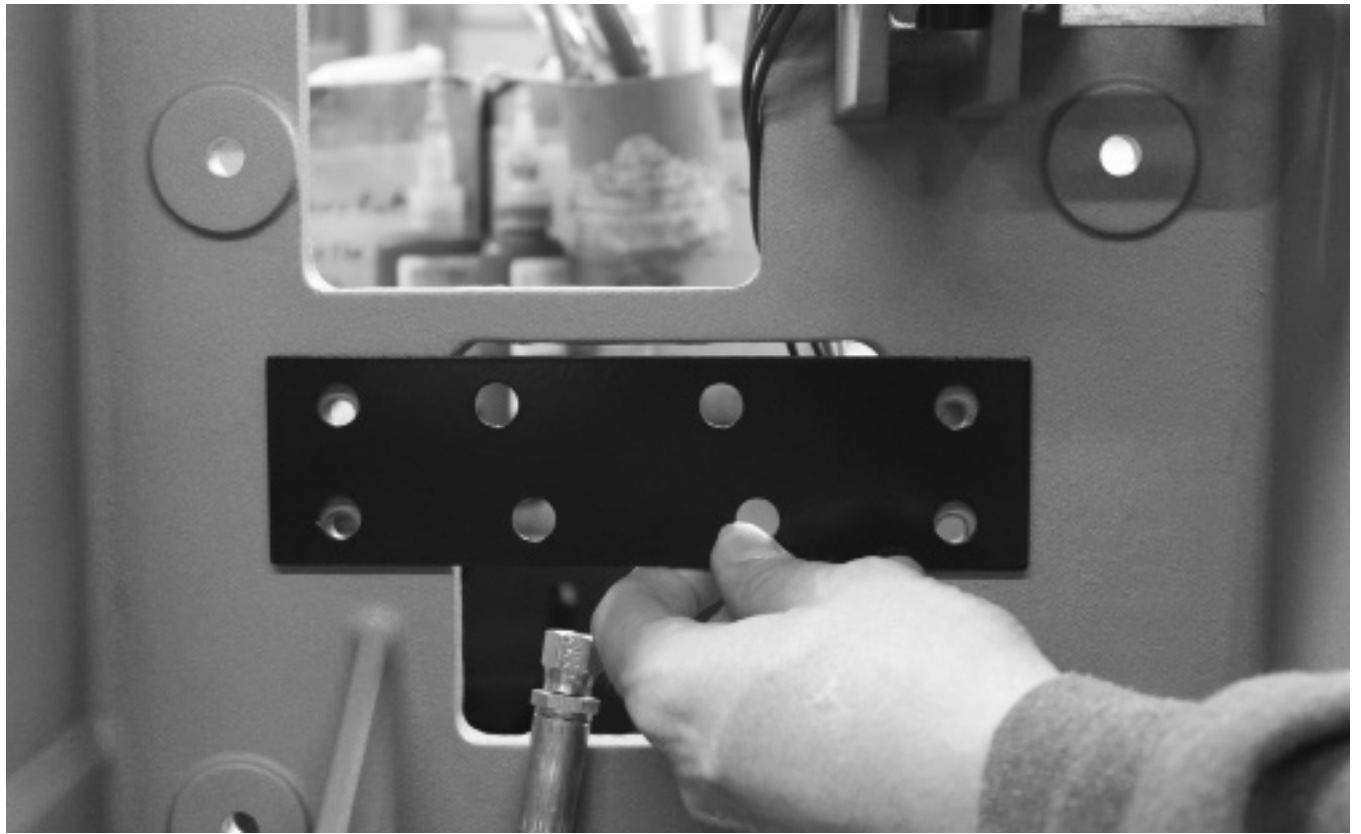
**Note:** See Figures 105A and 105B, page 10, for specific bolt locations which are essential for proper reassembly. Figure 105A shows the plate to the Base Casting. Figure 105B shows the plate mounted to the power unit.

1. Fasten the Hydraulic Power Unit (7) to the Power Unit Mounting Bar (32). See Figures 105A and 105B, page 10, for specific mounting holes.
2. Fasten the Power Unit Mounting Bar (32) to the Base Casting (1) using four bolts (45) and four lock washers (73). See Figure 106B, page 12.
3. Electrical Hook-Up:
  - a. Cut off the old hydraulic power unit's supply line electrical connectors that are run from the vehicle.
  - b. Slide the Red Electrical Boots (51) onto the wires then splice & crimp on the two 5/16" Yellow Ring Terminals that are supplied with the wires. See Figure 106A, page 11.
  - c. Connect the red wire to the new Hydraulic Power Unit (7) terminal 2. See Figure 106B, page 12.
  - d. Connect the yellow wire to the new Hydraulic Power Unit (7) terminal 1. See Figure 106B, page 12.

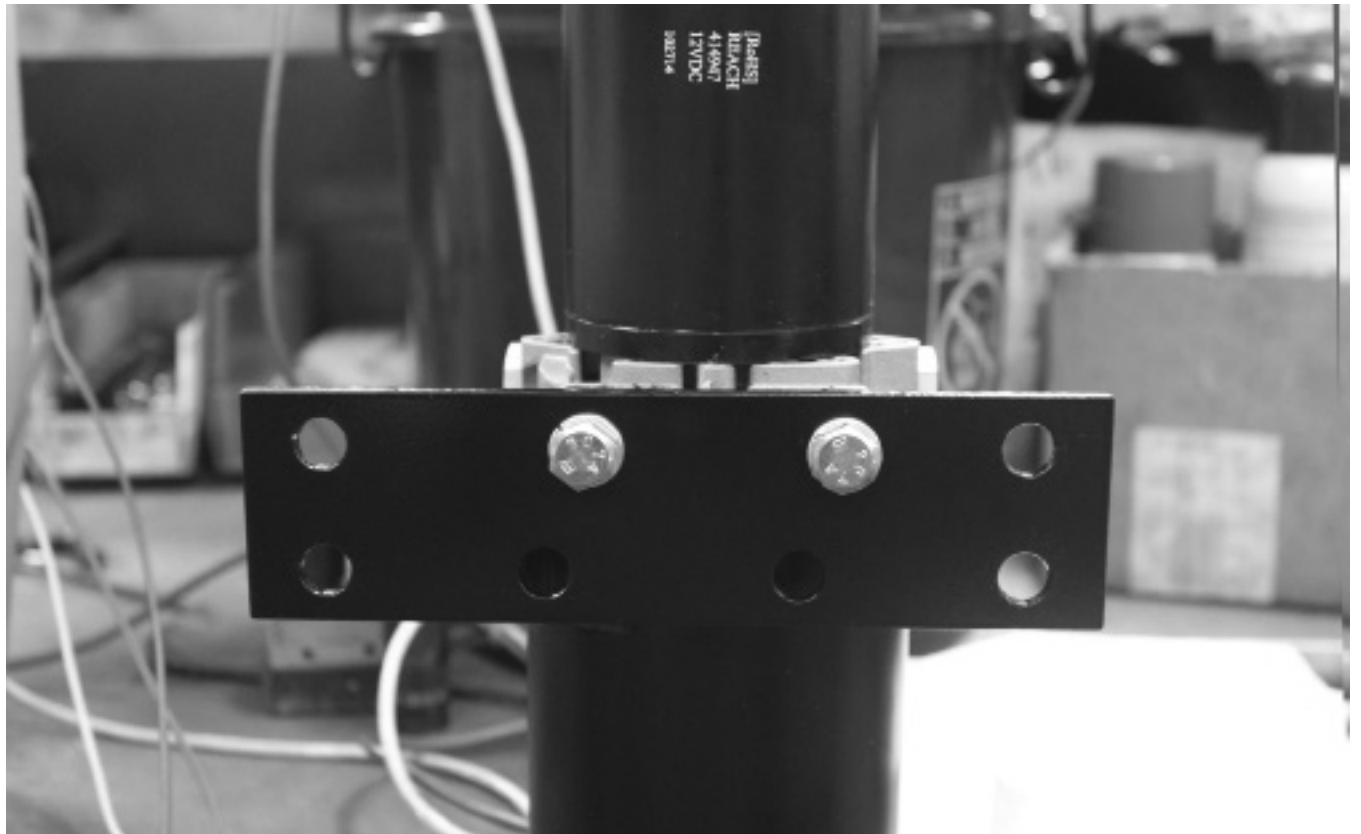
**IMPORTANT:** DO NOT attempt to run system before hydraulic fluid is added. Fluid will be added later in the installation process.

4. Attach the hydraulic lines to the elbow fittings (25) on the front side of the pump. See Figure 106B, page 12.

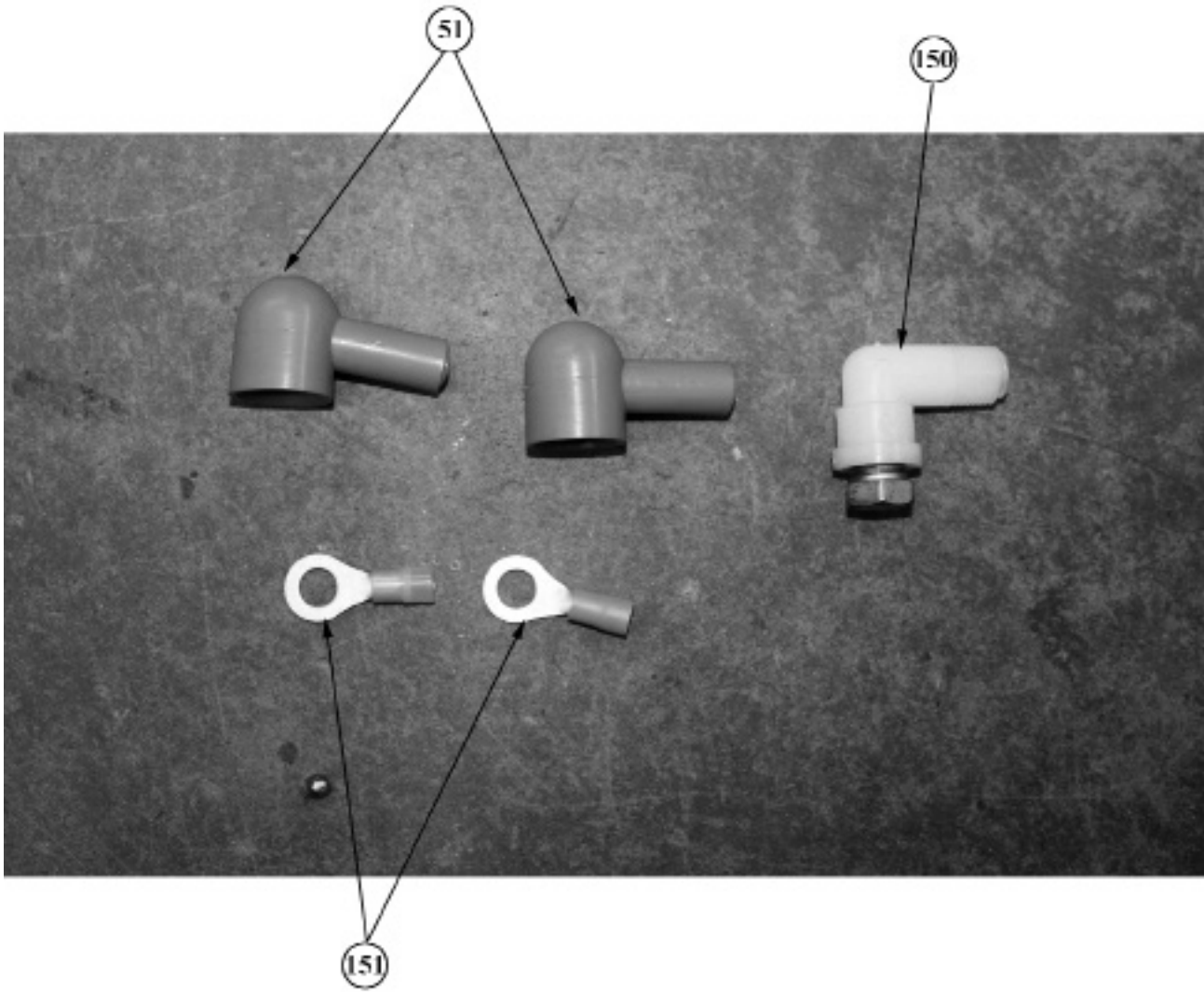




**FIGURE 105A**



**FIGURE 105B**



**FIGURE 106A**

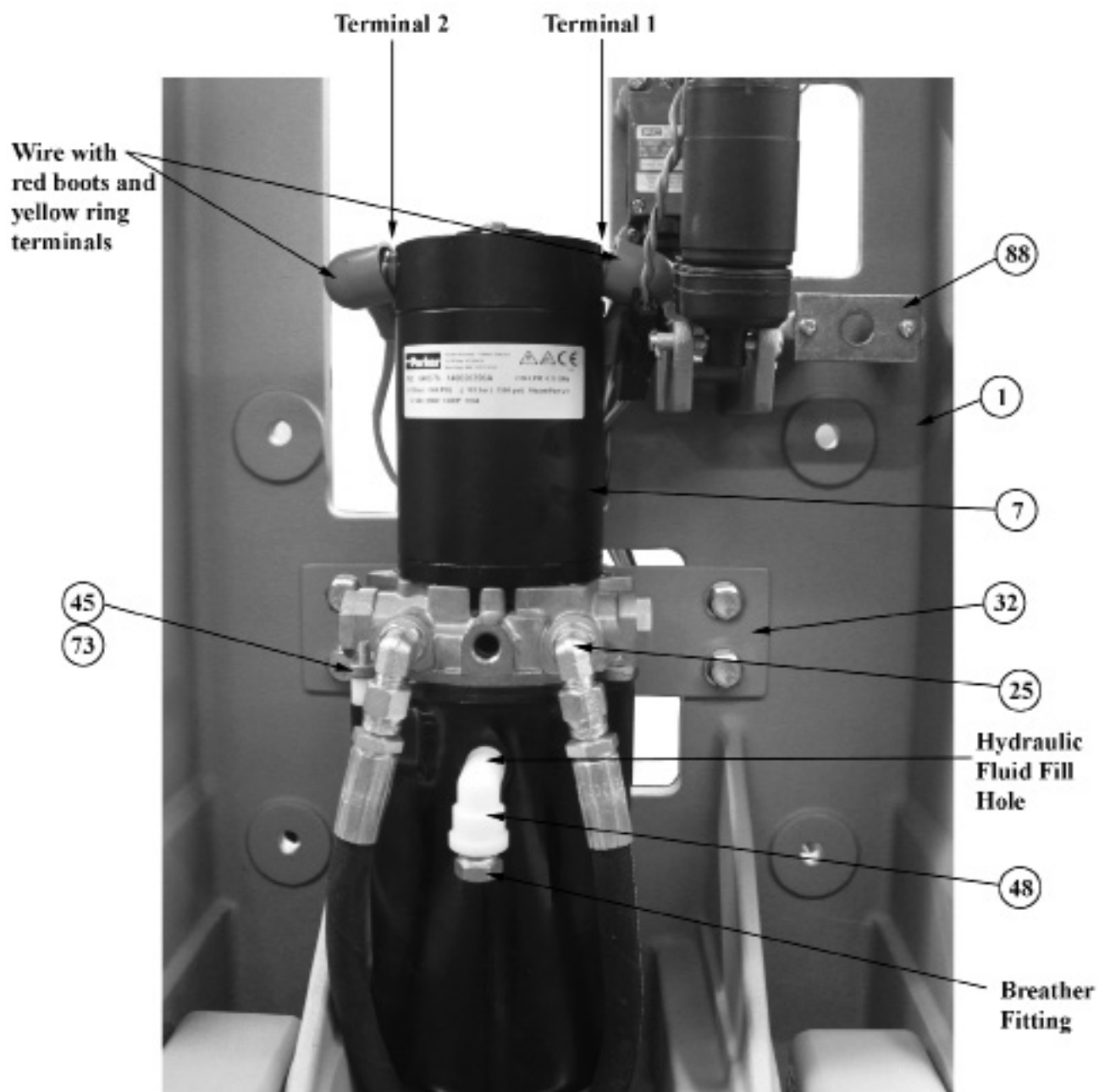
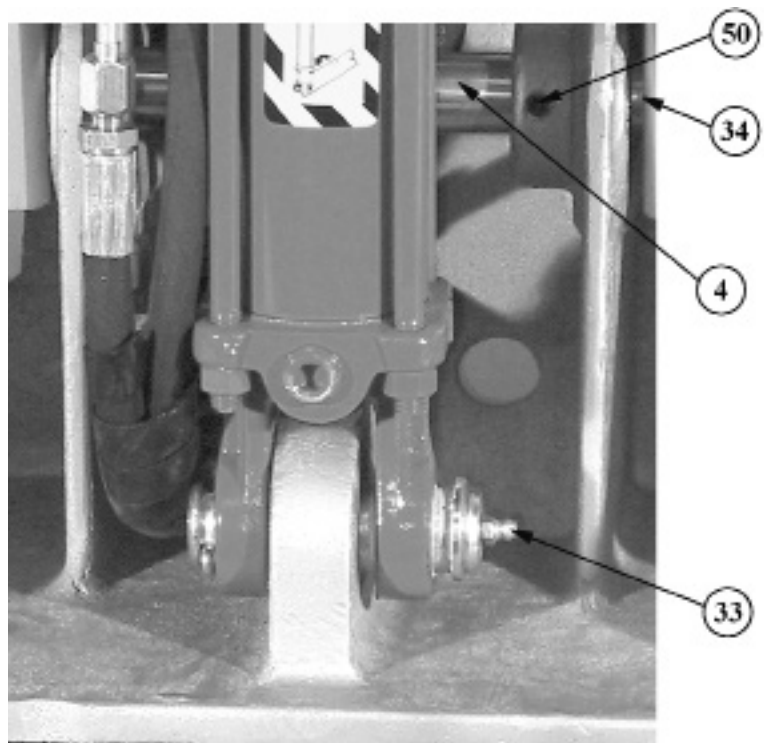


FIGURE 106B

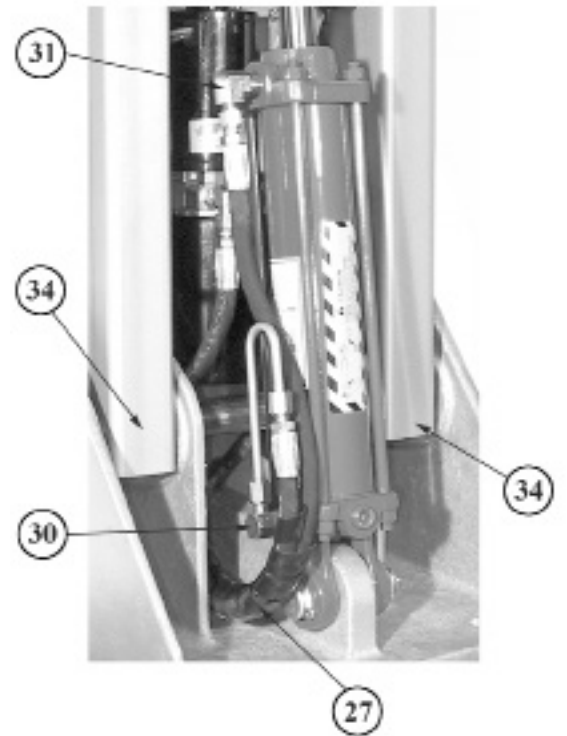
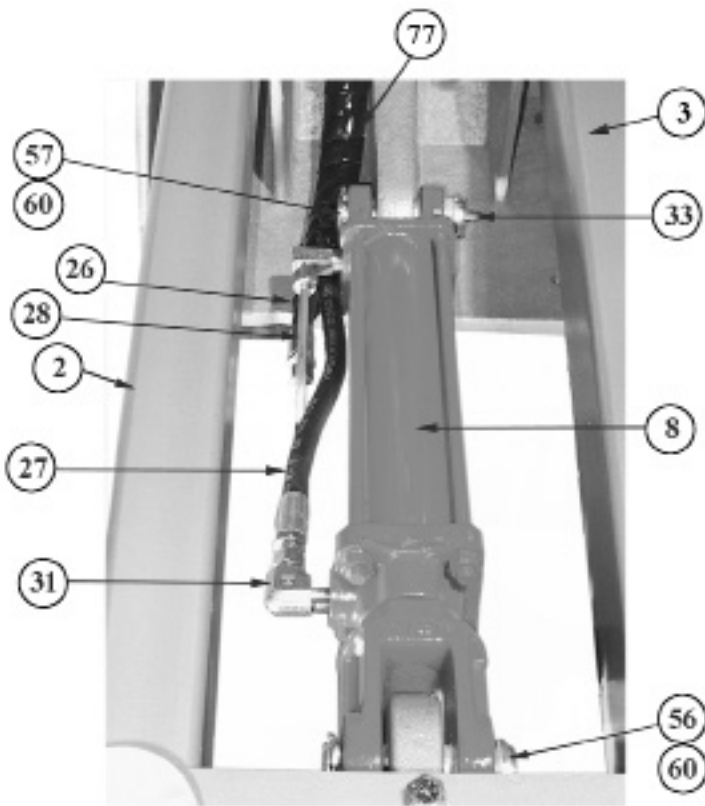
## **VI. Installation of New Hydraulic Cylinder**

1. Attach to the Base Casting (1) the new Hydraulic Cylinder (8) with the Lower 1" Dia. Cylinder Pin (57) and new Cotter Pin (60). (Note that the lower pin has a Spin Drive Grease Fitting (33) in it.) See Figure 104, page 8.
2. Attach the new Hydraulic Cylinder (8) to the Upper Mounting Block Casting (5) with the Upper 1" Dia. Cylinder Pin (56) and new Cotter Pin (60). See Figure 104, page 8.
3. Loosely connect the Hydraulic Lines to the Hydraulic Cylinder (8) Fitting (31). The system must be able to breathe before hydraulic fluid is added for manual boom movement. See Figure 21, page 14.
4. Raise the Upper Mounting Block Casting (5) so that holes align with the holes in the boom arms. Install Bolts (47) and Washers (68) only to temporarily attach the Upper Mounting Block Casting (5) to the boom arms. See Figures 107A and 107B, page 15.
5. Remove the bungee cords and lower the booms.
6. Mount the Upper Mounting Block Backing Plate (6) by adding the hardware shown in Figures 108A and 108B, page 16. Tighten all nuts and bolts.
7. Install the Mechanical Bumper Stops (16) at the distance recorded in Section IV, Step 1 but DO NOT tighten yet. See Figure 103A, page 7.

Refer to the instruction manual 3097PM6, section VI "Troubleshooting" on page 16 for cylinder ram adjustment. Keep in mind that the HPTS rack is mounted in that situation. Disregard that information when making the cylinder ram adjustment.



**FIGURE 21**  
**HYDRAULIC COMPONENTS WITH HYDRAULIC CYLINDER**



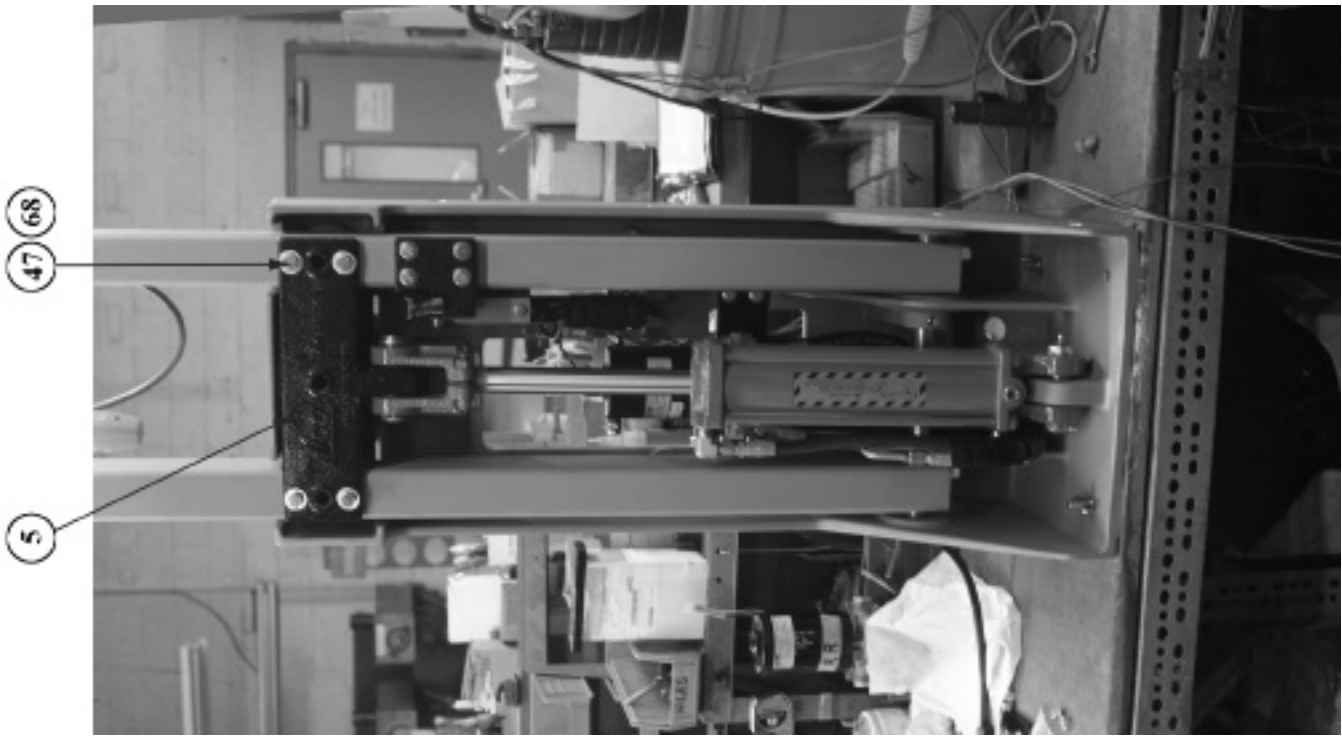


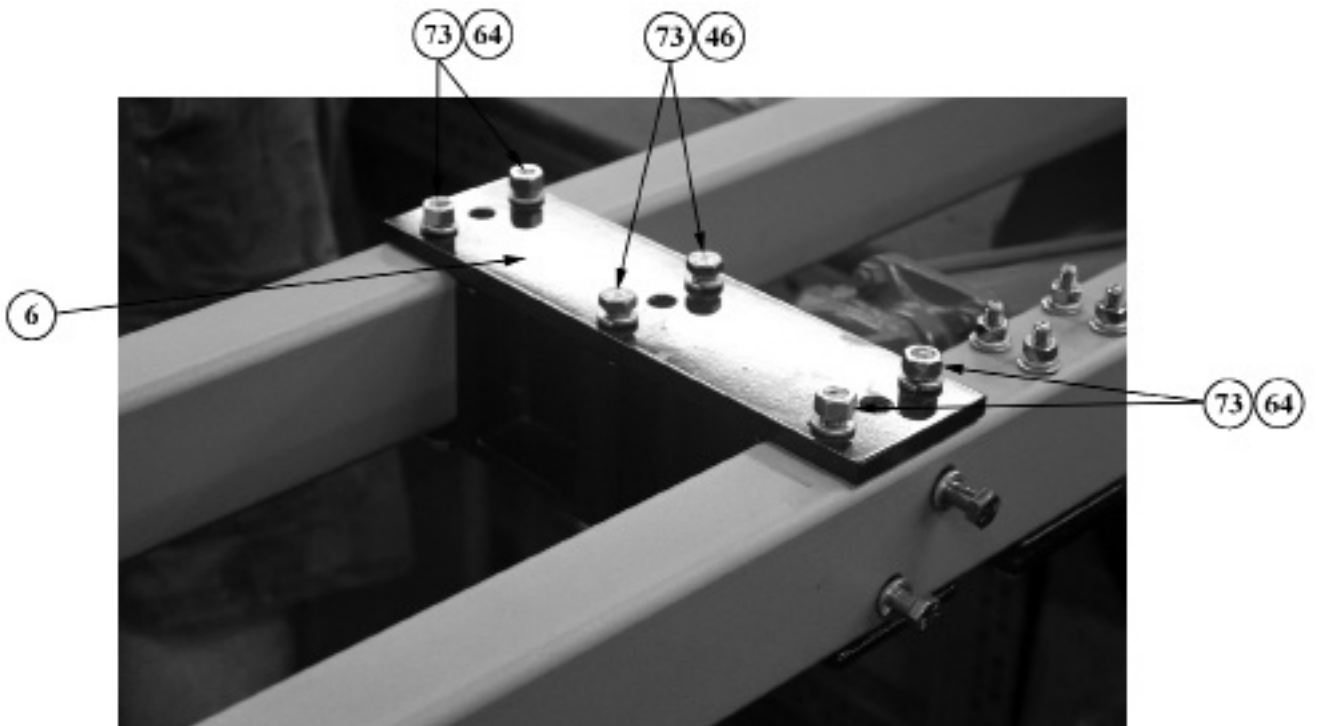
FIGURE 107B



FIGURE 107A



**FIGURE 108A**



**FIGURE 108B**

## VII. Adding Hydraulic Fluid

1. Put 32 ounces of fresh hydraulic fluid into the pump through the breather/fill hole where Plastic Breather Elbow (48) is normally located.
2. Manually Run the booms up and down three to four times. Bleed air from the lines the first time. Wait approximately 5 minutes with the booms down, check the fluid level. Approximately 18 ounces of fluid will have been moved into the lines and hydraulic cylinder.
3. Add approximately 14 ounces of fluid to the reservoir, cycle the system a few more times and then recheck fluid level. 1/4" to 1/2" below breather/fill hole is a good level.
4. A couple more ounces of fluid may have to be added to bring the fluid up. When the full level is obtained, install breather elbow (48) with the breather. Fluid and power unit replacement are complete.

***IMPORTANT:*** Make sure all hydraulic lines are tight and check for leaks.

## VIII. Reinstallation of the HPTS Rack (if applicable)

1. See 3097PM6 Figure 20 on page 24.

Troubleshooting: If the system is running incorrectly, reverse the two wires connected to the Hydraulic Power Unit (7).



*Ziamatic Corp.*

10 West College Avenue, P.O. Box 337, Yardley, PA 19067-0587 • (215) 493-3618 • FAX: (215) 493-1401

\*ZICO is a registered trademark for fire, safety and marine products made by Ziamatic Corp.

[www.ziamatic.com](http://www.ziamatic.com)

TOLL FREE: 800-711-3473

Copyright Ziamatic Corp. 11-16