

MULTIPLE EXTRICATION TOOL HOLDERS MODELS QM-MEH-1 & QM-MEH-_-R PARTS AND INFORMATION MANUAL

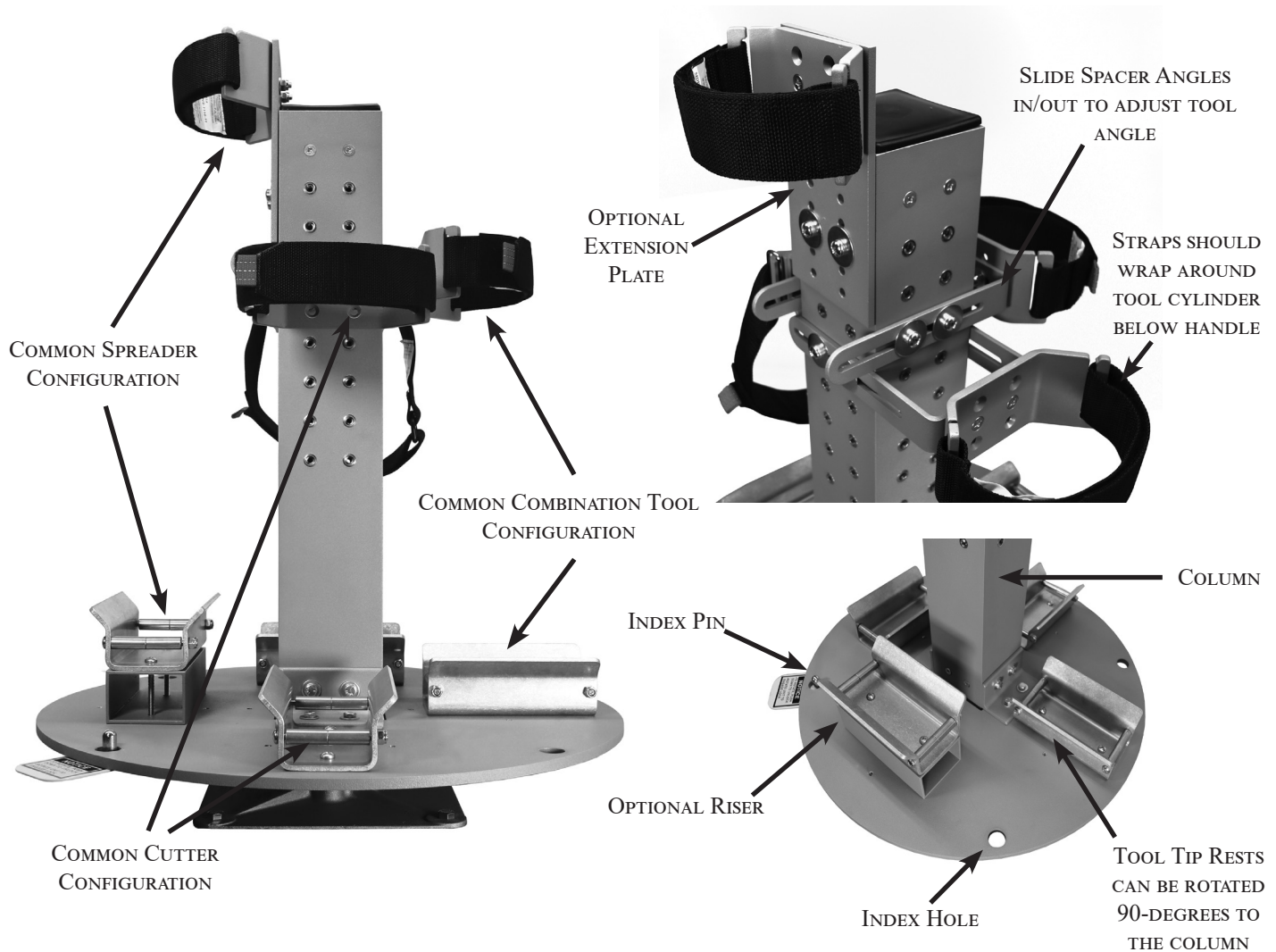

I. MODELS AVAILABLE

QM-MEH-1: Multiple Extrication Tool Holder

QM-MEH-1-R: Multiple Extrication Tool Holder with One Ram Mount

QM-MEH-2-R: Multiple Extrication Tool Holder with Two Ram Mounts

QM-MEH: Multiple Extrication Tool Holder Less Brackets

II. APPARATUS INSTALLATION

Using holes in the Base Casting (1) as a guide, mount Base Casting to compartment shelf or slide-out tray using 3/8" diameter, Type 4X hardware (not provided). Reinforcement of mounting surface may be required to support the combined weight of the unit and tools.

III. BASE ASSEMBLY

1. Loosely attach the angled Base Plate Brackets (17) to opposite sides of the square holes in the Tool Base Plate (16) using fasteners provided (29, 31, 44). Set Tool Base Plate aside.
2. On each side of the Column (7), towards the bottom, locate and remove the two pairs of Hex Head screws (30) and Lock Washers (28). Four screws total.
3. Slide the Tool Base Plate over the Column so that the holes in the Base Plate Brackets align with the now empty holes at the bottom of the Column. Attach Tool Base Plate Brackets to Column using fasteners from Step 2 above. Tighten.

IV. OPERATION

The Multiple Extrication Tool Holder is designed to lock into four, 90-degree positions.

To rotate, press down on the Spring Lock Bar (39) and rotate the tools in either direction until reaching the tool you wish to access. Release the Spring Lock Bar and the Index Pin (40) will lock into the nearest Index Hole to secure the unit.

COLUMN AND BASE SUB ASSEMBLY

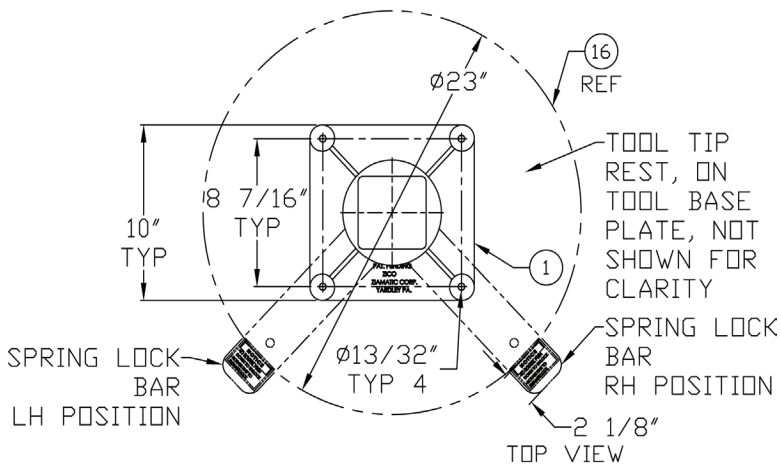

SPACERS ANGLES CAN BE OVERLAPPED TO SHARE MOUNTING HOLES

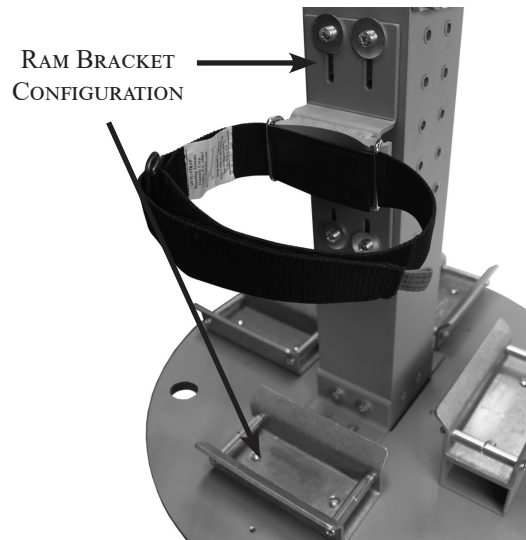
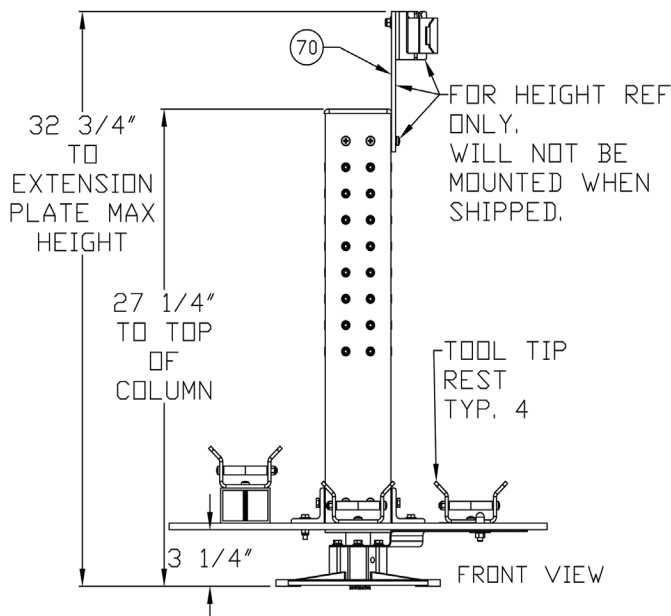

ITEM	PART NO.	DESCRIPTION	QTY.
1	3095-260-151	BASE CASTING	1
2	3095-260-101	POST 1-1/4" DIA	1
3	3095-260-103	2" O.D. x 1 9/32" I.D. x 1/2" NYLON SPACER	1
5	3095-260-163	INNER BEARING ASSY	2
7	3095-260-111	COLUMN	1
10	1035-105-150	COLLAR	2
11	1035-105-155	CAP/PLUG	1
14	9040-103132	SPRING PIN, 5/16" x 2" LG.	1
16	3095-260-121	TOOL BASE PLATE	1
17	3095-260-123	BASE PLATE BRACKET	2
25	9010-162510	SCREW, 1/4-20 x 5/8" 100*FHPS, ZPS	12
26	9012-272500	NUT INSERT, 1/4-20	64
28	9012-202500	LOCK WASHER, 1/4"	18
29	9014-202500	FLAT WASHER, 1/4"	18
30	9010-102516	SCREW, 1/4-20 x 1" HEX HD ZPS	8
31	9015-172500	NYLOCK NUT, 1/4-20 FR5 ZPS	22
32	9014-162500	WASHER, 1/4" x 1-1/4" FENDER	8
38	0000-000-149	BLANK MODEL TAG W/PAT PEND.	1
39	3095-260-153	SPRING LOCK BAR	1
40	3095-260-155	INDEX PIN	1
41	9014-163100	WASHER, 5/16" x 1-1/4", ZPS	1
42	9015-113100	NUT, 5/16"-18 HEX, GR5, ZPS	1
43	3095-260-157	LABEL ON SPRING LOCK BAR	1

ITEM	PART NO.	DESCRIPTION	QTY
44	9015-102520	SCREW, 1/4-20 x 1-1/4", HEX HD	4
45	3095-260-159	SPACER TUBE	1
46	9014-203100	LOCK WASHER, 5/16", ZPS	1
61	3095-260-143	RISER, TOOL TIP REST	1
62	3095-260-145	TOOL TIP REST	4
63	3095-260-147	SPACERS, 1/4" x 1/2" x 1-5/16"	16
64	9010-222556	SCREW, 1/4-20 x 3-1/2", PAN PH	8
65	9010-222540	SCREW, 1/4-20 x 2-1/2", PAN PH	2
66	9010-222508	SCREW, 1/4-20 x 1/2", PAN PH	6
68	9010-162516	SCREW, 1/4-20 x 1", FH PH	10
69	9010-222516	SCREW, 1/4-20 x 1", PAN PH	10
70	3095-260-139	EXTENSION PLATE	1
71	3095-260-141	SPACER ANGLE	8
72	3095-260-131	BRACKET, QUICK GRIP STRAP	4
73	3099-736-000	STRAP, UMVS-1116-11	4
74	3099-734-000	STRAP, UMVS-0811-11	1
75	0000-000-121	THREAD LOCK, MEDIUM	

MODEL QM-MEH-1

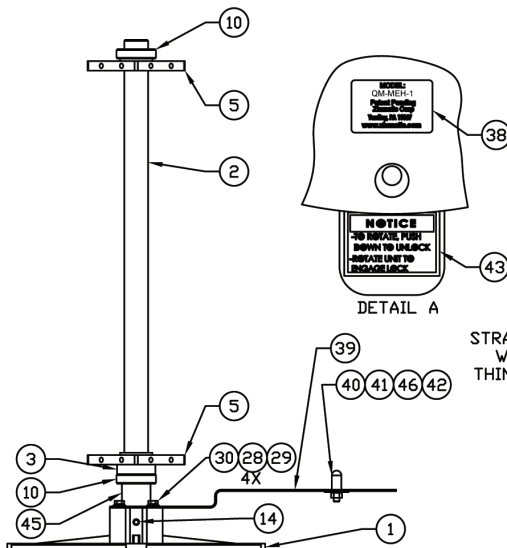

ADDITIONAL SHORTER STRAP SUPPLIED, TO BE USED WITH TOOLS THAT HAVE THINNER CYLINDERS SUCH AS COMBINATION TOOLS.

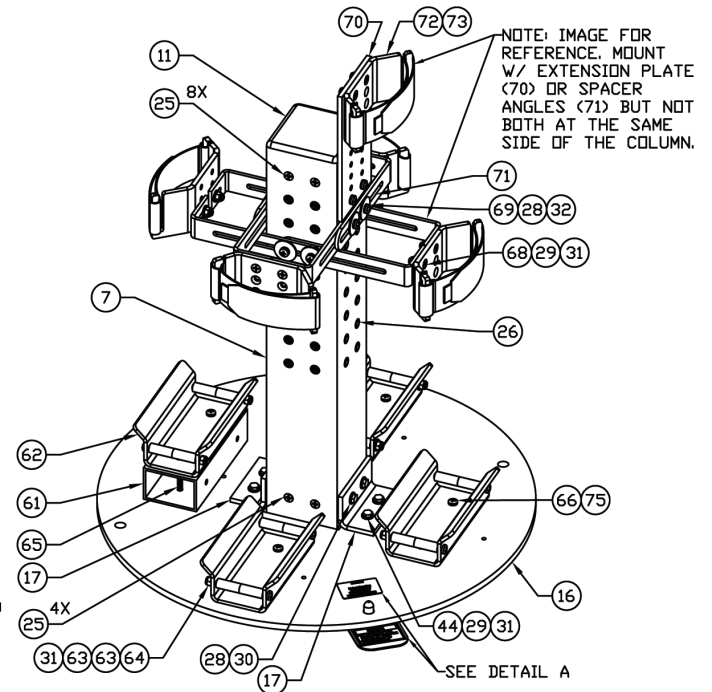

ITEM	PART NO.	DESCRIPTION	QTY.
1	3095-260-151	BASE CASTING	1
2	3095-260-101	POST, 1-1/4" DIA.	1
3	3095-260-113	2" O.D. x 1-9/32" I.D. x 1/2" NYLON SPACER	1
5	3095-260-163	INNER BEARING ASSY	2
7	3095-260-111	COLUMN	1
10	1035-105-150	COLLAR	2
11	1035-105-155	CAP/PLUG	1
14	9040-103132	SPRING PIN, 5/16" x 2" LG.	1
16	3095-260-121	TOOL BASE PLATE	1
17	3095-260-123	BASE PLATE BRACKET	2
25	9010-162510	SCREW, 1/4-20 x 5/8" 100*FHPS, ZPS	12
26	9012-272500	NUT INSERT, 1/4-20	64
28	9012-202500	LOCK WASHER, 1/4"	22
29	9014-202500	FLAT WASHER, 1/4"	18
30	9010-102516	SCREW, 1/4-20 x 1" HEX HD ZPS	8
31	9015-172500	NYLOCK NUT, 1/4-20 FR5 ZPS	20
32	9014-162500	WASHER, 1/4" x 1-1/4" FENDER	12
38	0000-000-149	BLANK MODEL TAG W/PAT PEND.	1
39	3095-260-153	SPRING LOCK BAR	1
40	3095-260-155	INDEX PIN	1
41	9014-163100	WASHER, 5/16" x 1-1/4", ZPS	1
42	9015-113100	NUT, 5/16-18 HEX, GR5, ZPS	1
43	3095-260-157	LABEL ON SPRING LOCK BAR	1

ITEM	PART NO.	DESCRIPTION	QTY
44	9015-102520	SCREW, 1/4-20 x 1-1/4", HEX HD	4
45	3095-260-159	SPACER TUBE	1
46	9014-203100	LOCK WASHER, 5/16", ZPS	1
50	3095-265-901	HANGING ARM ASSY	1
51	3099-247-105	7" BASE STRAP, CYBS-2123-70-11	1
52	3099-000-006	"D" RING, NICKEL PLATE, 2" LOOP	2
61	3095-260-143	RISER, TOOL TIP REST	1
62	3095-260-145	TOOL TIP REST	4
63	3095-260-147	SPACERS, 1/4" x 1/2" x 1 5/16"	16
64	9010-222556	SCREW, 1/4-20 x 3-1/2", PAN PH	8
65	9010-222540	SCREW, 1/4-20 x 2-1/2", PAN PH	2
66	9010-222508	SCREW, 1/4-20 x 1/2", PAN PH	6
68	9010-162516	SCREW, 1/4-20 x 1", FH PH	8
69	9010-222516	SCREW, 1/4-20 x 1", PAN PH	14
70	3095-260-139	EXTENSION PLATE	1
71	3095-260-141	SPACER ANGLE	6
72	3095-260-131	BRACKET, QUICK GRIP STRAP	3
73	3099-736-000	STRAP, UMVS-1116-11	3
74	3099-734-000	STRAP, UMVS-0811-11	1
75	0000-000-121	THREAD LOCK, MEDIUM	

MODEL QM-MEH-1-R

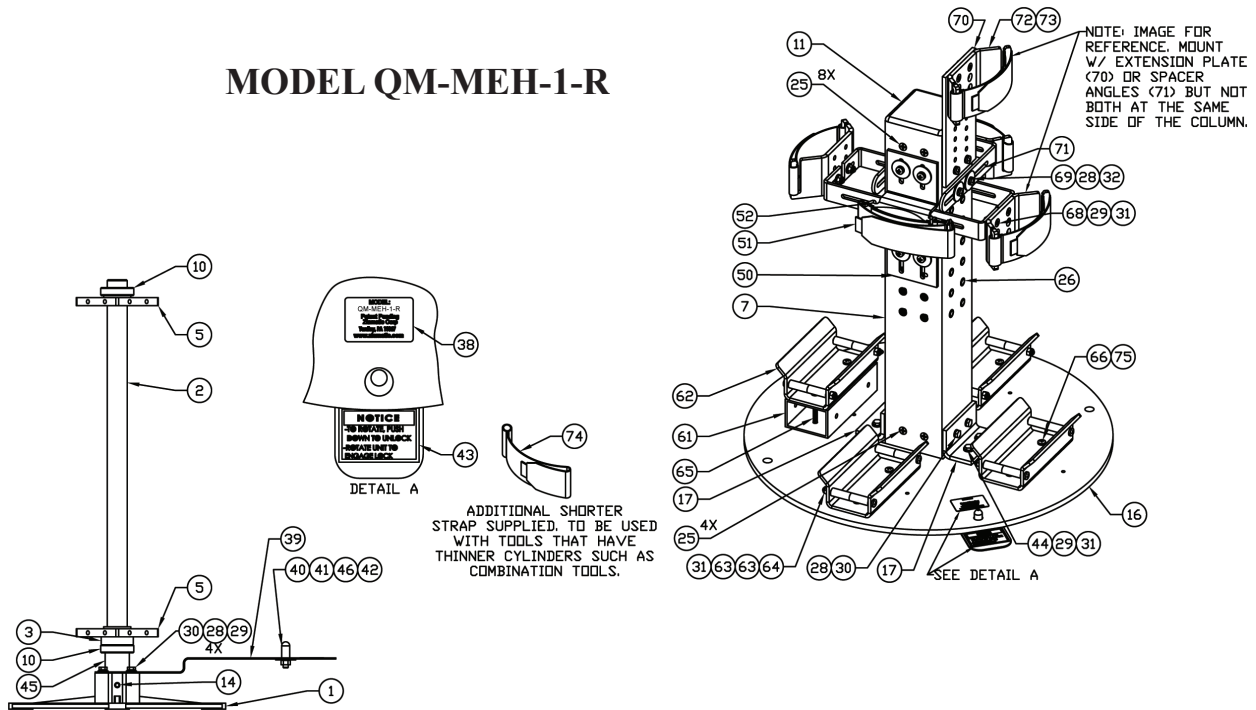

Ziamatic Corp.

10 West College Avenue, P.O. Box 337, Yardley, PA 19067-0587 • (215) 493-3618 • FAX: (215) 493-1401

*ZICO is a registered trademark for fire, safety and marine products made by Ziamatic Corp.

Copyright Ziamatic Corp. 3-21