

**LADDER GANTRY SYSTEM
MODEL SLG-M
PARTS AND INSTRUCTION MANUAL**

- Secures most common ladder combinations horizontally over the top of the apparatus
- Extends from the rear of the apparatus and tilts down to a convenient angle for safe and easy ladder retrieval
- Maximum load not to exceed 300 lbs.

MODEL	DESCRIPTION	WT. /@ IN LBS.
SLG-M-8	Ladder Gantry System for 8' H Shelf - Complete Unit	248.0
SLG-M-10	Ladder Gantry System for 10' H Shelf - Complete Unit	248.0

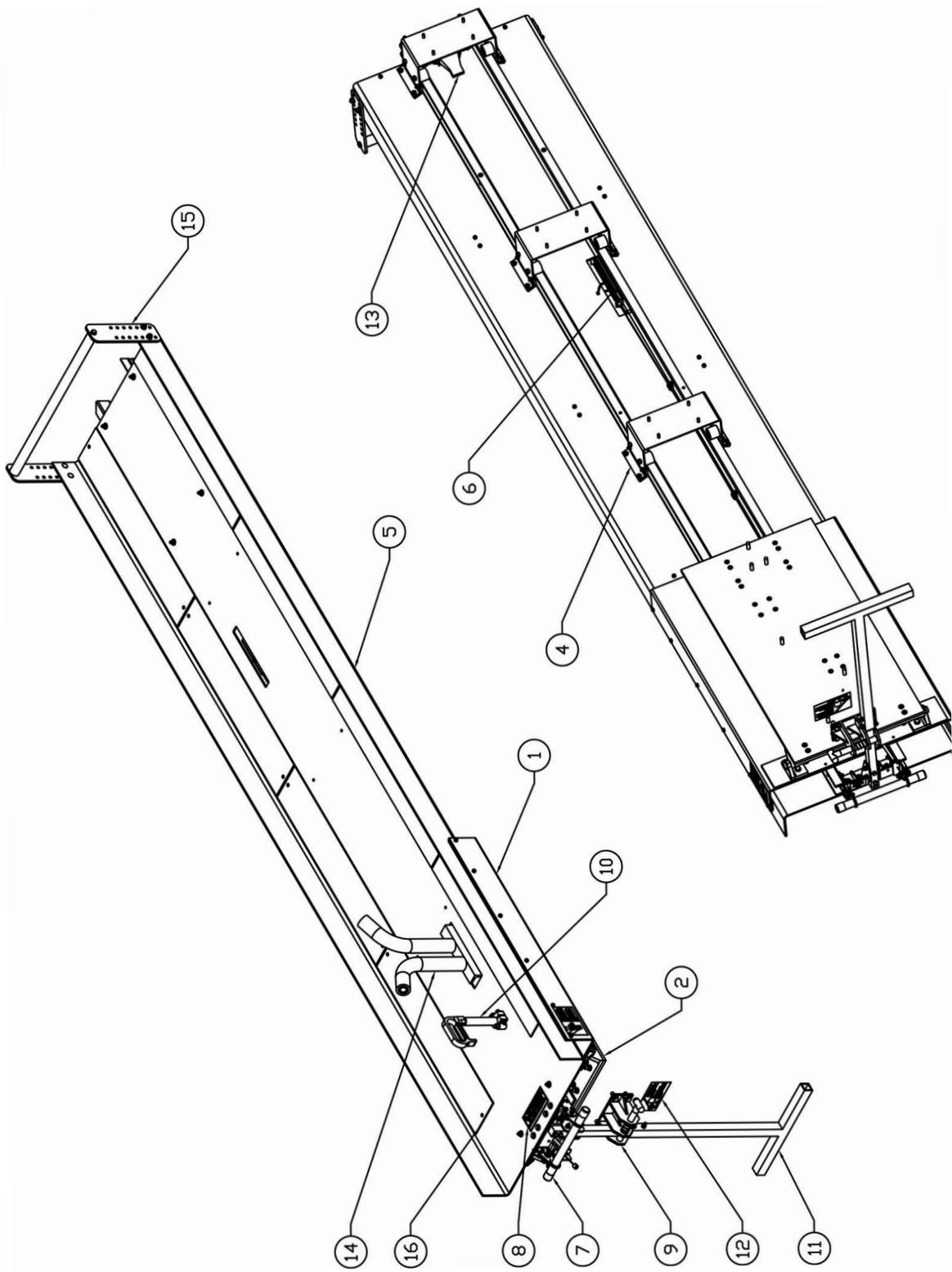

Figure 1 Base and Ladder Rack Assemblies

Figure 1 Base and Ladder Rack Assemblies

ITEM NO.	PART NO.	DESCRIPTION	QTY.
1		BASE TOP ASSY	1
2		BASE BOTTOM ASSY	1
3		DAMPENER	1
4		RACK GUIDE-ROLLER ASSY	3
5		LADDER RACK	1
6		LOCK RELEASE/CABLE ASSY	1
7		LOCK RELEASE ASSY	1
8		HANDLE-PULL ASSY	1
9		LADDER STOP HANDLE	1
10		TRAY LOCK RELEASE ASSY	1
11		BAR-BOUNCE STOP	1
12		LADDER REST ASSY	1
13		WEAR STRIP-LADDER RACK-ASSY	8
14		CHANNEL-LADDER GUIDE	2
15		CATCH-LOWER HANDLE ASSY	1
16		FLIP HINGE 43° ASSY	1
17		REFLECTIVE TAPE	2
18		LABEL, IMPORTANT, LIFT YELLOW HANDLE	1
19		LABEL, WARNING, STRIKING INJURY	1

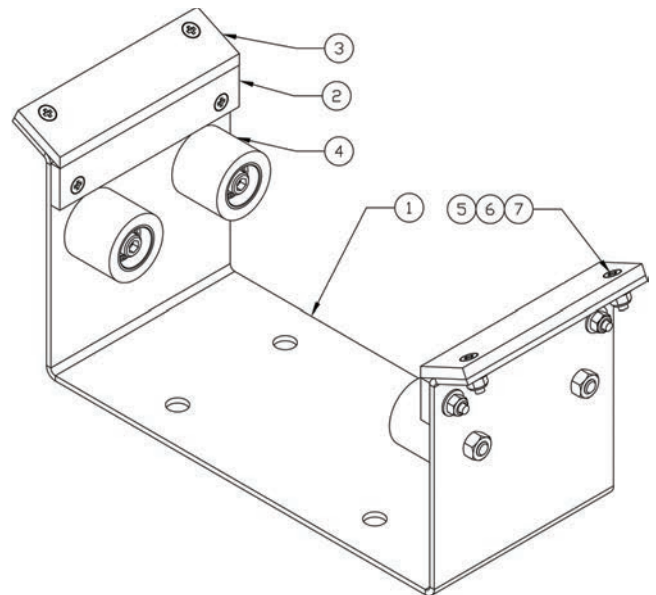

Figure 1A Rack Guide-Roller Assemblies

ITEM NO.	PART NO.	DESCRIPTION	QTY.
1		RACK GUIDE ROLLER BRACKET	1
2		RACK GUIDE WEAR STRIP, VERTICAL	2
3		RACK GUIDE WEAR STRIP, TOP	2
4		ROLLER, IDLER W/ HARDWARE	4
5		SCREW,#10-32 X 3/4, CSK HD	8
6		WASHER,#10,REGULAR	8
7		NUT, 10-32 NYLON LOCK	8

ITEM	PART NO.	DESCRIPTION	QTY.
1		PULL HANDLE PIVOTING ROD	1
2		LATCH	1
3		LATCH SLIDER	1
4		HANDLE LINKAGE-LIFTER	1
5		HANDLE LINKAGE-SPACER	1
6		HANDLE LINKAGE-PIVOT	1
7	1045-320-161	STRAP FORK AND EYE	1
8		PULL HANDLE, PIVOTING	1
9		PULL HANDLE, TELESCOPE	1
10		CABLE, PULL HANDLE	1
11		PLATE, HANDLE	2
12		LATCH RECEIVER	1
13	3097-500-160	BUMPER, RUBBER 1" H x ϕ 2 1/2"	1
14	1027-144-105	CONDUIT CLAMP	4
15	9018-221606	SCREW, #8-32 PAN HD PH	4
16		SHOULDER BOLT, ϕ 3/8 x 2", 5/16-18	1
17		SCREW, ϕ 1/4-20 x 2" HED HD	6
18		WASHER, ϕ 1/4 NARROW	10
19		NUT, ϕ 1/4-20 NYLON LOCK	11
20		WASHER, ϕ 5/16 REGULAR	1
21		WASHER, ϕ 1/4 REGULAR	10
22	1045-320-169	KNOB, PULL RELEASE	1
23	1045-320-185	STOP SLEEVE	1
24	9010-391603	SET SCREW, #8-32 x 3/19, FLAT POINT	1
25		CLEVIS PIN, ϕ 3/16 x 3/8 USABLE SS	1
26		COTTER PIN, ϕ 3/32 x .500	1
27		WASHER, ϕ 3/8 REGULAR	3
28		NUT, ϕ 5/16-18, NYLON LOCK	1
29		WASHER, #10 REGULAR	1
30		SCREW, ϕ 1/4-20 x 1 1/4 HEX	1
31		CLAMP-LOOP-VIBRATION DAMPING	2
32		SCREW, ϕ 1/4-20 x 1 3/4 HEX	1
33		SCREW, ϕ 1/4-20 x 1 5/8 HEX	1
34		PLUG, 1" SQUARE & RIBBED	2
35		SCREW, ϕ 1/4-20 x 2 1/4" HEX HD	2

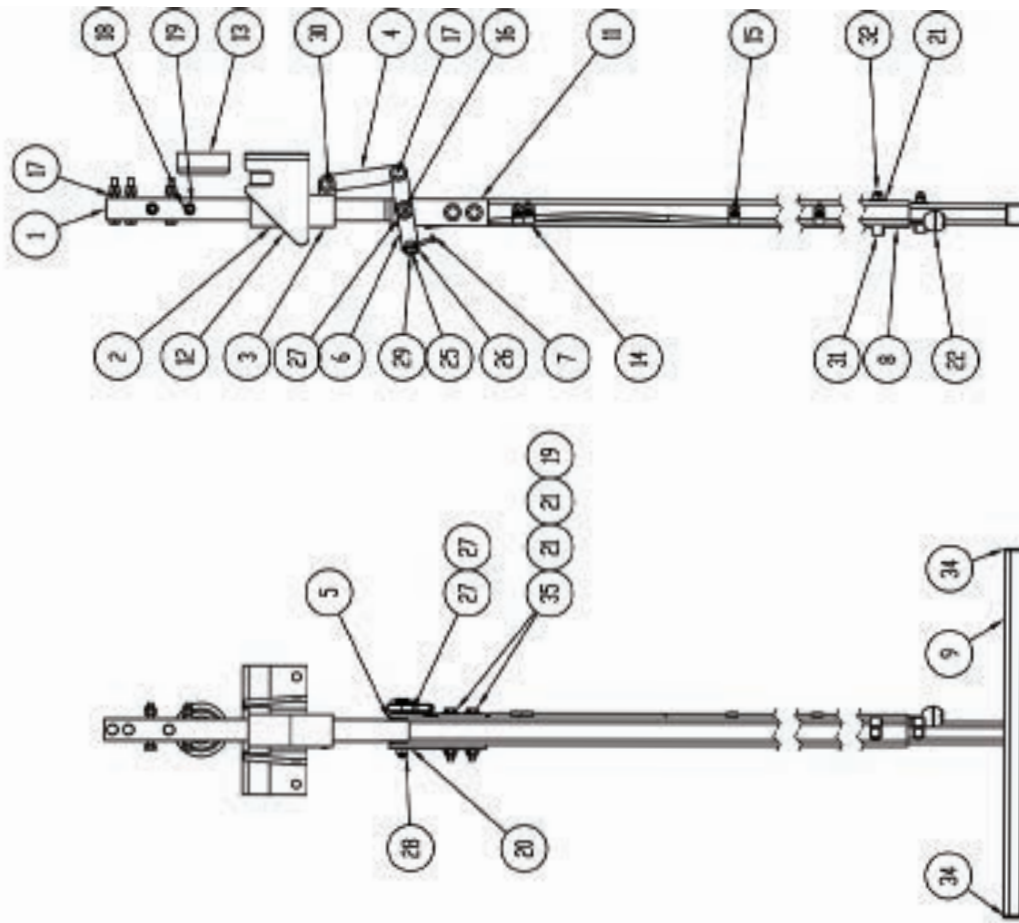

Figure 1B Pull Handle Pivoting Assembly

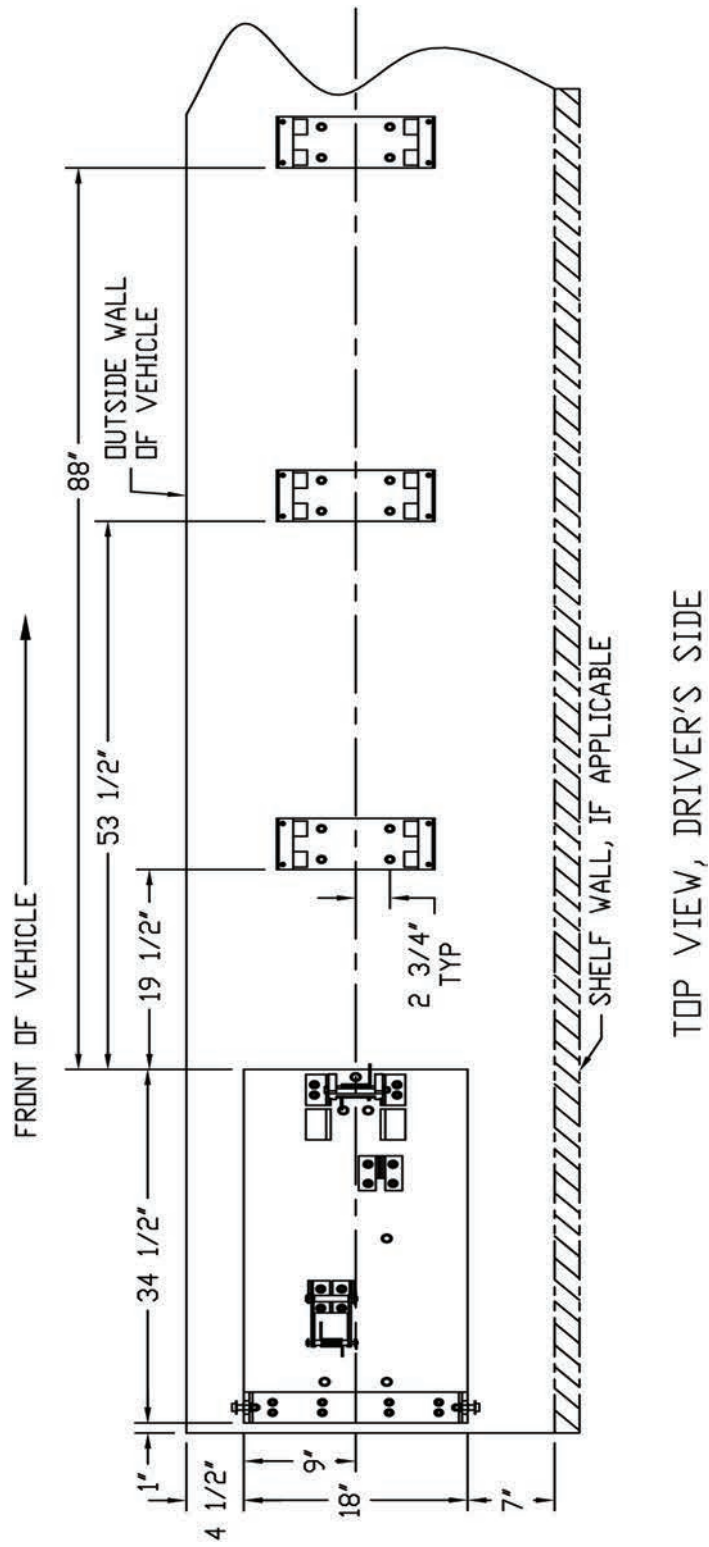

Figure 2A Dimensions - Top View, Driver's Side

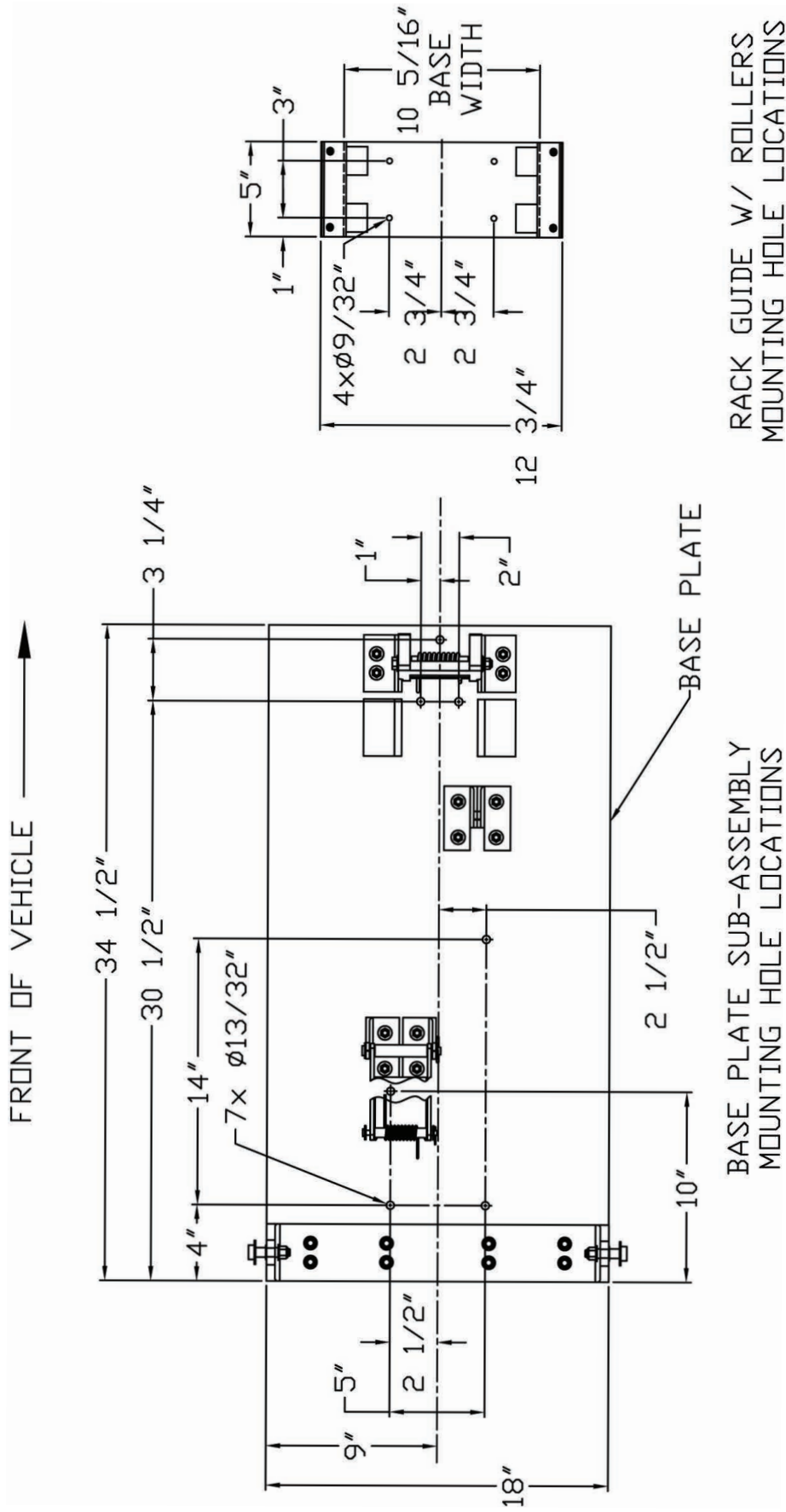

Figure 2B Dimensions - Mounting Hole Locations

I. LADDER GANTRY INSTALLATION

WARNING: Before installation, confirm that the planned mounting surface is structurally sound and capable of supporting the combined weight of the system (248 lbs.) and the ladders to be carried.

WARNING: Before installation, confirm the mounting location of the Pull Handle Catch Assembly on the rear of apparatus. This location must be properly reinforced, as the Catch Assembly will hold the entirety of the rack and ladders in place during transport.

WARNING: Before drilling into the apparatus body, confirm that there are no hidden wires, hydraulic/pneumatic lines, roll-up doors or other obstructions that could be damaged or cause injury during the drilling process.

Note: Part numbers in parentheses (see Page 2).

A. Preparing to Mount the Base Assembly

1. With assistance, lift the Combined Base Assembly (1 & 2) and attached Ladder Rack (5) onto the apparatus shelf.
2. Position the Combined Base Assembly, leaving a minimum of 7" between the Bottom Base Plate (2) and adjacent shelf side wall and 1" between the Bottom Base Plate and the rear lip of the shelf (see Figures 2A & 2B).
3. Using the Bottom Base Plate as a template, mark the seven mounting hole locations with a transfer punch, then drill the seven holes for 3/8" diameter fasteners. Do not fasten at this time.

B. Mounting the Rack Guide-Roller Assemblies

1. Position the three Rack Guide-Roller Assemblies (4) on the apparatus shelf (see Figures 2A & 2B). Shim the Rack Guides as necessary until all three are level and aligned with the Ladder Rack (5).
2. Using each Rack Guide as a template, mark the twelve mounting hole locations with a transfer punch, then drill the twelve holes for 1/4" diameter fasteners.
3. Fasten the three Rack Guides to the shelf using 1/4" Grade 8 fasteners and washers (not included).

C. Mounting the Gantry Base Assembly

1. If removed during the drilling process, return the combined Gantry Base Assembly (1 & 2) and Ladder Rack (5) to the apparatus shelf. Set the Ladder Rack into the Rack Guide-Roller Assemblies (4).
2. Fasten the Bottom Base Assembly (2) to the apparatus shelf using 3/8" Grade 8 fasteners and washers (not included).

D. Mounting the Pull Handle & Pull Handle Catch (see Figures 1B and 4)

1. Attach the Pull Handle Assy (8) to the Gantry Base Assembly using the hardware provided.
2. With the system in the fully stored position, align the Catch-Lower Handle Assy (15) with the Pull Handle on the reinforced rear wall of the apparatus. Fasten assembly to rear wall (fasteners not supplied).
3. Align Rubber Bumper (13) with Pull Handle Pivoting Rod (1) using 5/16" hardware (see Figures 1B and 4, Detail A)
4. Adhere the Striking Injury Warning Label (19) beside the Pull Handle Catch Assembly so that it is visible to the operator.

II. LADDER GANTRY OPERATION

WARNING: Do not stand under the Ladder Rack (5) when operating the system. Operator should confirm that the area around the Ladder Gantry System is clear of personnel before raising or lowering.

A. Unloading the Ladders

1. Pull on the Pull Release Knob (22) to disengage the Latch (2) on the Pull Handle Latch Receiver (12) (see Figure 1B).
2. Firmly grip the Pull Handle (9) and walk away from the apparatus. The Ladder Rack (5) will remain horizontal for approximately 76 inches, at which point it will automatically unlock and begin to tilt downward (see Figure 3B).
3. When Ladder Rack has tilted to the fully-lowered position it will automatically lock into place (see Figures 3C and 3D).
4. Lift and turn the Ladder Retaining Latch on the Ladder Stop Handle (9) that is retaining the ladder to the Ladder Rack (see Figures 1 and 4).
5. Lift the ladder up over the Ladder Rest Assembly (12). Using the walls of the Ladder Rack as a guide, slide the ladder down the Ladder Rack. Use caution not to hit the Bounce Bar (11). Repeat for all ladders (see Figures 1 and 7).

B. Loading the Ladders

1. Slide the ladder up the Ladder Rack (5) and under the Bounce Bar (11). Lower the ladder into place so that a rung sits between the padded tubes of the Ladder Rest Assembly (12). Repeat for all ladders (see Figures 1 and 7).
2. Secure the ladders to the Ladder Rack by engaging the Ladder Stop Handle (10) (see Figures 1, 4 and 7).
3. Lift the yellow Lock Release Handle (7) to unlock the Ladder Rack (see Figure 5) and raise the Ladder Rack until it locks back in the horizontal position (see Figure 6).
4. Push the Ladder Rack forward to the stored position. Secure the Pull Handle (11) in the Pull Handle Catch (9).

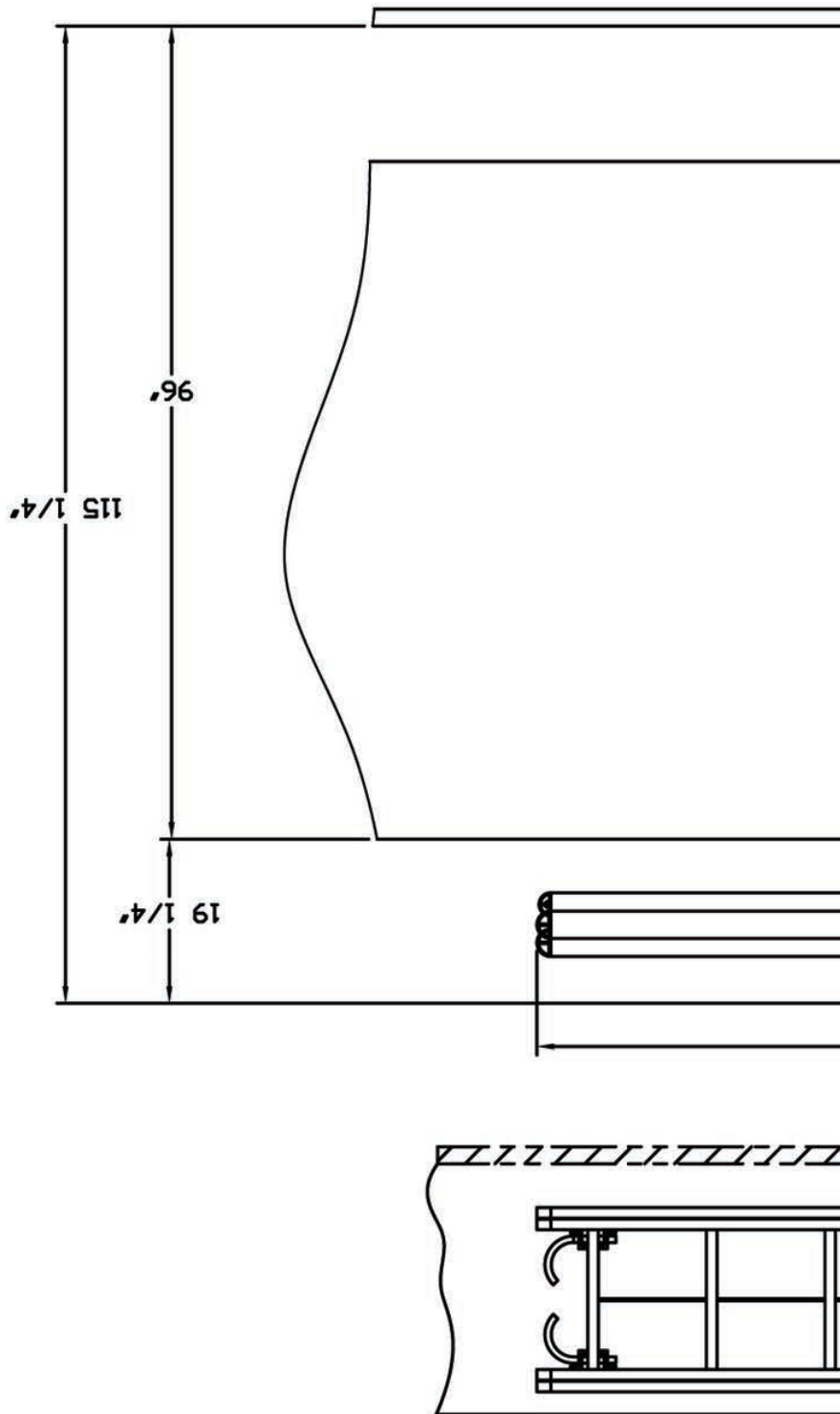

**Figure 3A Dimensions - Stored Position
(8' H Vehicle Shelf Shown)**

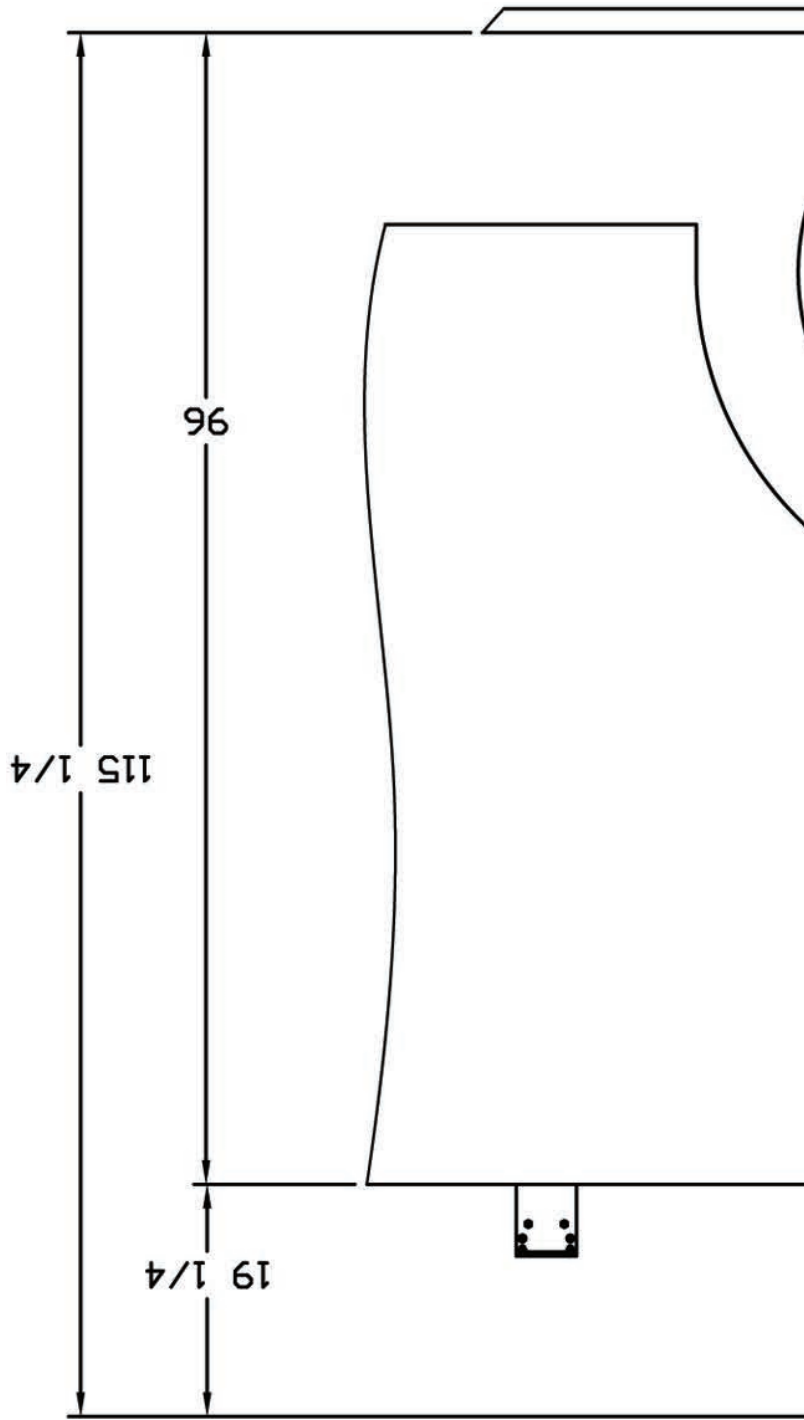

**Figure 3B Dimensions - Partial Deployment
(8' H Vehicle Shelf Shown)**

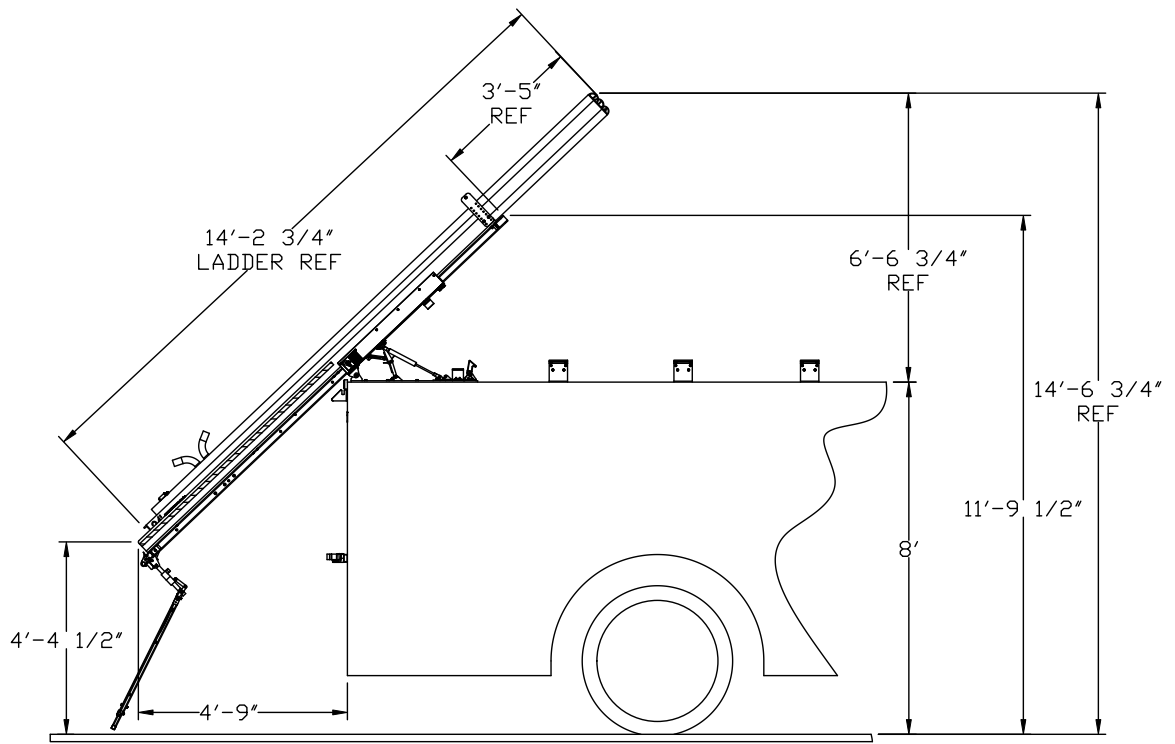

Figure 3C Dimensions - Full Deployment - 8' H Vehicle Shelf

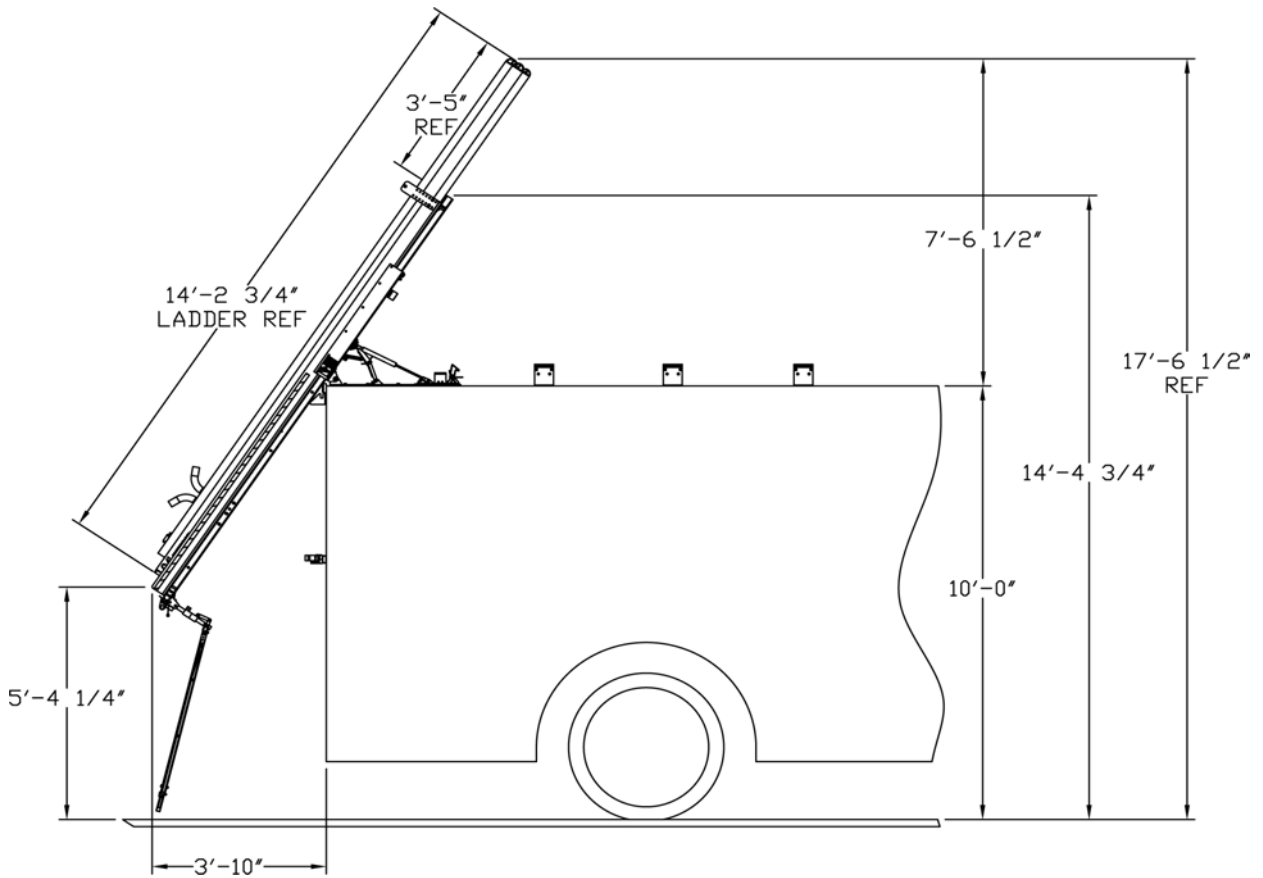
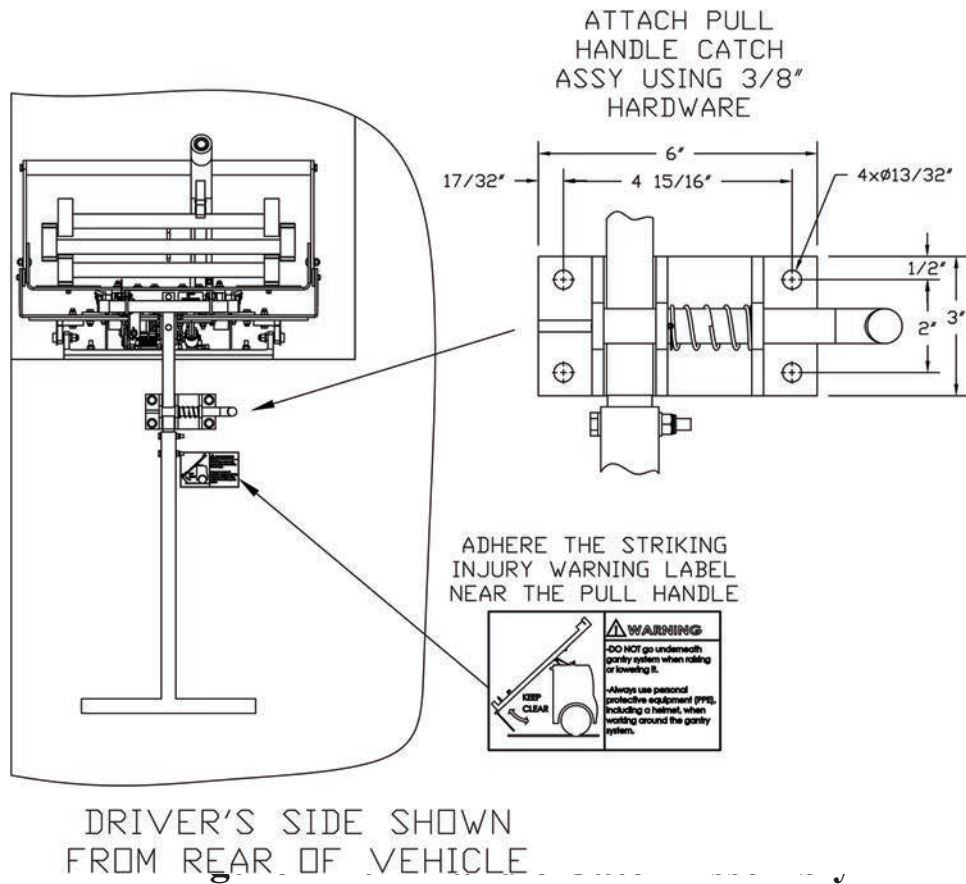

Figure 3D Dimensions - Full Deployment- 10' H Vehicle Shelf



ITEM	PART NO.	DESCRIPTION	QTY.
1		STANDOFF-LOWER HANDLE CATCH	1
2	3085-500-105	SURE GRIP BASE	1
3	3085-500-107	STRAP PLATE	1
4	3099-500-109	STRAP, VARIABLE	
5	9130-241306	SCREW, #6-20 THREAD CUTTING, SOFT PLASTIC	4
6*		SCREW, 1/4-20 x 2 1/2, TRUSS HEAD	2
7*		NUT, 1/4-20 NYLON LOCK	2
8		WASHER, #6 x .560 OD	1
9		LOCK WASHER, 1/4" EXT TOOTH	2
10	3085-500-901	PAD WITH ADHESIVE	1
11	9474K45 9474K45	RECTANGULAR PLUGS, SNAP-IN, FOR 1.83"-1.95" LONG x 0.84"-0.95" Wide Inside	2
12*		WASHER, 1/4 REGULAR	2

* NOT SUPPLIED

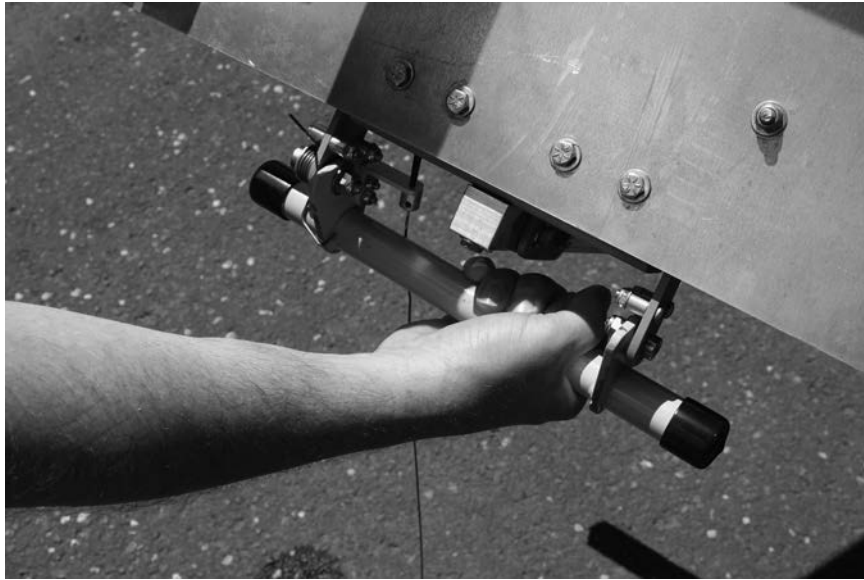

Figure 5 Lock Release Assembly

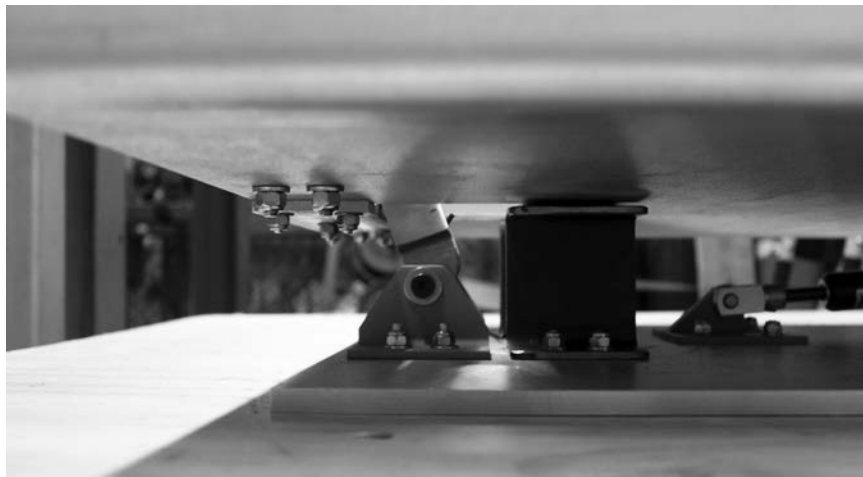

Figure 6 Gantry Pan Lock - Locked Position



Figure 7 Ladder Rest Assembly

Notes:



Ziamatic Corp.

10 West College Avenue, P.O. Box 337, Yardley, PA 19067-0587 • (215) 493-3618 • FAX: (215) 493-1401

www.ziamatic.com

TOLL FREE: 800-711-3473

*ZICO is a registered trademark for fire, safety and marine products made by Ziamatic Corp.

Copyright Ziamatic Corp. 1-22