

**HARD SLEEVE GANTRY SYSTEM  
MODEL HSG-1  
PARTS AND INSTRUCTION MANUAL**



Features:

- Makes hard sleeve retrieval a one-person operation--no climbing & no dropped sleeves
- Sleeve slides out and tilts down for easy removal with reduced risk of injury to personnel
- Maximum load: 100 lbs.

MODEL	DESCRIPTION	WT./@ IN LBS.
HSG-1-O-10	Complete unit for 10' hard sleeve - officer's side	93.0
HSG-1-D-10	Complete unit for 10' hard sleeve - driver's side	93.0
HSG-LB-C	Circular light base	3.40
HSG-LB-R	Rectangular light base	4.35

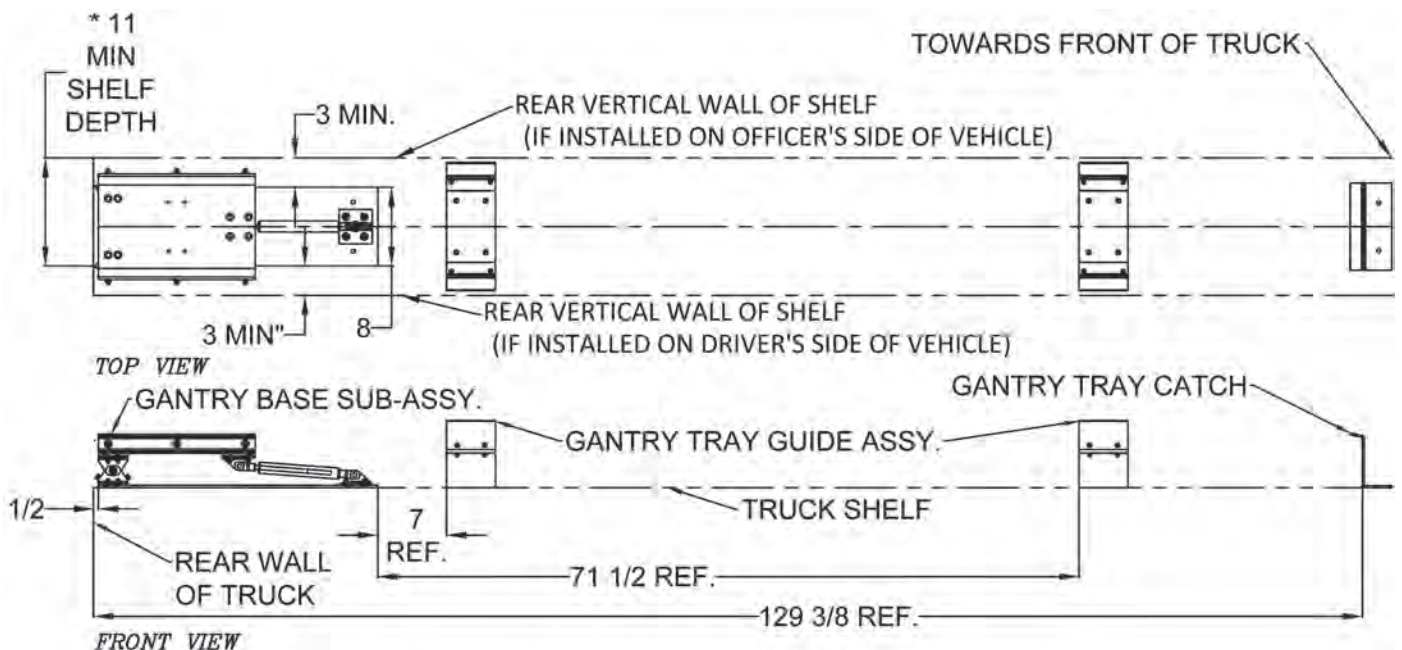

\* AT MIN. SHELF DEPTH, THERE WILL BE A MAX. 2 1/2 OVERHANG OF THE GANTRY TRAY GUIDE.

Figure 1

# Gantry Overall Dimensions

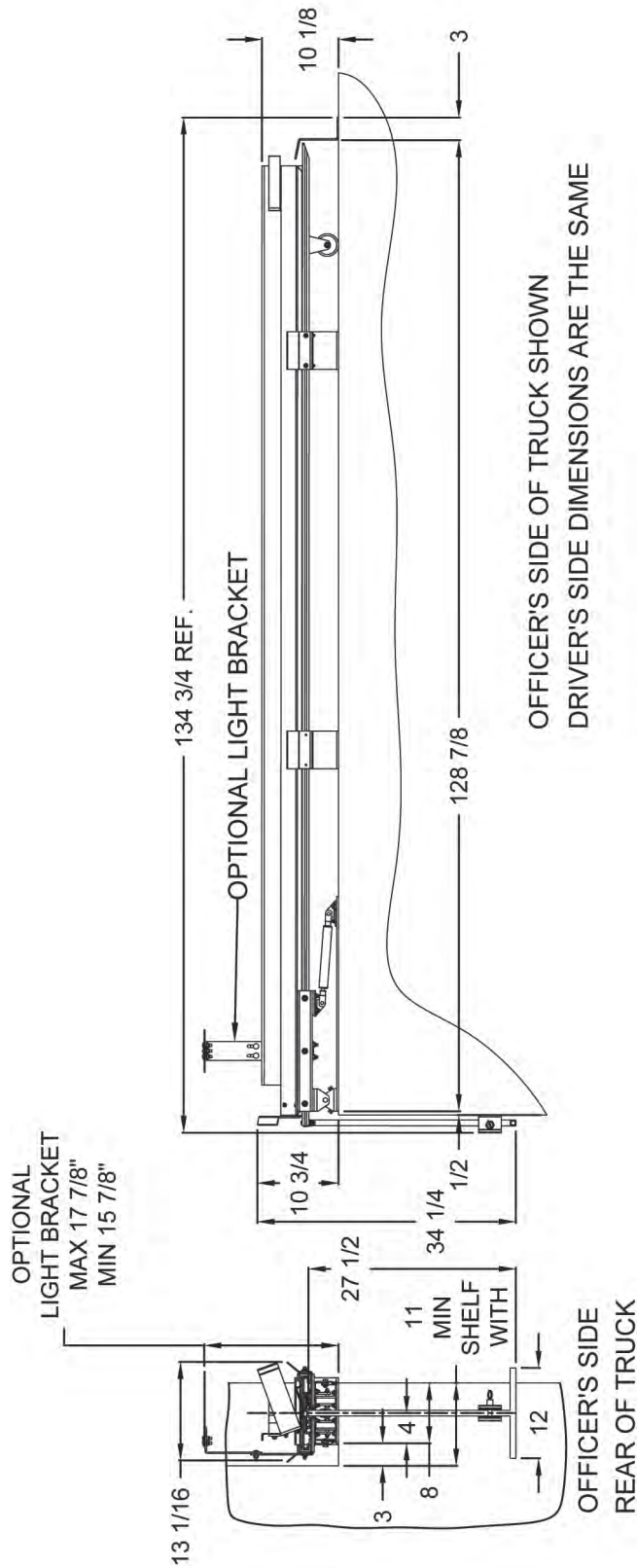

**Figure 2**

# Gantry Mounted Dimensions

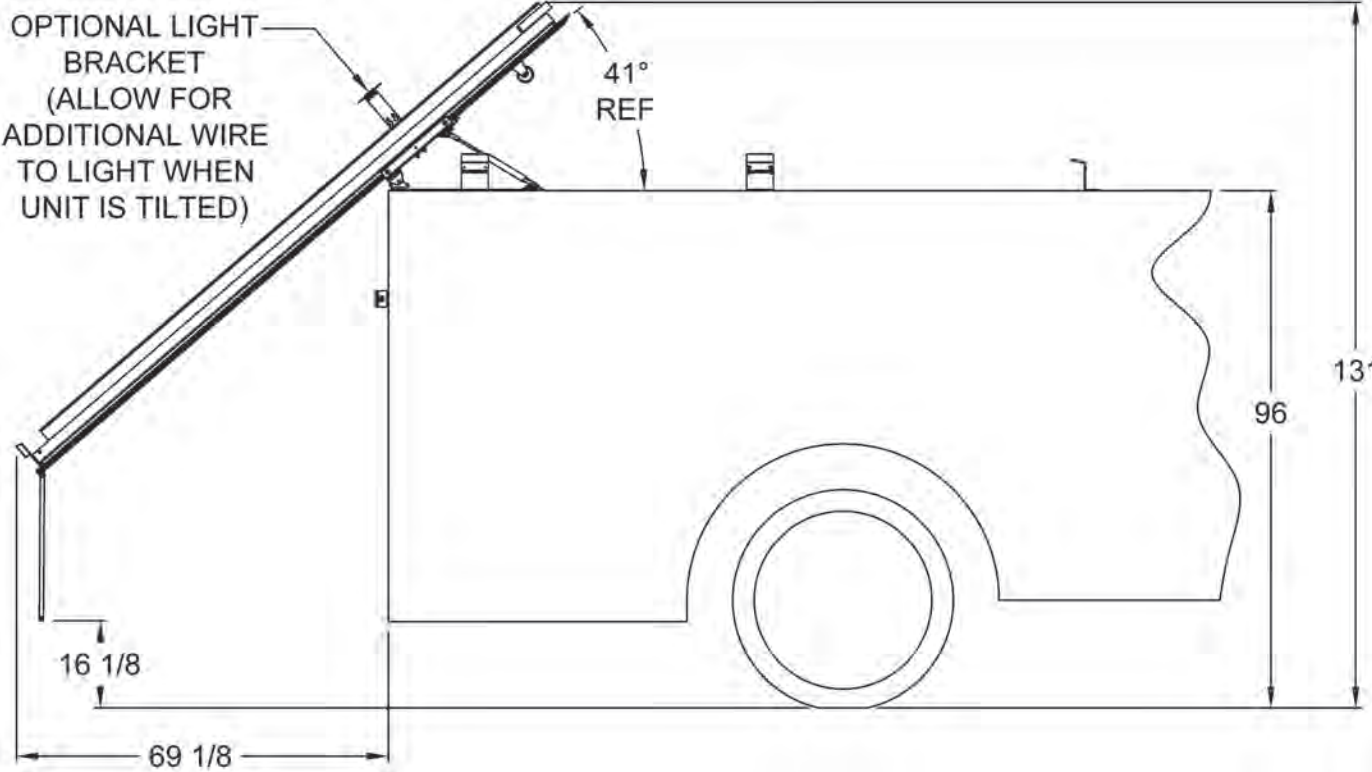
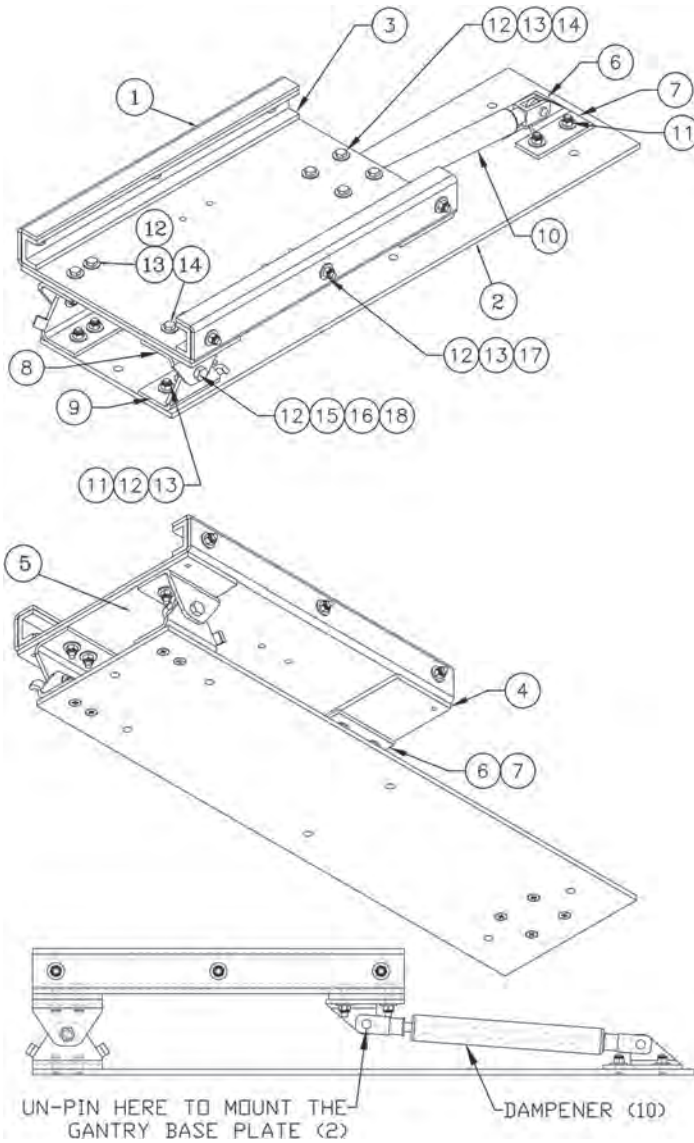

Figure 3

# Parts Diagram/Breakdown - Gantry Base Sub-Assembly



ITEM NO.	PART NO.	DESCRIPTION	QTY.
1	3093-400-121	Gantry Tray Receiver	1
2	3093-400-123	Gantry Base Plate	1
3	3093-400-125	Gantry Tray Wear Channel	2
4	3093-400-127	Gantry Tray Stiffener Upper	1
5	3093-400-129	Gantry Tray Stiffener Lower	1
6	3093-400-131	Gantry Dampener Bracket Right	2
7	3093-400-133	Gantry Dampener Bracket Left	2
8	3093-400-135	Gantry Tray Pivot	2
9	3093-400-137	Gantry Tray Pivot with Tabs	2
10	3093-400-139	Dampener, 60lb	1
11	9010-162514	1/4-20 x 7/8 Flat Head ZPS	8
12	9014-112500	1/4 Flat Washer	32
13	9013-172500	1/4-20 Nyloc Nut	22
14	9010-102520	1/4-20 x 1 1/4 Hex Head ZPS	8
15	9010-313708	3/8 x 1/2 Shoulder Bolt, 1/4-20 Thread ZPS	2
16	9013-172501	1/4-20 Nyloc Nut/Low Profile	2
17	9010-162516	1/4-20 x 1 Flat Head ZPS	6
18	3093-400-153	Nylon Washer, 3/8 ID	2

**Figure 4**

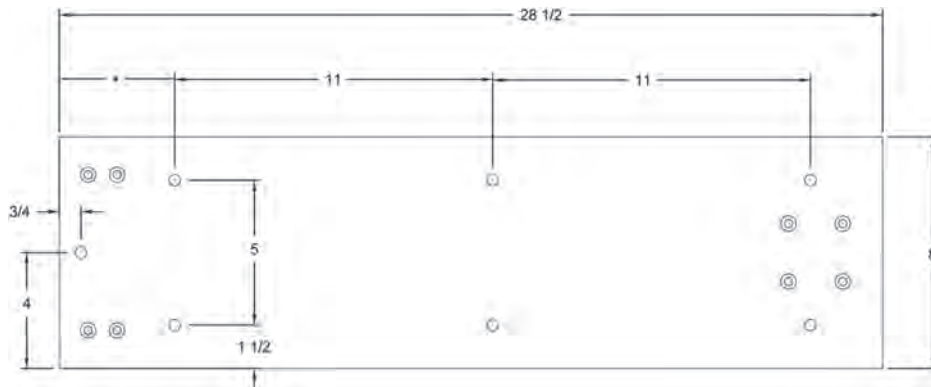

**Figure 5 Gantry Base Plate (1/4" Thick)**

# Parts Diagram/Breakdown - Gantry Tray Guide Assembly

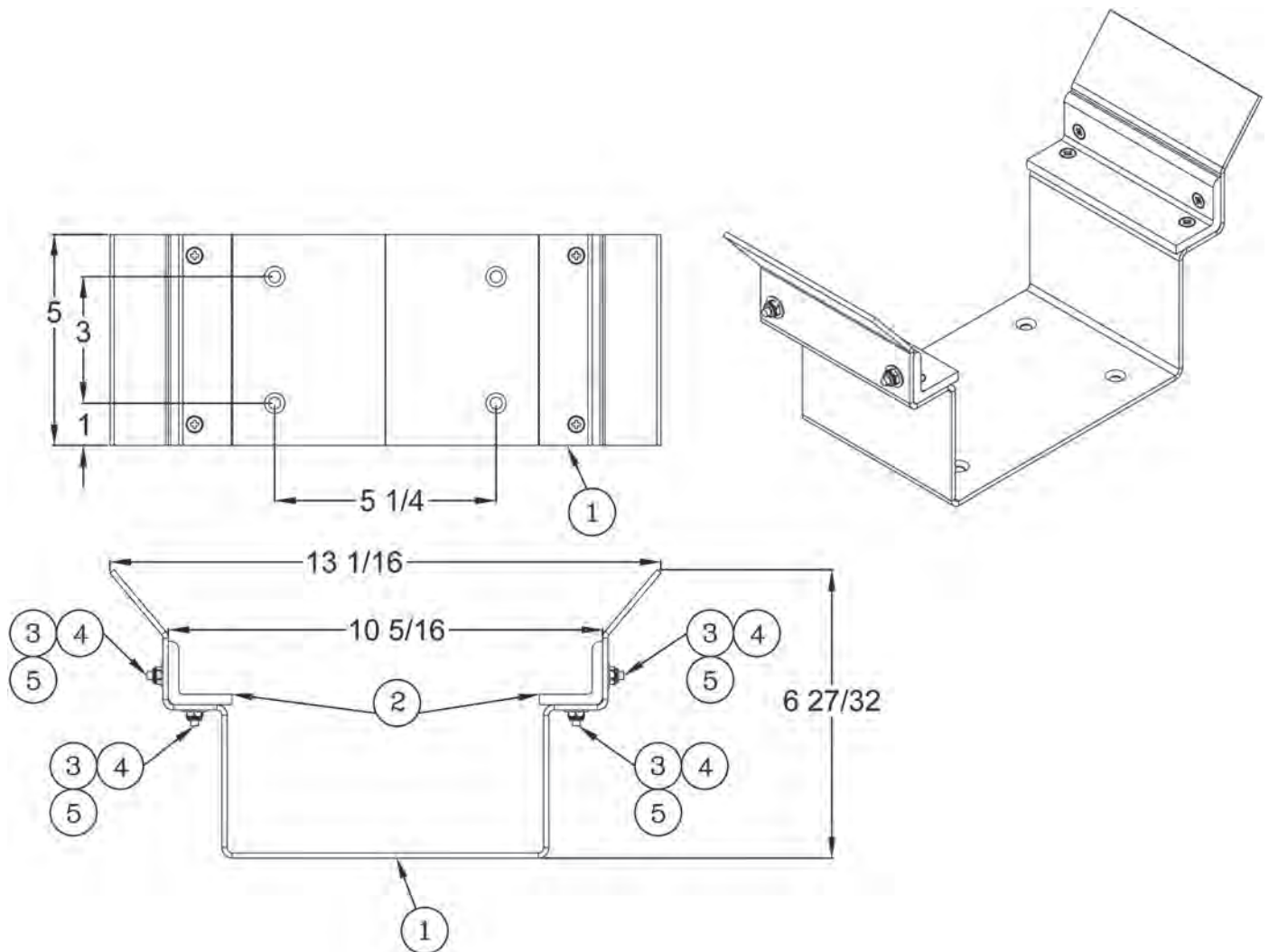

**Figure 6**

ITEM NO.	PART NO.	DESCRIPTION	QTY.
1	3093-400-117	Gantry Tray Guide	1
2	3093-400-119	Gantry Tray Wear Angle	2
3	9010-162012	#10-32 x 3/4 Flat Head ZPS	8
4	9014-112000	#10 Washer	16
5	9013-172000	#10-32 Nyloc Nut/Low Profile	8



# Parts Diagram/Breakdown - Gantry Tray Assembly (Officer's Side)

ITEM NO.	PART NO.	DESCRIPTION	QTY.
1	3093-400-101	Gantry Main Rail	1
2	3093-400-103	Hard Suction Tray for Gantry, Officer Side	1
4	3093-400-107	Gantry Wheel Bracket for 3" Wheels	1
6	3093-400-111	Gantry Hose Catch	1
7	3093-400-113	Black 3" Wheel 3/8" Axle	2
8	3093-400-115	Gantry Hose Stop	1
9	9010-162512	1/4-20 x 3/4 Flat Head Phil ZPS	12
12	9014-112500	Washer 1/4" Nom.	18
13	9013-172500	1/4-20 Nylock Nut	18
14	9010-623726	3/8 x 5/8 Shoulder Bolt, 1/4-20 x 3/4 Thd	2
15	3093-400-147	Gantry Tray Stop Bracket	1
16	9010-573125	Full Threaded Stud 5/16-18 x 1 1/2" ZPS	2
17	9014-203100	5/16 Lock Washer ZPS	2
18	1027-105-133	Red Cylinder Stop, 5/16-18	2
19	9012-113100	5/16 Nut ZPS	2
20	9010-102516	1/4-20 x 1" Flat Head Phil ZPS	4
21	3093-400-151	Pad with Tape	1

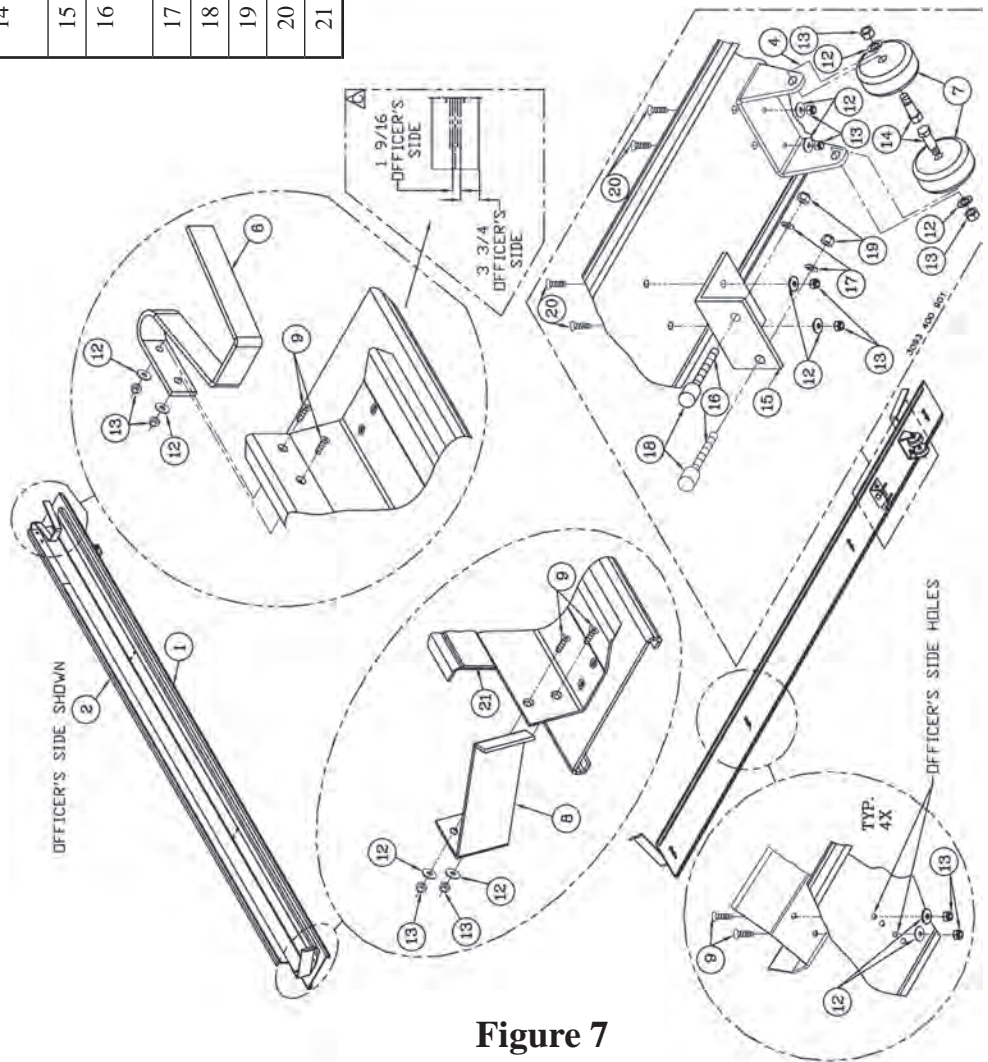

Figure 7

# Parts Diagram/Breakdown - Gantry Tray Assembly (Driver's Side)

ITEM NO.	PART NO.	DESCRIPTION	QTY.
1	3093-400-101	Gantry Main Rail	1
2	3093-405-103	Hard Suction Tray for Gantry, Driver's Side	1
4	3093-400-107	Gantry Wheel Bracket for 3" Wheels	1
6	3093-400-111	Gantry Hose Catch	1
7	3093-400-113	Black 3" Wheel 3/8" Axle	2
8	3093-400-115	Gantry Hose Stop	1
9	9010-162512	1/4-20 x 3/4 Flat Head Phil ZPS	12
12	9014-112500	Washer 1/4" Nom.	18
13	9013-172500	1/4-20 Nylock Nut	18
14	9010-623726	3/8 x 5/8 Shoulder Bolt, 1/4-20 x 3/4 Thd	2
15	3093-400-147	Gantry Tray Stop Bracket	1
16	9010-573125	Full Threaded Stud 1/40-20 x 1 1/2" ZPS	2
17	9014-203100	5/16 Lock Washer ZPS	2
18	1027-105-133	Red Cylinder Stop, 5/16-18	2
19	9012-113100	5/16 Nut ZPS	2
20	9010-102516	1/4-20 x 1" Flat Head Phil ZPS	4
21	3093-400-151	Pad with Tape	1

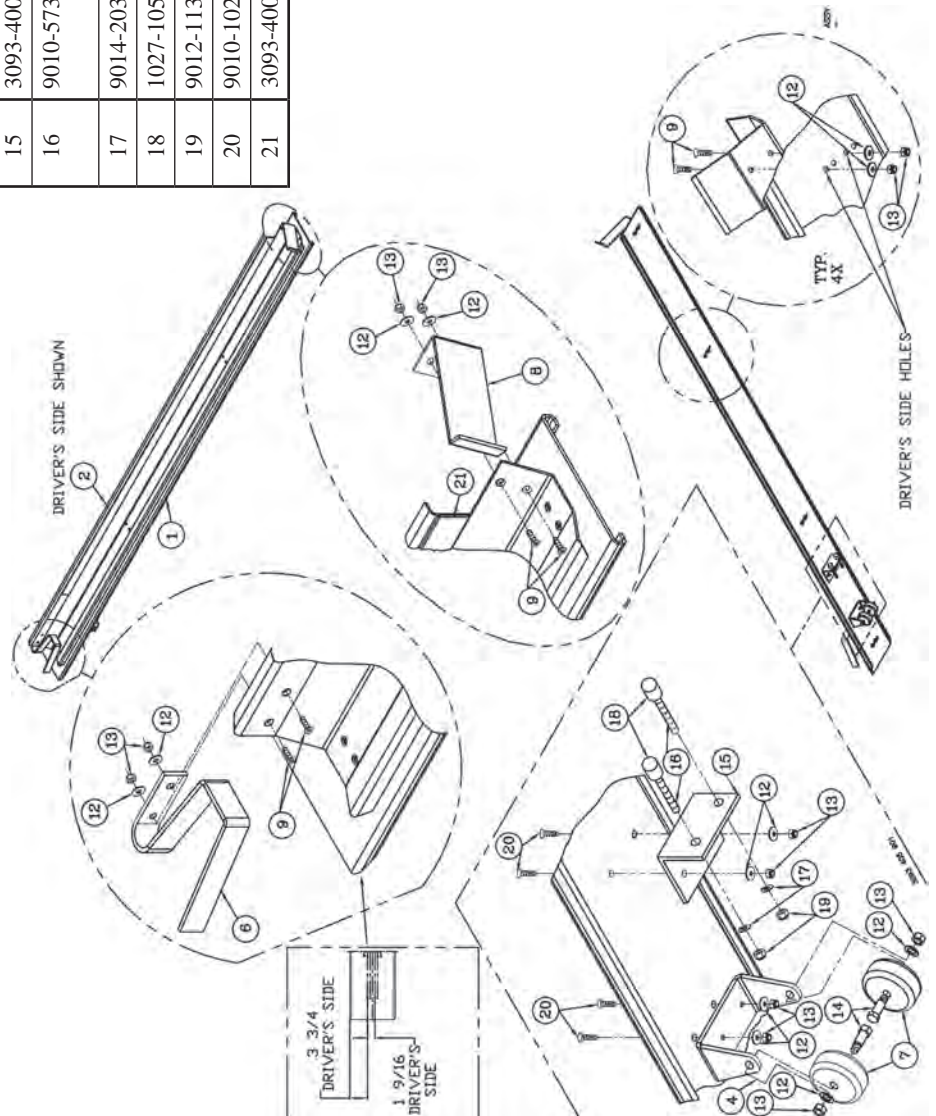
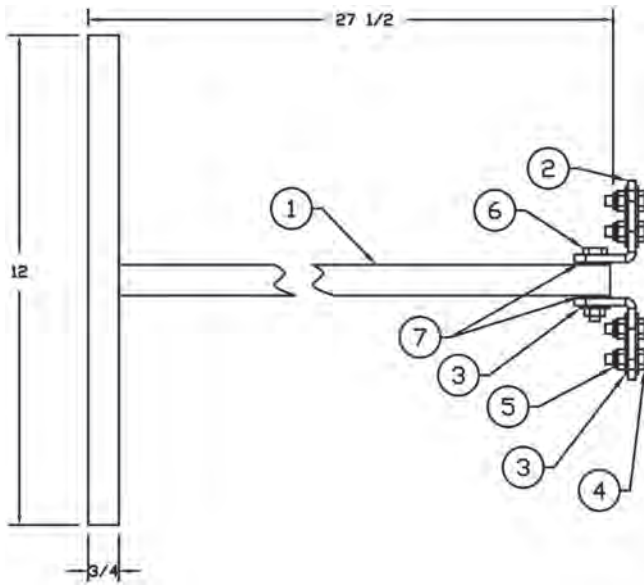

Figure 7A

## Parts Diagram/Breakdown - Gantry Handle Sub-Assembly



ITEM NO.	PART NO.	DESCRIPTION	QTY.
1	3093-400-109	Gantry Pull Handle	1
2	3093-400-105	Gantry Pull Bracket	2
3	9014-112500	Washer 1/4" Nom.	5
4	9010-102516	1/4-20 x 1 Hex Head ZPS	4
5	9013-172500	1/4-20 Nylock Nut	5
6	9010-313120	5/16 x 1-1/4 Shoulder Bolt, 1/4-20 x 3/4 Thd	1
7	3093-400-153	Nylon Washer, 3/8 ID	2

Figure 8

## Parts Diagram/Breakdown - Gantry Rod-Catch Sub-Assembly

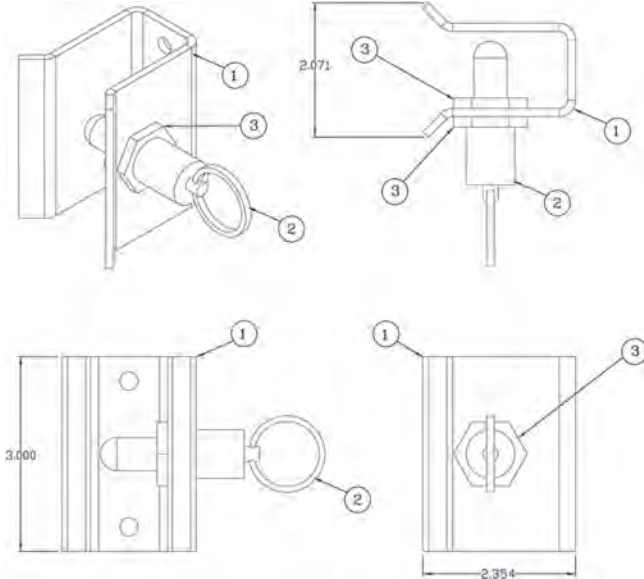

ITEM NO.	PART NO.	DESCRIPTION	QTY.
1	3093-400-141	Gantry Rod Catch	1
2	3093-400-143	Spring Loaded Latch Stainless Steel	1
3	9012-107500	Nut 3/4-16, Ultra Low Profile	2

Figure 9



# Dimensions - Gantry Tray Stop

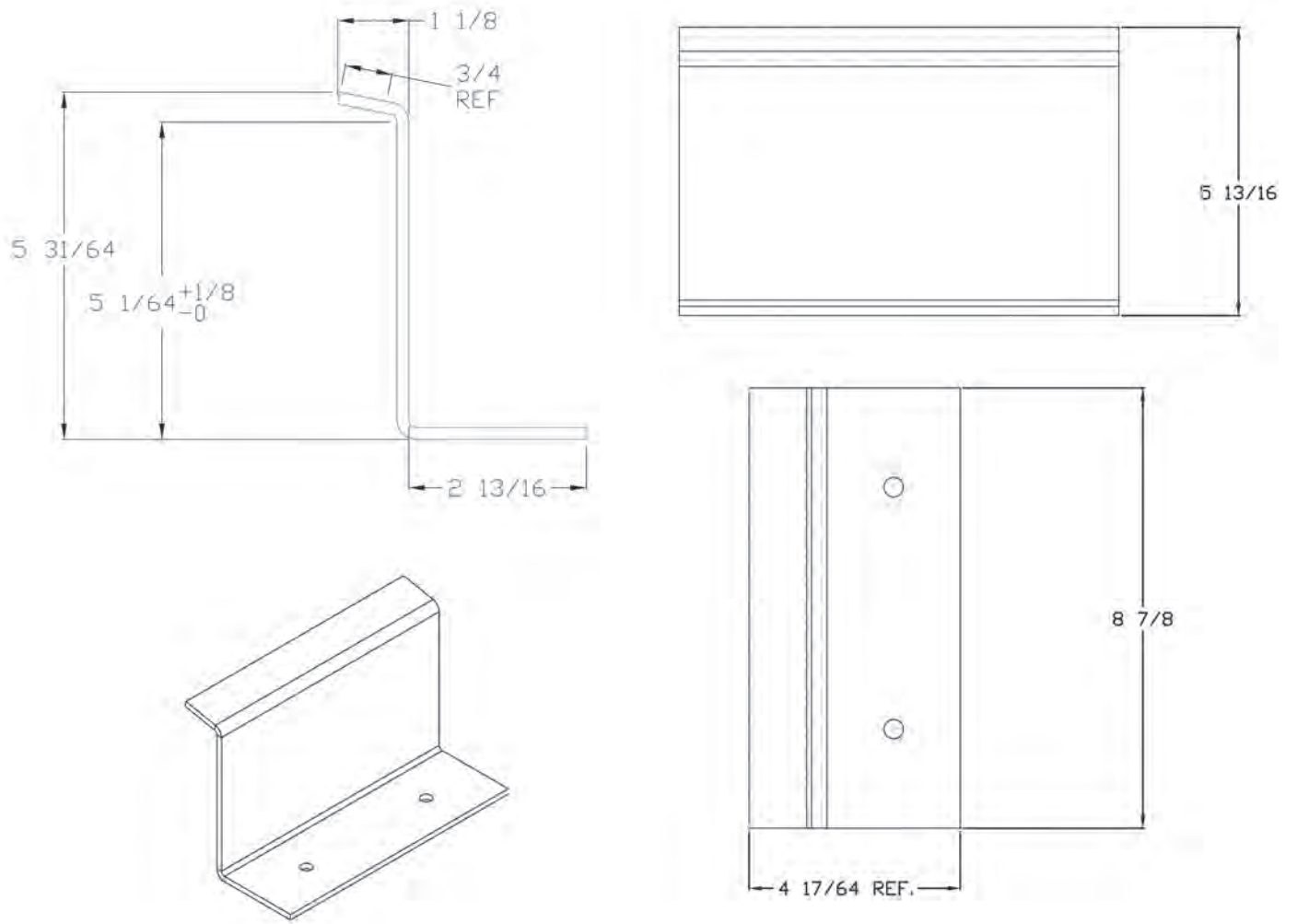
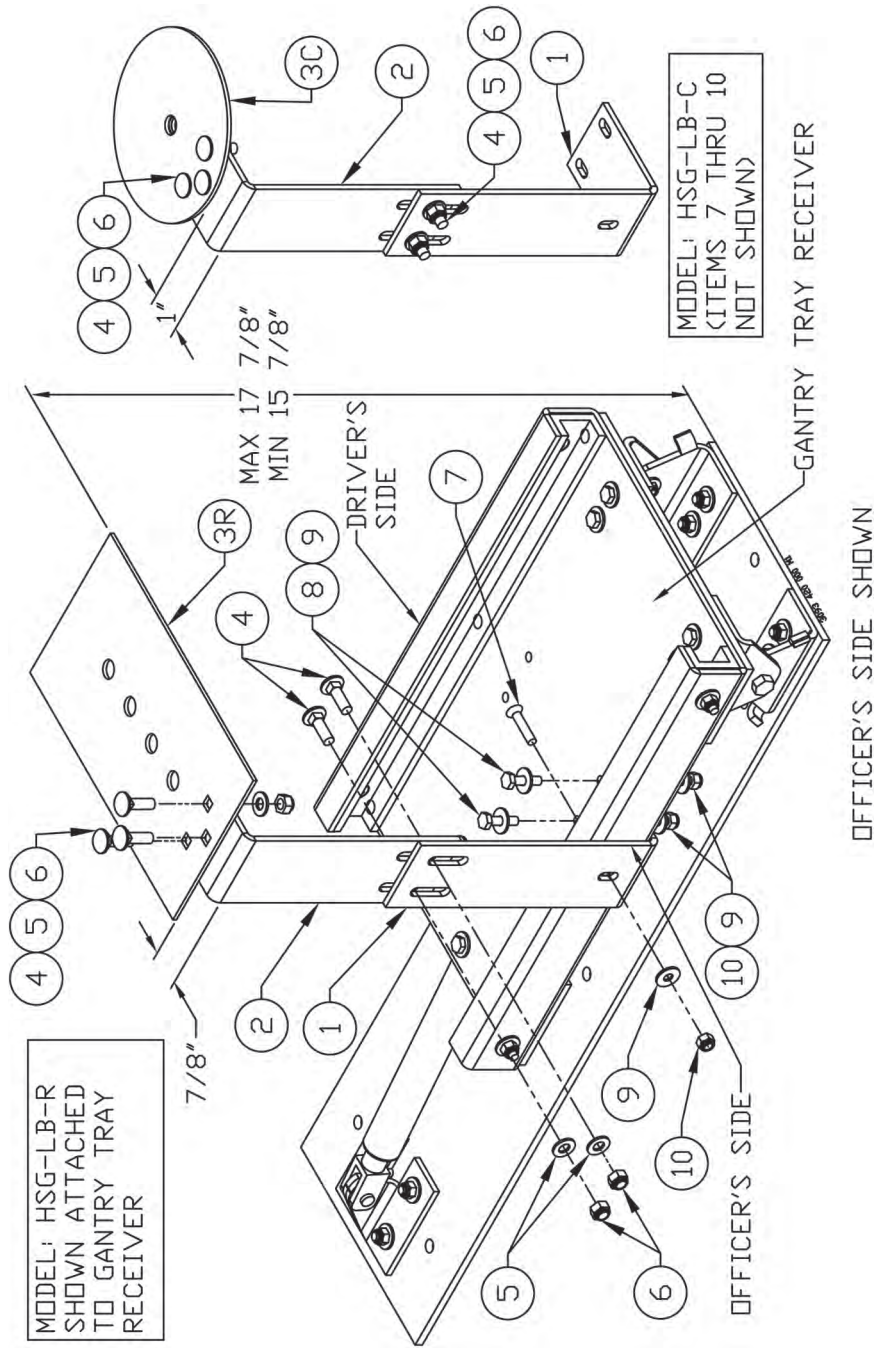

Figure 10

# Parts Diagram/Breakdown - Optional Light Brackets



**Figure 11**

ITEM	PART #	DESCRIPTION	QTY.
1	3093-420-101	Bracket, Bottom	1
2	3093-420-103	Bracket, Top	1
3C	3093-420-105	Plate, Circular	1
3R	3093-425-105	Plate, Rectangular	1
4	9010-343116	5/16-18 x 1", Sq Neck (Carriage) ZPS	5
5	9014-183100	5/16 Washer GR8 ZPS	5
6	9013-173100	5/16-18, Nut Nylon Locking	5
7	9010-162520	1/4-20 x 1-1/4, PHL Flat Hd, ZPS	1
8	9010-102516	1/4-20 x 1, Hex Head	2
9	9014-112500	1/4 Washer, Flat	5
10	9013-172500	1/4-20 Nut, Nylon Locking	3

# Dimensions - Optional Light Brackets

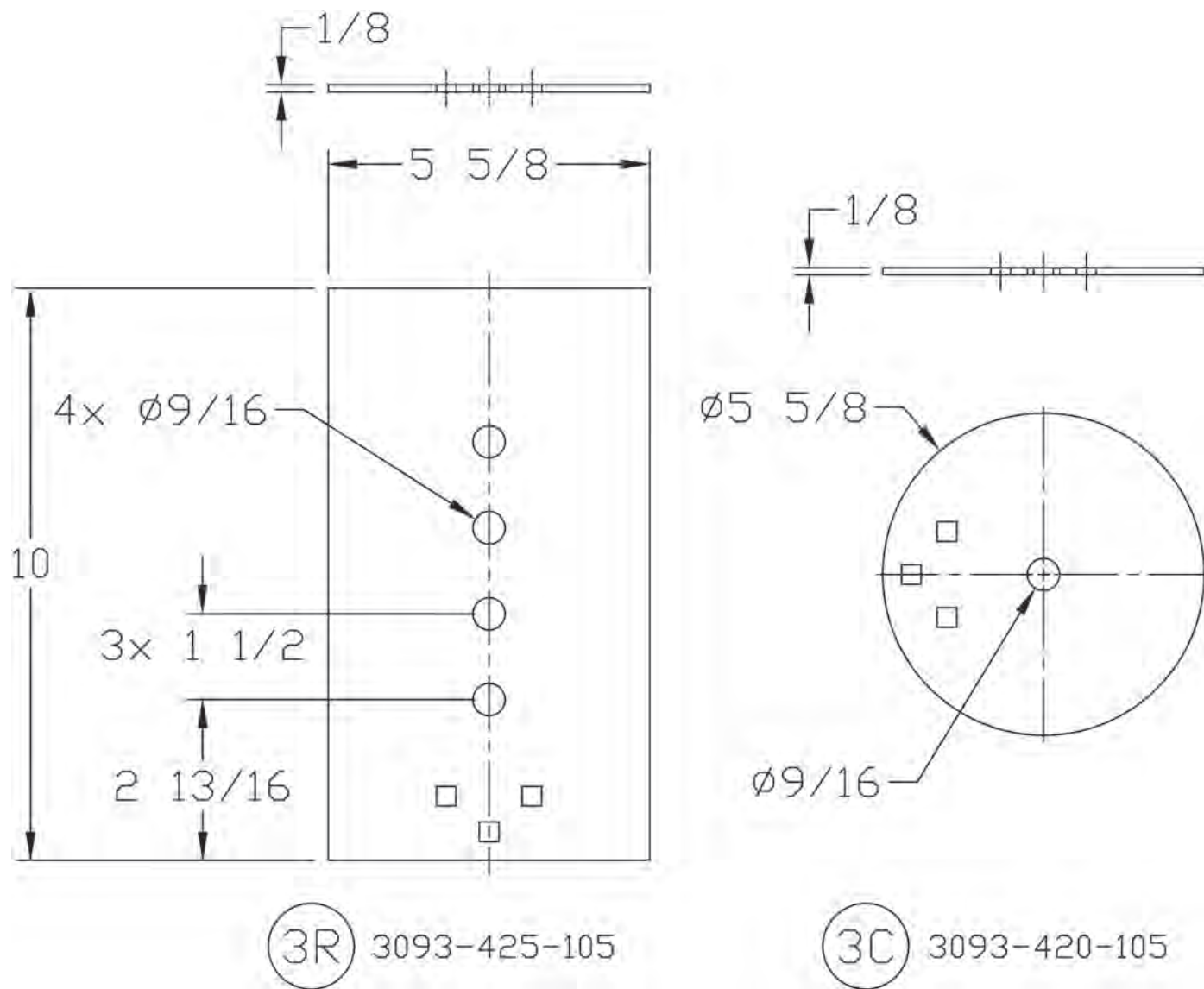

**Figure 12**

## Mounting Instructions

---

*WARNING: Before drilling into the apparatus body, confirm that there are no hidden wires, hydraulic/pneumatic lines, roll-up doors or other obstructions that could be damaged or cause injury during the drilling process.*

*WARNING: Do not paint the Gantry Main Rail (Figure 7 & 7A, Item 1). Anodizing is acceptable if color is required.*

Note: If standard Pull Handle (Page 8) will not work with your vehicle specifications, a custom handle can be requested by emailing (j dj@ziamatic.com) or faxing (866-493-1401) the form on Page 14.

### A. Preparing the Gantry Base Sub-Assembly

1. Position the Gantry Base Plate (Figure 1, Top View and Figure 4, Item 2) on the apparatus shelf, leaving 1/2" between Gantry Base Plate and rear lip of shelf and 3" between Gantry Base Plate and adjacent side wall.
2. Remove pin from the dampener (Figure 4, Item 10) and tilt Gantry Tray Receiver (Figure 4, Item 1) so that top of Gantry Base Plate (Figure 4, Item 2) is accessible.
3. Using the holes in the Gantry Base Plate (Figure 4, Item 2) as a template, drill six holes for 3/8" fasteners (not included). Do not fasten at this time.

Note: If installing an optional Light Bracket, see Pages 10 & 11 before beginning Gantry mounting. Keep in mind that Light Bracket will require additional wiring. To prepare installation of Light Bracket to Gantry, remove the fastener in the center of the Gantry Tray Receiver on either the Officer or Driver's side (Figure 11) and fasten Light Bracket Bottom onto Gantry Tray Receiver. The remainder of the Light Bracket assembly will be added later in the process.

4. Reattach the dampener (Figure 4, Item 10).

### B. Mounting the Gantry Tray Guide and Gantry Tray Assemblies (Figure 6, 7, & 7A)

1. Following the dimensions in Figure 1, position Gantry Tray Guides (Figure 6, Item 1) on apparatus shelf.

Note: Dimensions are referenced. The Guides can be moved slightly to pickup supports or to avoid wire harnesses, etc.

2. Slide the Gantry Tray Assembly (Figure 4 or 4A) into the rear of the Gantry Tray Receiver (Figure 4, Item 1). Confirm proper alignment between Gantry Tray Receiver and Gantry Tray Guides. Remove Gantry Tray Assembly.

## Mounting Instructions (continued)

---

3. Using holes in each Gantry Tray Guide as a template, drill four holes for 1/4" fasteners (not included). Attach Gantry Tray Guides to apparatus using 1/4" fasteners. Attach Gantry Base Plate (Figure 4, Item 2) to apparatus using 3/8" fasteners.
  4. Return Gantry Tray Assembly to Gantry Tray Receiver and Gantry Tray Guides.
- C. Mounting the Gantry Handle Assembly and Rod-Catch (Figures 8 & 9)
1. Attach Gantry Pull Brackets (Figure 5, Item 2) to the Gantry Main Rail (Figure 7 or 7A, Item 1). Handle should hang approximately perpendicular to the Gantry Main Rail, resting flush against the rear body of the apparatus.
  2. Align the Gantry Rod Catch (Figure 9, Item 1) with the Gantry Pull Handle. Position Gantry Rod Catch at your desired height.
  3. Using the holes in the Gantry Rod Catch as a template, drill two holes for 1/4" fasteners (not included). Attach Gantry Rod Catch to apparatus body using 1/4" fasteners.
- D. Mounting the Gantry Tray Stop (Figure 10)
1. With the Gantry Tray Assembly (Figure 7 or 7A) in the stored position, place the Gantry Tray Stop on the apparatus shelf, flush with the cab-end of the Gantry Main Rail (Figure 4 or 4A Item 1).
  2. Using the holes in the Gantry Tray Stop as a template, drill two holes for 3/8" fasteners (not included). Attach Gantry Tray Stop using 3/8" fasteners.
- E. Optional Light Bracket Mounting Continued (skip if not applicable)
1. Complete assembly of the Light Bracket components (Figure 11) and wire the light as per light manufacturer's recommendations.



## Operation Instructions

---

### A. Unloading Hard Sleeve

*WARNING: When hard sleeve is removed from the Gantry, the Gantry Tray will spring upward slightly. Use caution when removing hard sleeve from tray.*

1. Pull spring-loaded latch to release Gantry Pull Handle.
2. Standing at rear of the apparatus, pull the Gantry Pull Handle as you walk backwards. Gantry Tray Assembly will begin to tilt down as it moves through the Gantry Tray Receiver.
3. When Gantry Tray assembly is fully tilted down, remove straps from hard sleeve. Lift lower end of hard sleeve and slide freed sleeve down the Hose Tray.

### B. Loading Hard Sleeve

1. Confirm that straps are clear of Hose Tray. Slide Hard Sleeve upward along the tray until it engages with the Gantry Hose Catch.
2. Rest the lower end of the hard sleeve in the tray against the Gantry Hose Stop.
3. Use straps to secure the hard sleeve in place.
4. Using the Gantry Pull Handle, lift the Gantry Tray Assembly until it is level with the apparatus shelf. Slide the Gantry Hose Tray into the Tray Receiver until contact is made with Gantry Tray Stop.
5. Secure the handle with the spring-loaded latch into the Rod Catch Assembly.



**Ziamatic Corp.**

10 West College Avenue, P.O. Box 337, Yardley, PA 19067-0587 • (215) 493-3618 • FAX: (215) 493-1401

[www.ziamatic.com](http://www.ziamatic.com)

TOLL FREE: 800-711-3473

\*ZICO is a registered trademark for fire, safety and marine products made by Ziamatic Corp.

Copyright Ziamatic Corp. 5-17

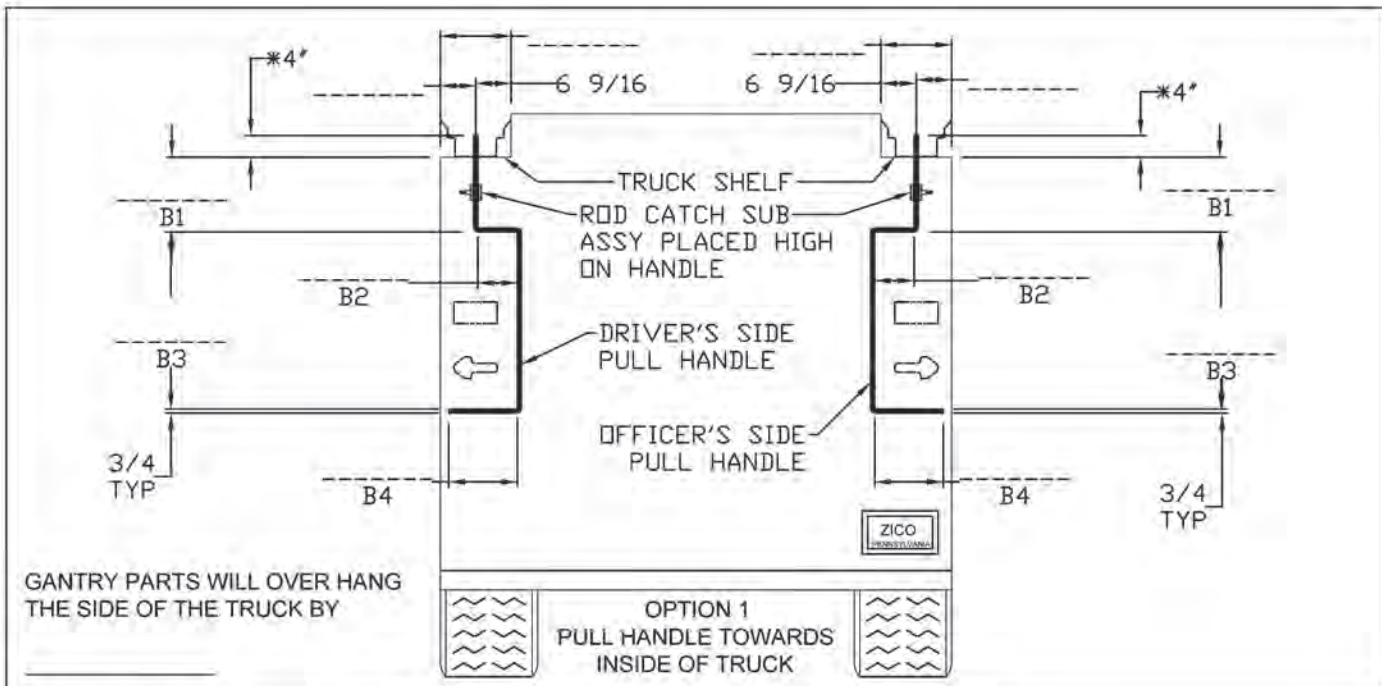

Gantry must be placed on the shelf based on the 6 9/16" distance.

REAR OF TRUCK SHOWN IN ALL OPTIONS

DRIVER'S SIDE       OFFICER'S SIDE  
 DRIVER'S SIDE AND OFFICER'S SIDE

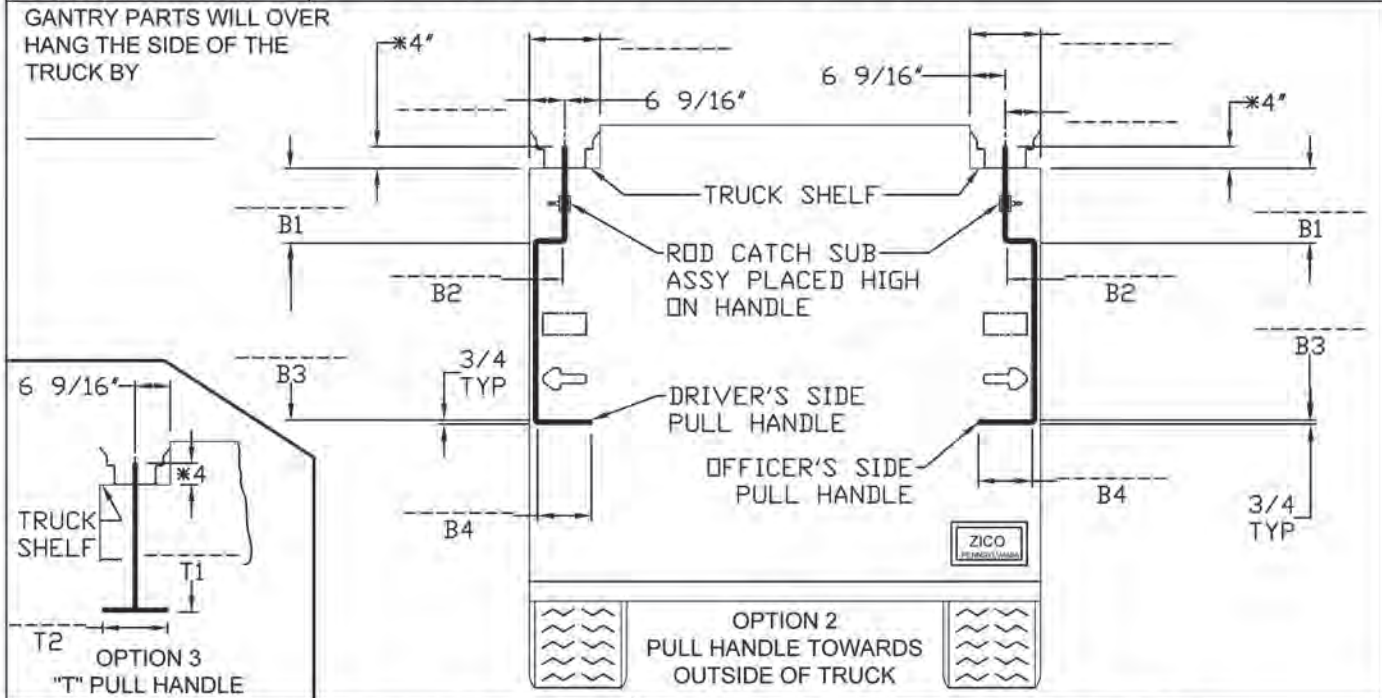

**Important:** The Driver's Side and Officer's Side units are different. Supply the following information for the specific side. If the truck is going to get a gantry on both sides, please specify that above.  
 \* 4" is the additional length needed for the handle. This is for reference only.

LIGHT: ROUND  OR RECTANGULAR

LIGHT MODEL # \_\_\_\_\_

Ziamatic Manual Hard Sleeve Gantry Pull Handle Form

Approved By: \_\_\_\_\_ CO: \_\_\_\_\_

Email Address: \_\_\_\_\_

PO: \_\_\_\_\_ Date: \_\_\_\_\_

Fax: 866-493-1401      Dwg: HSG-FORM

06/10/16