

HORIZONTAL HARD SUCTION MOUNT KITS**MODELS HHS-TM-1, HHS-TM-2, HHS-TM-1-ST, HHS-TM-2-ST,
HHS-TMV-2, HHS-TMV-2-ST****PARTS AND INSTRUCTION MANUAL****I. SYSTEMS AVAILABLE**

- A. HHS-TM-1: Horizontal Hard Suction Mounting Kit with (1) 10' Tray. (Figure 1)
- B. HHS-TM-2: Horizontal Hard Suction Mounting Kit with (2) 10' Trays. (Figure 2)
- C. HHS-TM-1-ST: Horizontal Hard Suction Mounting Kit with (1) 10' Split Tray. (Figure 3)
- D. HHS-TM-2-ST: Horizontal Hard Suction Mounting Kit with (2) 10' Split Trays. (Figure 4)
- E. HHS-TMV-2: Vertical Hard Suction Mounting Kit with (2) 10' Trays. (Figure 5)
- F. HHS-TMV-2-ST: Vertical Hard Suction Mounting Kit with (2) 10' Split Trays. (Figure 6)

CAUTION: Check for hidden hydraulic lines, pneumatic lines, wires, etc. before drilling into the apparatus.

II. ATTACHING THE TRAY TO MOUNTING BRACKETS

Note: Tray can be cut down to accommodate a hard sleeve that is less than 10' long.

- A. Review the figure associated with your particular kit. In the following steps, refer to your kit system's figure along with any other figure called out specifically in the following steps.
- B. Center the two brackets at an equal distance from each other on the apparatus shelf or other desired location. It is ideal to mount brackets to a structural member of the mounting surface. If not, a backer plate may be required if the mounting surface is less than 1/8" thick aluminum or 1/16" thick steel. See Figures 9A & 9B for specifics.
- C. Center the tray on the brackets, making sure there is enough clearance to wrap the top of the strap through the footman's loop (to be attached later). See Figure 7.
- D. Mark the location of the brackets on the tray and on the apparatus.
- E. Clamp the bracket onto the tray and, using the holes in the brackets as guides, drill $\varnothing 9/32$ " holes through the tray. Repeat with the other bracket. See Figure 8.
- F. Drill $\varnothing 7/32$ " holes for the footman's loops on each end of the tray. Do not fasten them to the tray at this time. See Figure 8.
- G. Fasten, but do not overly tighten, the tray to the bracket with the hardware provided.

III. ATTACHING THE MOUNTING BRACKETS TO THE APPARATUS

- A. Place the tray assembly onto the apparatus. Mark the location of the brackets and drill $\varnothing 9/32$ holes through the mounting surface. See Figure 9.
- B. If a backer plate is to be used, drill $\varnothing 9/32$ holes at the locations shown in Figures 9A & 9B.
- C. Fasten the assembly to the mounting surface using 1/4" hardware (customer supplied).
- D. Securely tighten all 1/4" fasteners.

IV. ATTACHING THE STRAP

- A. Feed the sewn loop end of the strap over the bottom footman's loop. See Figure 7.
- B. Fasten both the bottom and the top footman's loops using the #10 hardware that is provided with the kit. See Figure 7 & 8.
- C. Place the hard sleeve on the tray and secure it by feeding the other end of the strap through the top footman's loop. See Figure 7.

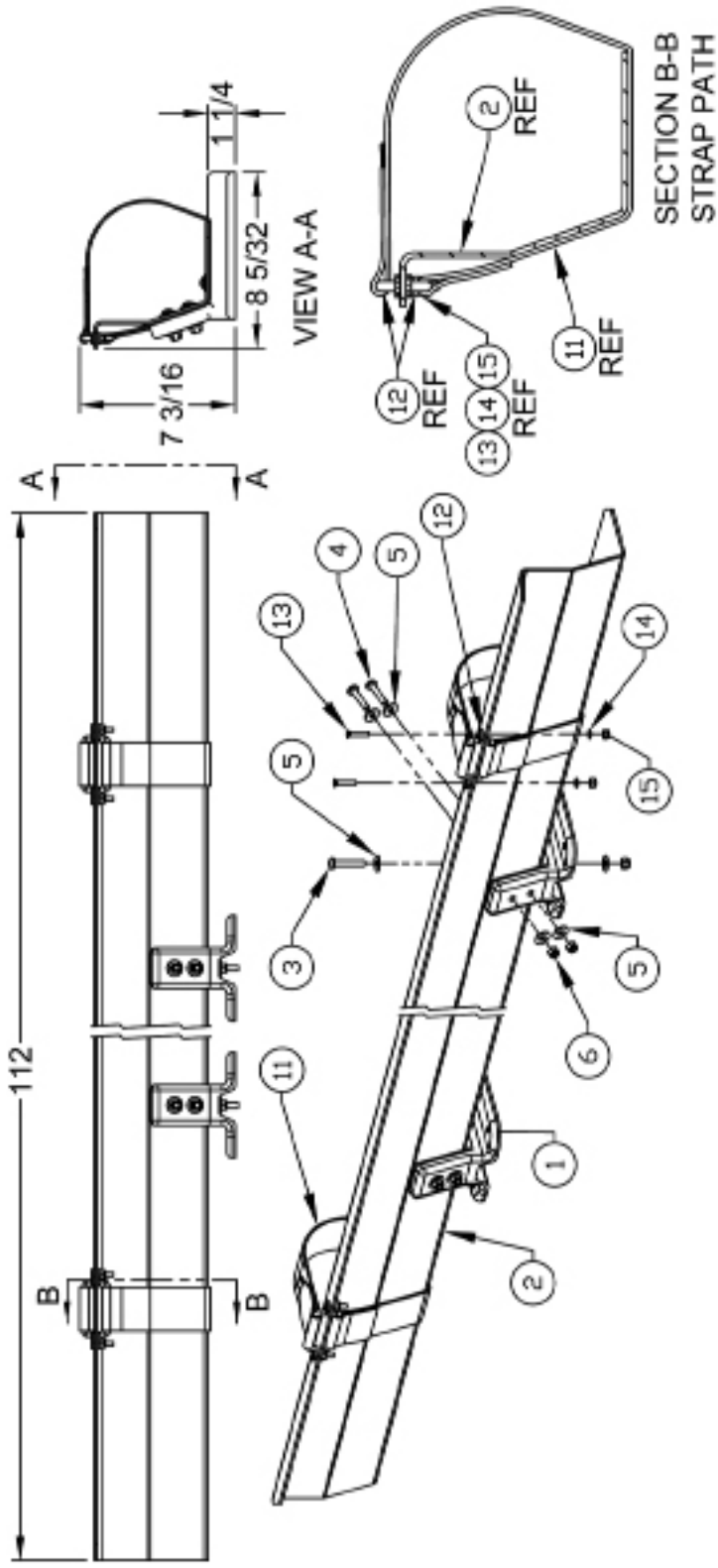

FIGURE 1
MODEL HHS-TM-1

ITEM	PART #	DESCRIPTION	QTY
1	3090-200-101	BRACKET, SINGLE HOSE TRAY	2
2	3097-155-101	TRAY, 10'	1
3	9110-222520	1/4-20 x 1 1/4 SS PAN HD PHIL	2
4	9110-222524	1/4-20 x 1 1/2 SS PAN HD PHIL	4
5	9114-112500	1/4 WASHER, FLAT	12
6	9113-172501	1/4 LOCKNUT, THIN	6
11	3099-738-105	STRAP, UMVS-1625-11 2" x 16-25"	2
12	3099-000-013	FOOTMAN'S LOOP, 2"	4
13	9110-162016	#10-32 x 1 SS FH PHIL	4
14	9114-111900	#10 WASHER, FLAT	4
15	9113-172000	#10 LOCKNUT	4

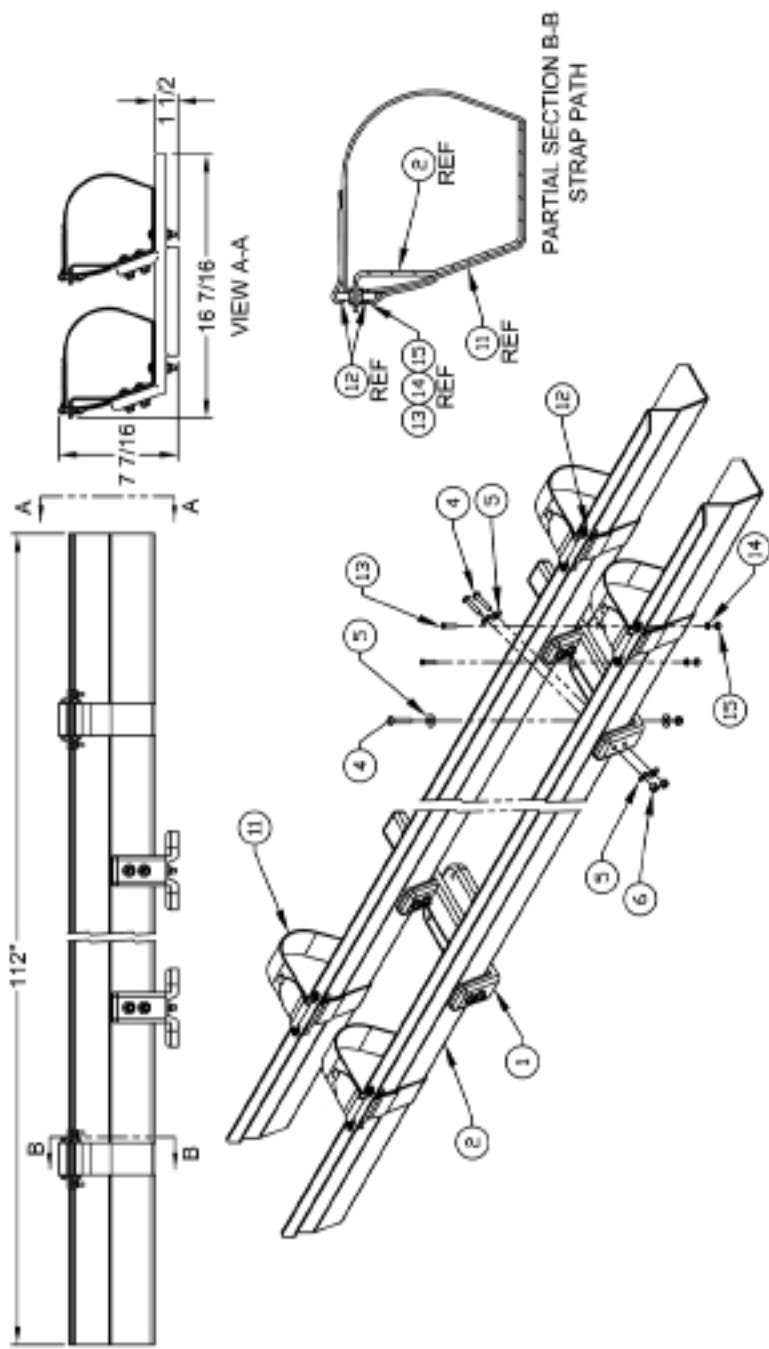

FIGURE 2
MODEL HHS-TM-2

ITEM	PART #	DESCRIPTION	QTY
1	3090-205-101	BRACKET, DOUBLE HOSE TRAY, HORIZONTAL	2
2	3097-155-101	TRAY, 10'	2
4	9110-222524	1/4-20 x 1 1/2 SS PAN HD PHIL	12
5	9114-112500	1/4 WASHER, FLAT	24
6	9113-172501	1/4 LOCKNUT, THIN	12
11	3099-738-105	STRAP, UMVS-1625-11 2" x 16-25"	4
12	3099-000-013	FOOTMAN'S LOOP, 2"	8
13	9110-162016	#10-32 x 1 SS FH P	8
14	9114-111900	#10 WASHER, FLAT	8
15	9113-172000	#10 LOCKNUT	8

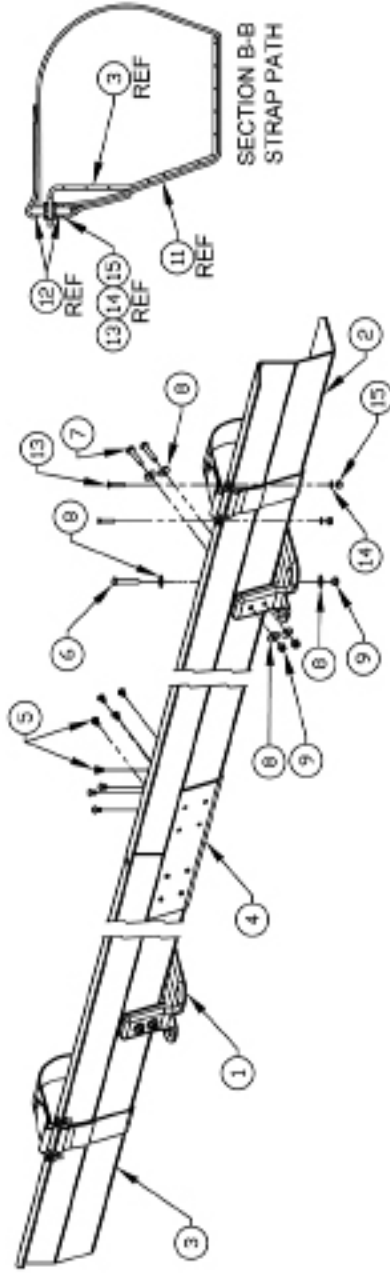
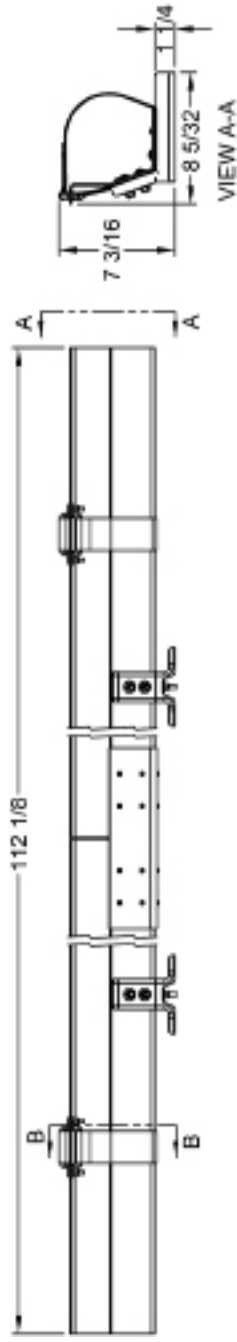

FIGURE 3
MODEL HHS-TM-1-ST

ITEM	PART #	DESCRIPTION	QTY
1	3090-200-101	BRACKET, SINGLE HOSE TRAY	2
2	3097-303-101	TRAY, 56", SPLIT RH	1
3	3097-303-103	TRAY, 56", SPLIT LH	1
4	3097-303-105	TRAY SPLICE	1
5	9110-502506	1/4-20 x 3/8 SS BUTTON HD	16
6	9110-222520	1/4-20 x 1 1/4 SS PAN HD PHIL	2
7	9110-222524	1/4-20 x 1 1/2 SS PAN HD PHIL	4
8	9114-112500	1/4 WASHER, FLAT	12
9	9113-172501	1/4 LOCKNUT, THIN	6
11	3099-738-105	STRAP, UMVS-1625-11, 2" x 16-25"	2
12	3099-000-013	FOOTMAN'S LOOP, 2"	4
13	9110-162016	#10-32 x 1 SS FH PHIL	4
14	9114-111900	#10 WASHER, FLAT	4
15	9113-172000	#10 LOCKNUT	4

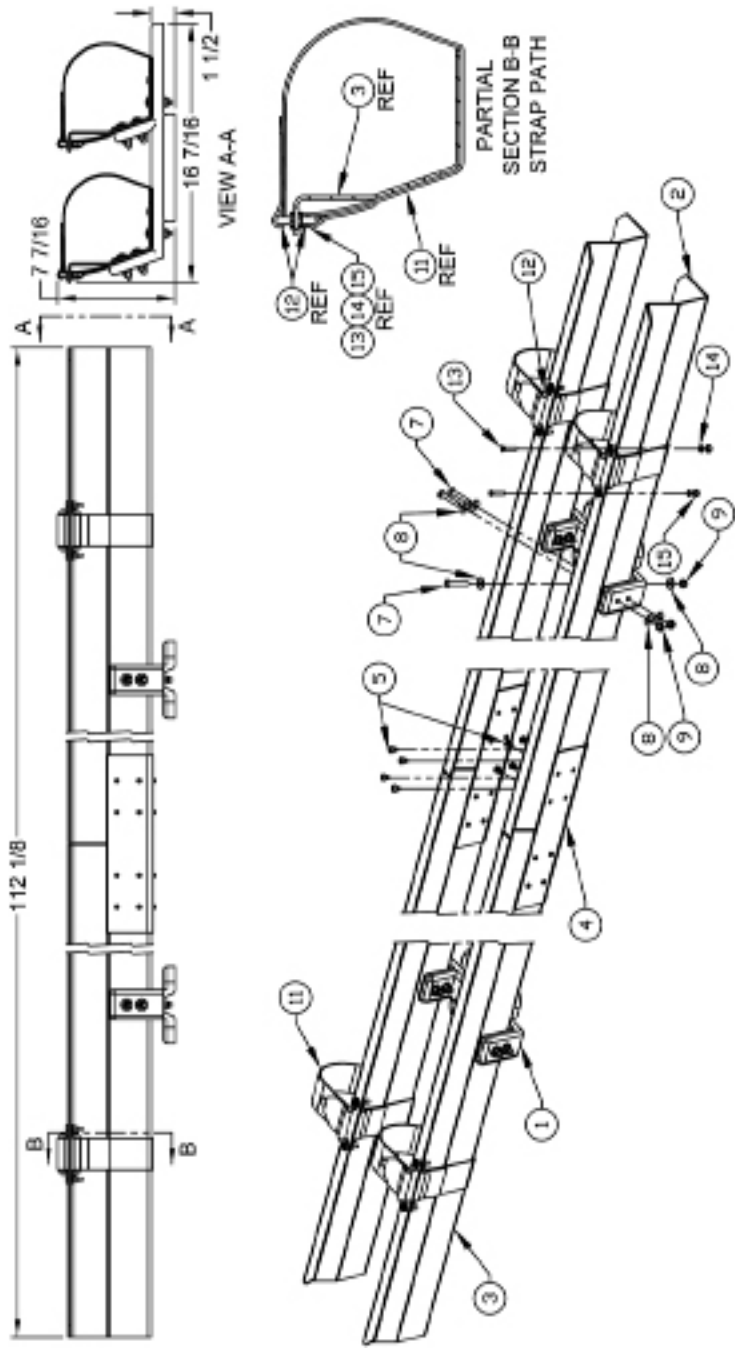

FIGURE 4
MODEL HHS-TM-2-ST

ITEM	PART #	DESCRIPTION	QTY
1	3090-205-101	BRACKET, DOUBLE HOSE TRAY, HORIZONTAL	2
2	3097-303-101	TRAY, 56", SPLIT RH	2
3	3097-303-103	TRAY, 56", SPLIT LH	2
4	3097-303-105	TRAY SPLICE	2
5	9110-502506	1/4-20 x 3/8 SS BUTTON HD	32
7	9110-222524	1/4-20 x 1 1/2 SS PAN HD PHIL	12
8	9114-112500	1/4 WASHER, FLAT	24
9	9113-172501	1/4 LOCKNUT, THIN	12
11	3099-738-105	STRAP, UMV'S-1625-11, 2" x 16-25"	4
12	3099-000-013	FOOTMAN'S LOOP, 2"	8
13	9110-162016	#10-32 x 1 SS FH PHIL	8
14	9114-111900	#10 WASHER, FLAT	8
15	9113-172000	#10 LOCKNUT	8

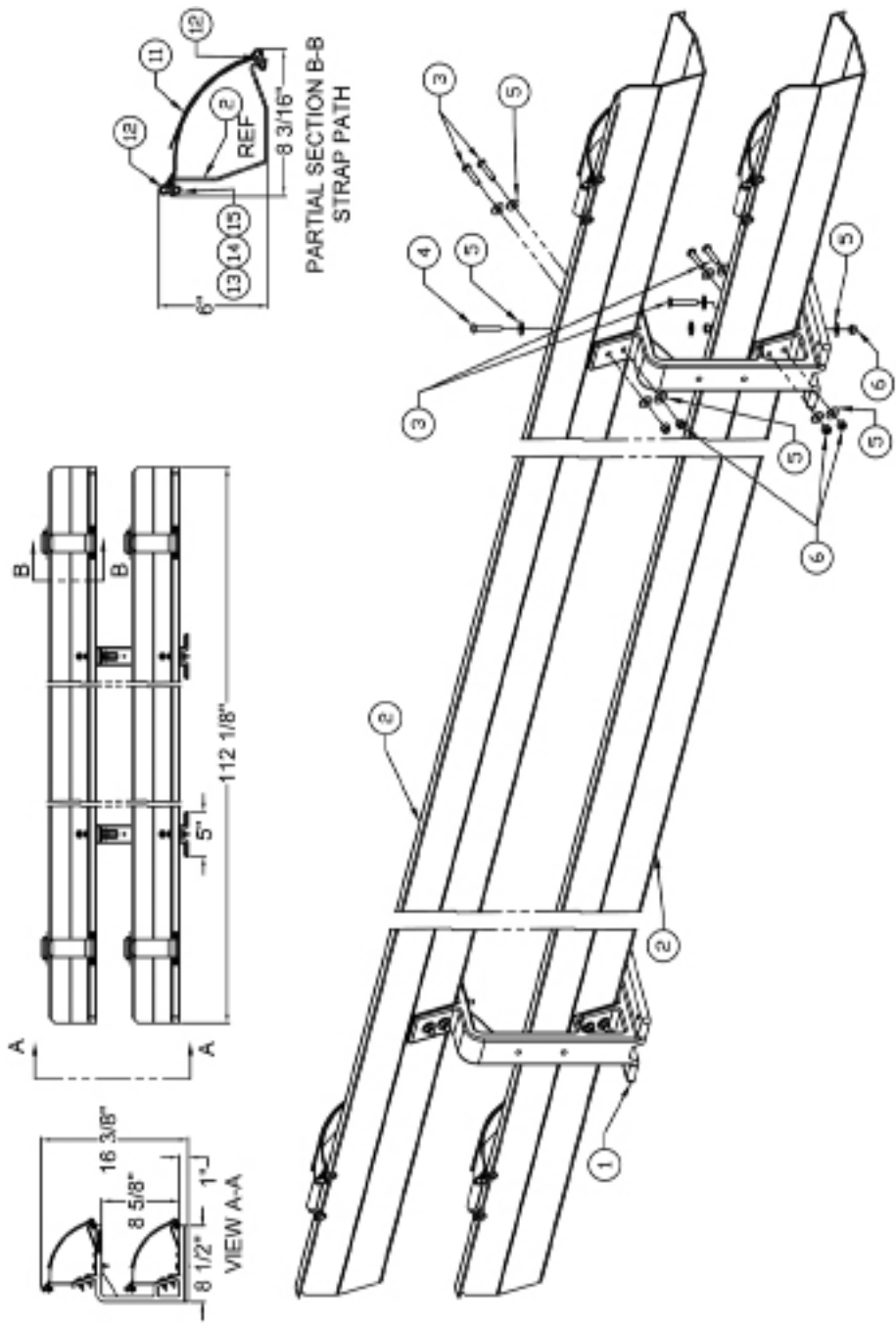

FIGURE 5
MODEL HHS-TMV-2

ITEM	PART #	DESCRIPTION I	QTY
1	3090-230-101	BRACKET, DOUBLE HOSE TRAY, VERTICAL	2
2	3097-511-107	TRAY, 10'	2
3	9110-222520	1/4-20 x 1 1/4 SS PAN HD PHIL	10
4	9110-222524	1/4-20 x 1 1/2 SS PAN HD PHIL	2
5	9114-112500	1/4 FLATWASHER, SS	24
6	9113-172501	1/4-20 LOCKNUT, THIN	12
11	3099-850-105	STRAP, SAHS-VS25-10	4
12	3099-000-013	FOOTMAN'S LOOP, 2"	8
13	9110-16200	#10-32 x 5/8 SS FH PHIL	16
14	9114-111900	#10 WASHER, FLAT	16
15	9113-172000	#10-32 LOCKNUT	16

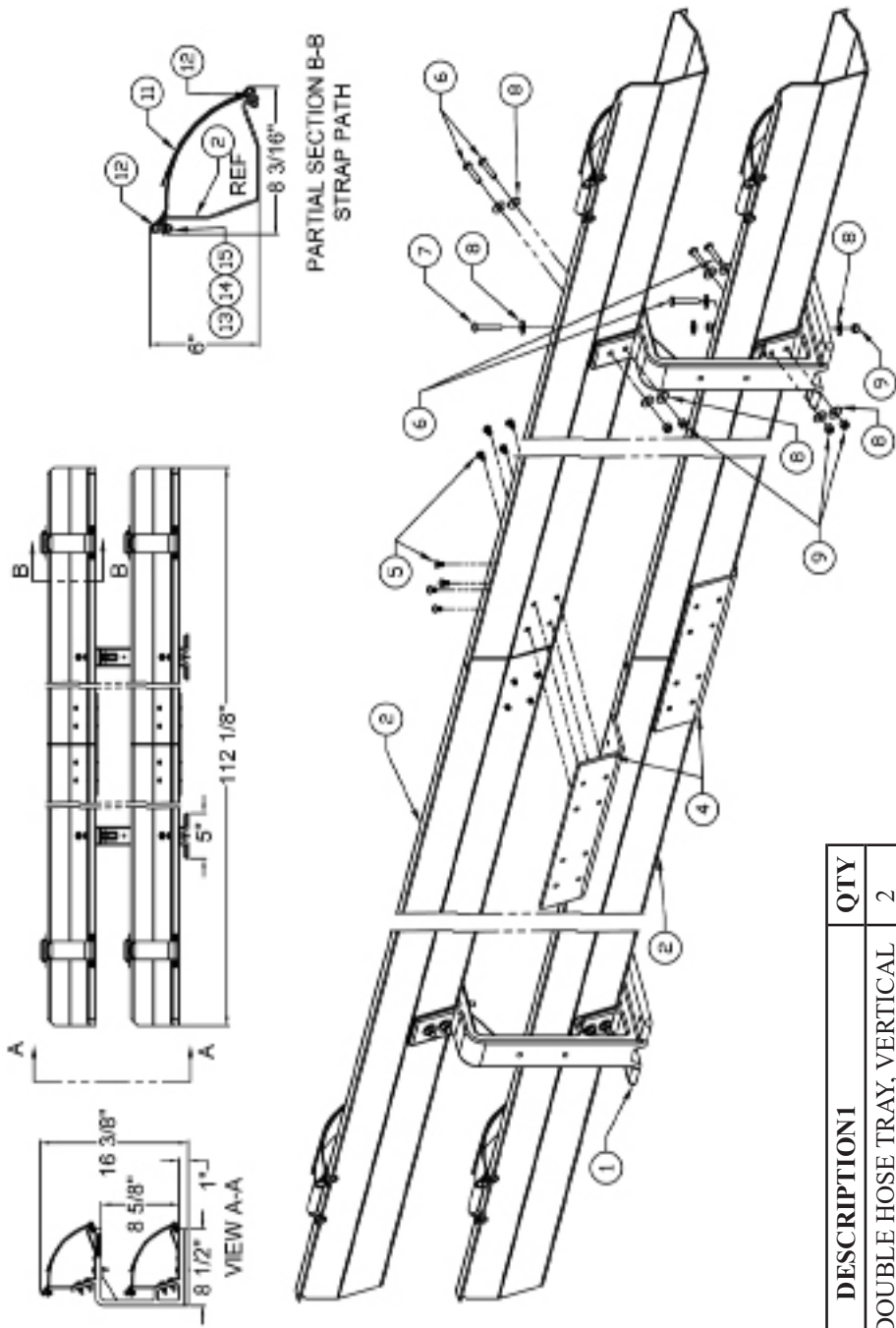

FIGURE 6
MODEL HHS-TMV-2-ST

ITEM	PART #	DESCRIPTION1	QTY
1	3090-230-101	BRACKET, DOUBLE HOSE TRAY, VERTICAL	2
2	3097-508-101	TRAY, 56" SPLIT	4
4	3097-303-105	TRAY SPLICE	2
5	9110-502506	1/4-20 x 3/8 SS BUTTON HEAD	32
6	9110-222520	1/4-20 x 1 1/4 SS PAN HD PHIL	10
7	9110-222524	1/4-20 x 1 1/2 SS PAN HD PHIL	2
8	9114-112500	1/4 FLATWASHER, SS	24
9	9113-172501	1/4-20 LOCKNUT, THIN	12
11	3099-850-105	STRAP, SAHS- VS25-10	4
12	3099-000-013	FOOTMAN'S LOOP, 2"	8
13	9110-162010	#10-32 x 5/8 SS FH PHIL	16
14	9114-111900	#10 WASHER, FLAT	16
15	9113-172000	#10-32 LOCKNUT	16

ALLOW CLEARANCE FROM THE BACK
WALL TO THE FOOTMAN'S LOOP.
THIS WILL ALLOW EASIER THREADING
OF THE STRAP THRU THE LOOP.

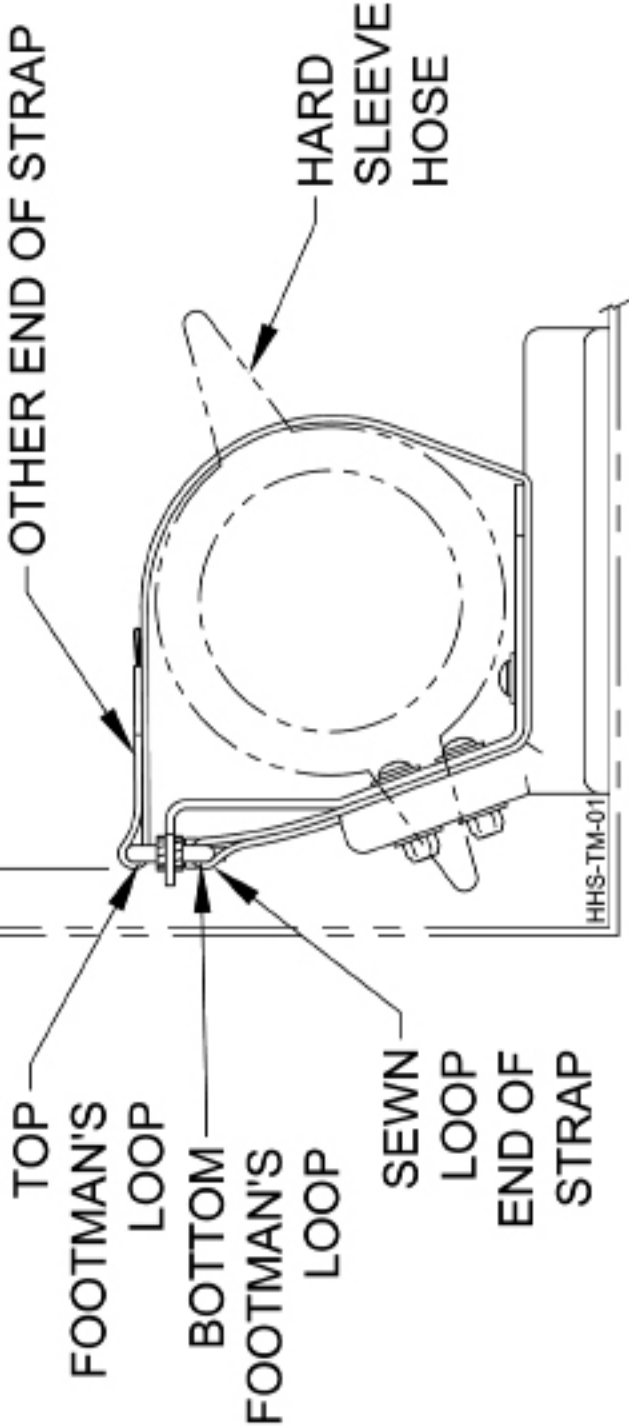

FIGURE 7

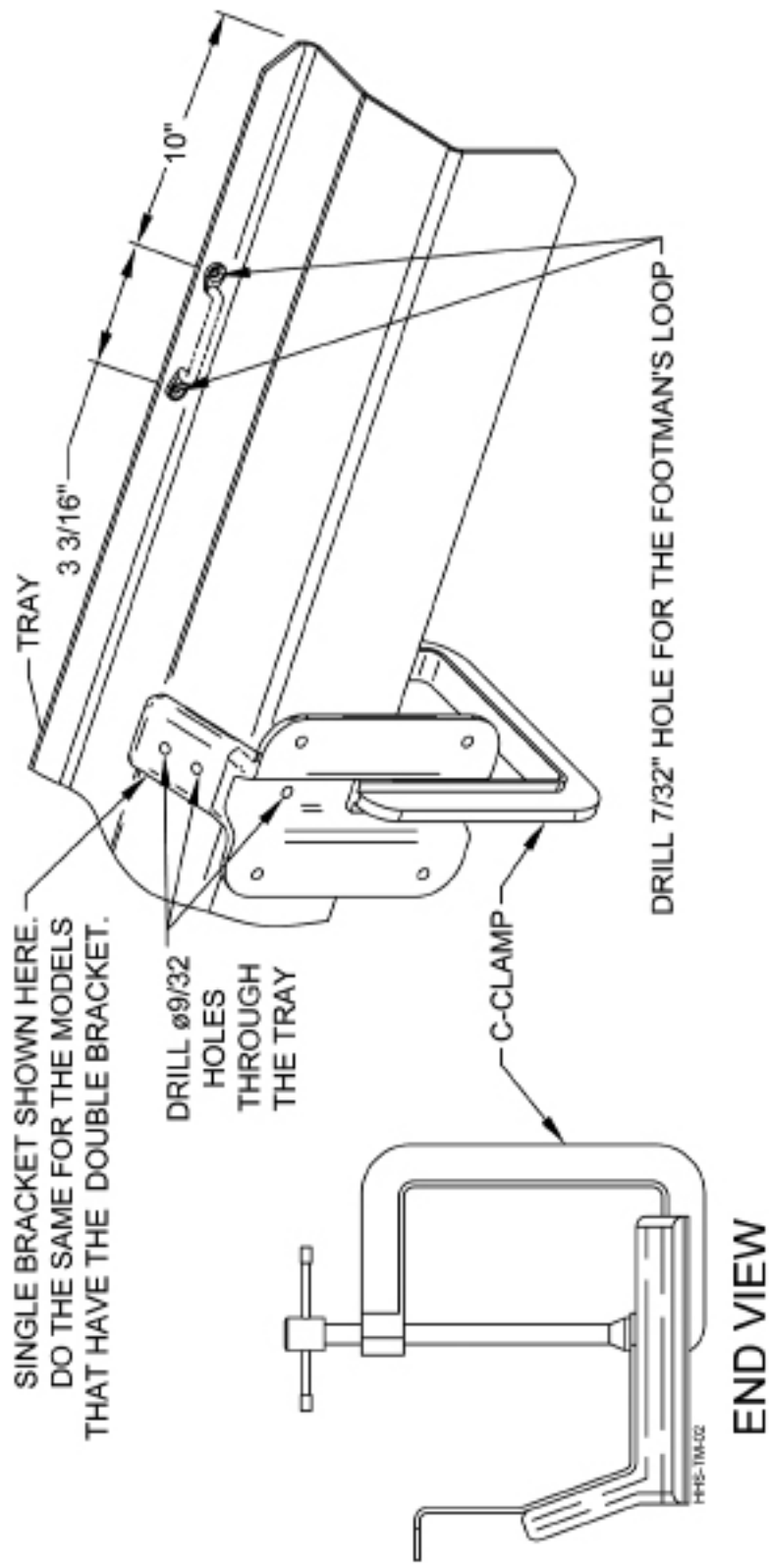

FIGURE 8

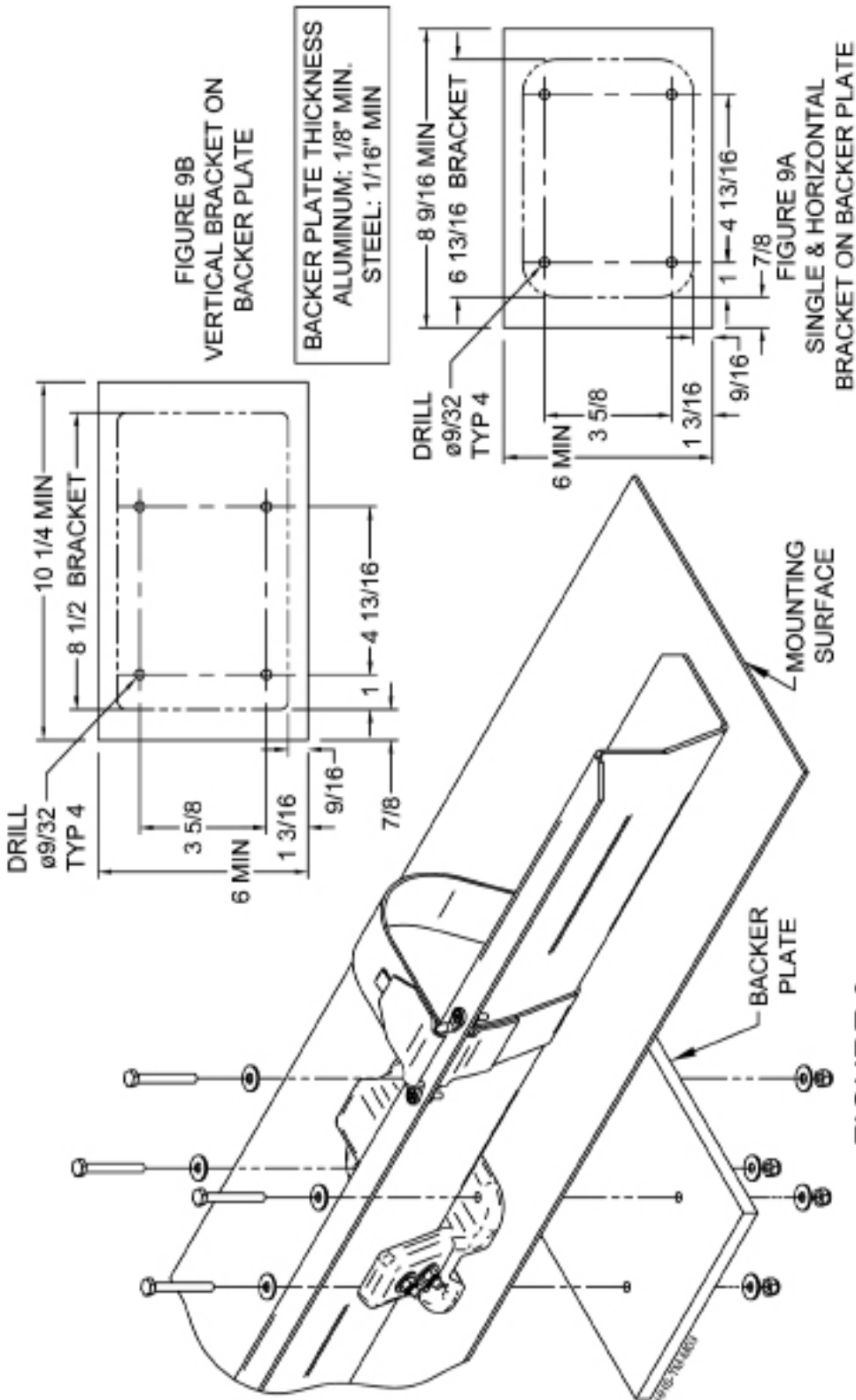

FIGURE 9



Ziamatic Corp.

10 West College Avenue, P.O. Box 337, Yardley, PA 19067-0587 • (215) 493-3618 • FAX: (215) 493-1401

*ZICO is a registered trademark for fire, safety and marine products made by Ziamatic Corp.

www.ziamatic.com

TOLL FREE: 800-711-3473

Copyright Ziamatic Corp. 9-18