

**QUIC-MOUNT® Saw Blade Post Mount - Non-Corrosive
MODEL QM-SBPM-2
PARTS AND INSTRUCTION MANUAL**

3087PM22

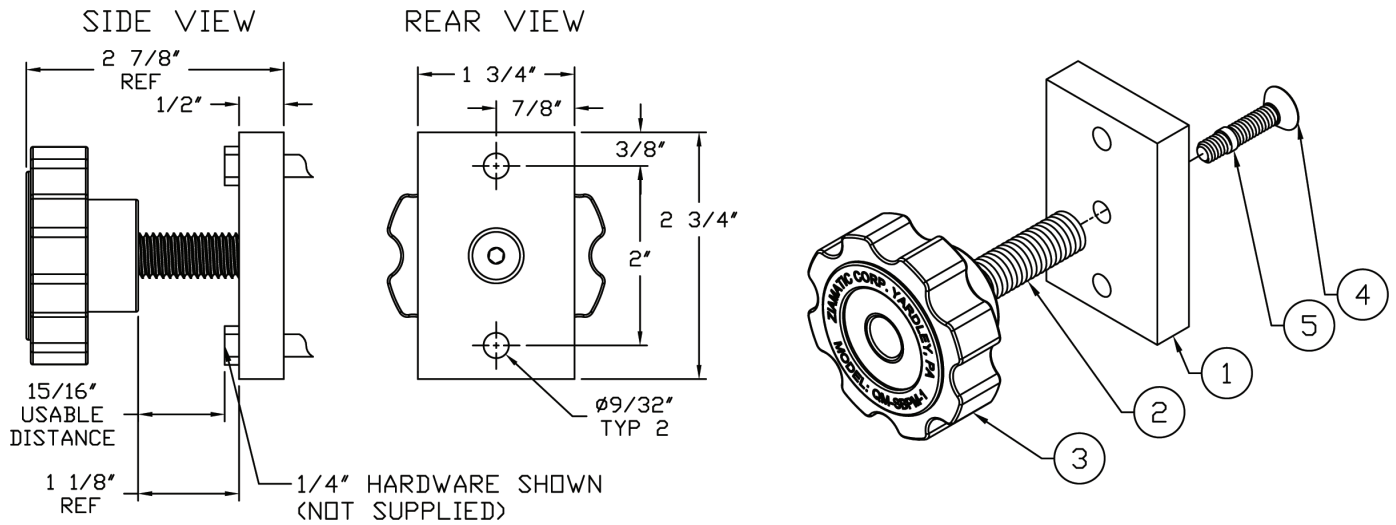

MODEL	DESCRIPTION	WT./@ IN LBS.
QM-SBPM-2	Saw Blade Post Mount - Non-Corrosive	.30

ITEM	PART NO.	DESCRIPTION	QTY.
1	3087-256-101	Base HDPE	1
2	3087-256-103	Post, ø1/2-13 Threaded Rod, SS	1
3	3087-258-111	Knob, ø1/2-13	1
4	9110-362520	Screw, 1/4 - 20 x 1-1/4 Flat Socket Cap HD, 82° SS	1
5	0000-000-122	Thread Lock, Red	1

Mounting Instructions:

1. Select a mounting location with enough clearance for the largest diameter saw blade to be easily stored and removed from the Saw Blade Post Mount assembly. Mark the center hole of the saw blade and set saw blades aside.
2. Position the Saw Blade Post Mount assembly at the marked center hole location.
3. Mount the assembly using 1/4" hardware (not supplied).

Operating Instructions:

To Stow:

1. Slide blades to be stored onto the Post (2).
2. Turn Knob (3) clockwise onto the Post and tighten against outer most blade.

To Release:

1. Turn Knob counterclockwise and remove from Post.
2. Remove blades as needed.



Ziamatic Corp.

10 West College Avenue, P.O. Box 337, Yardley, PA 19067-0587 • (215) 493-3618 • FAX: (215) 493-1401

www.ziamatic.com

TOLL FREE: 800-711-3473

*ZICO is a registered trademark for fire, safety and marine products made by Ziamatic Corp.

Copyright Ziamatic Corp. 11-21