

**ZICO®**

**QUIC-RELEASE® STRAPLESS CYLINDER BRACKET  
MODEL QR-E-1  
PARTS AND INSTRUCTION MANUAL**

**3030PM16**

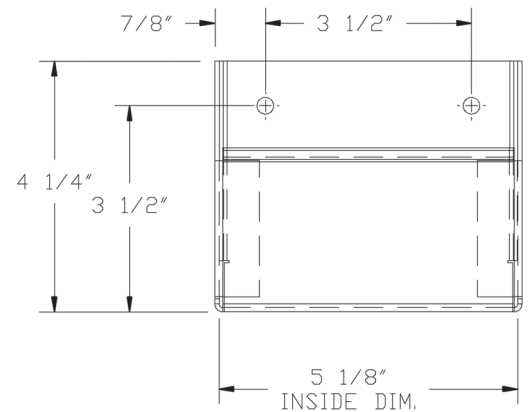
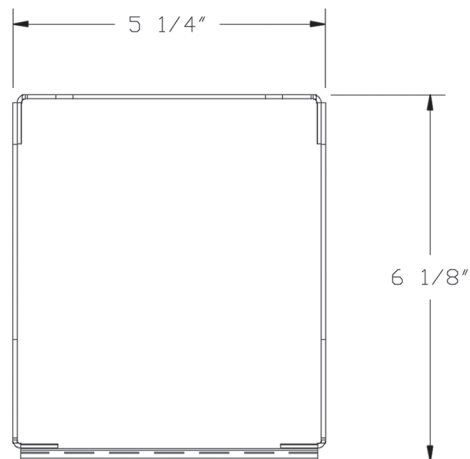
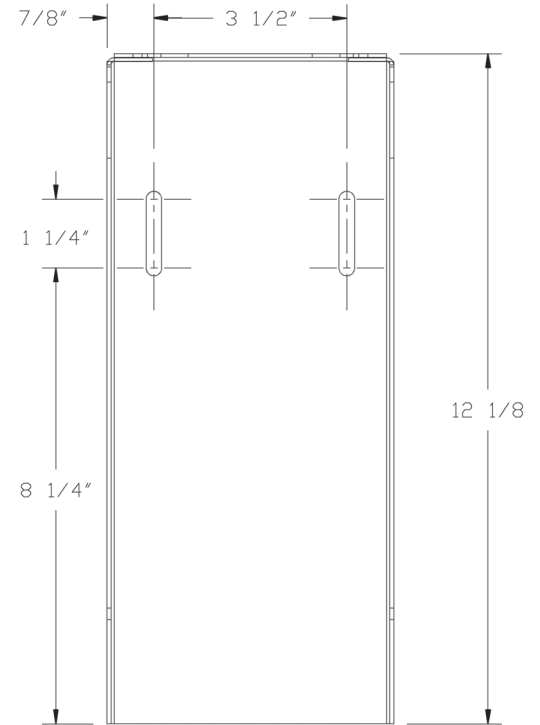
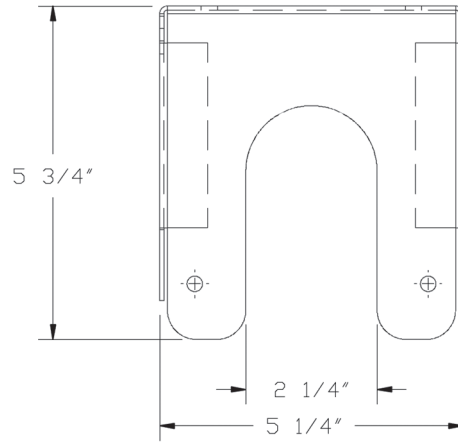

MODEL	DESCRIPTION	WT./@ IN LBS.
QR-E-1	Strapless "E" Cylinder Bracket	5.8

## Parts Diagram

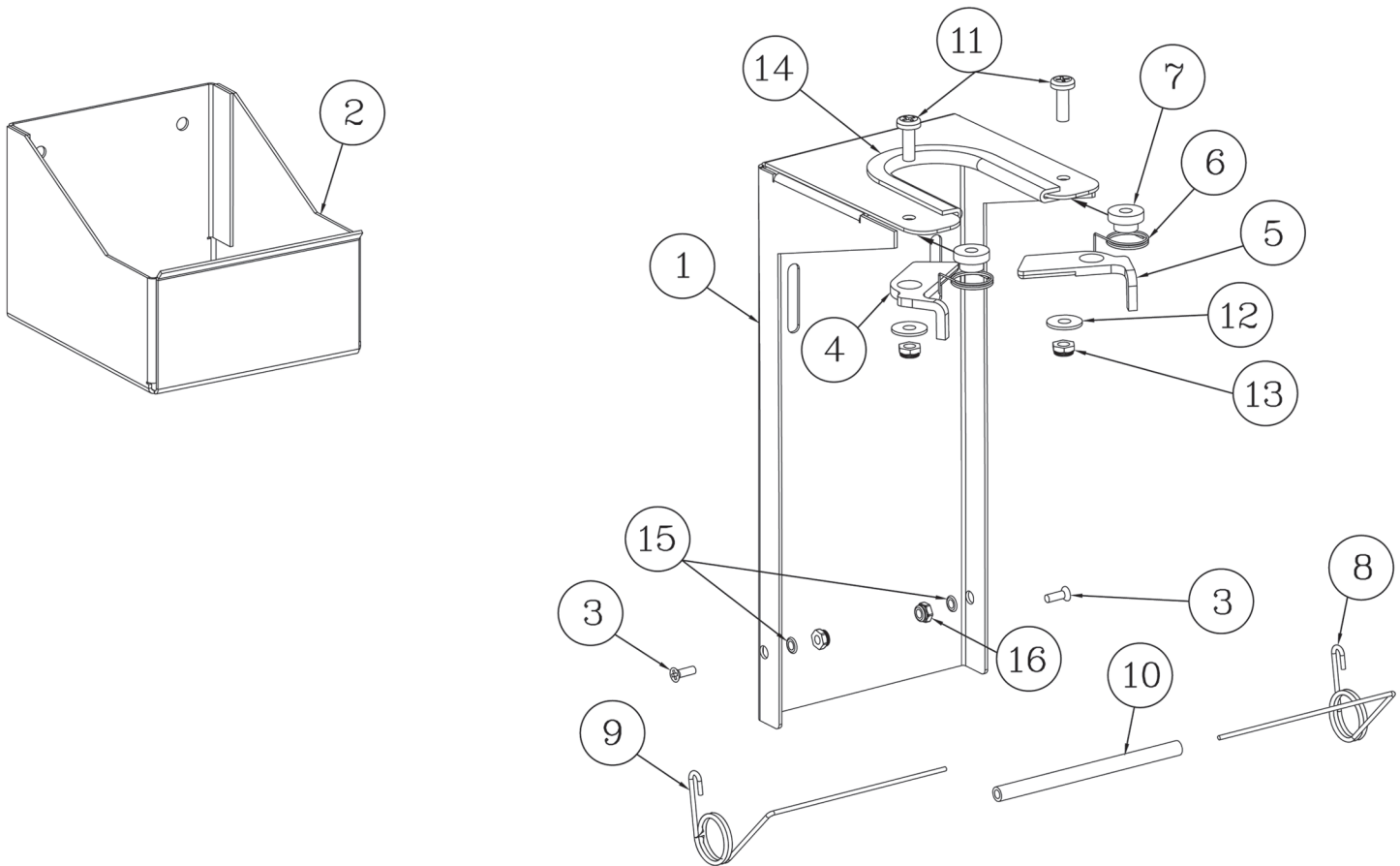

ITEM NO.	PART NO.	DESCRIPTION	QTY.
1	3030-114-103	E-CYL. BRACKET RETAINER	1
2	3030-114-101	E-CYL. BRACKET BASE	1
3	9110-361608	#8 x 1/2" FLAT HD, SOCKET HD. S.S.	2
4	3030-113-109	D-CYL. BRACKET CAM (LEFT)	1
5	3030-113-111	D-CYL. BRACKET CAM (RIGHT)	1
6	3030-113-113	D-CYL. BRACKET CAM SPRING	2
7	3030-113-115	D-CYL. BRACKET CAM SPACER	2
8	3030-113-117	D-CYL. BRACKET RETURN SPRING RH	1
9	3030-113-119	D-CYL. BRACKET RETURN SPRING LH	1
10	3030-113-121	D-CYL. BRACKET SPRING JACKET	1
11	9110-352512	BUTTON HD CAP, 1/4"-20 x 3/4 S.S.	2
12	9114-112500	WASHER, 1/4" FLAT S.S.	2
13	9113-172500	LOW PRO. NUT, 1/4-20, NYLOCK S.S.	2
14	3030-113-123	VINYL EDGE GUARD	1
15	9114-111600	#8 FLAT WASHER	2
16	9113-191700	LOW PRO. NUT, #8, NYLOCK S.S.	2

## Operating Instructions

---

### To store standard and steel "E" cylinders:

1. Place cylinder into bracket bottom-first, onto the E-Cyl. Bracket Base (2).
2. Press cylinder through the latches (4 & 5), until both click into the locked position.
3. Check that the cylinder is now secure against the latches.

### To remove cylinders:

1. Slightly press cylinder against the D-Cyl. Bracket Return Spring Assembly (8 & 9) to relieve pressure on the latch.
2. Squeeze latch handles inward, toward each other, to disengage the latches.
3. Allow D-Cyl. Bracket Return Spring Assembly to push the cylinder free of the latches.

## Mounting Instructions

---

- Mount vertically.
- Brackets may be mounted side by side.
- Minimum of 3 mounting points using 1/4" screws.
- Mounting surface must be able to withstand a pull-out force exceeding strength of screws.



*Ziamatic Corp.*

10 West College Avenue, P.O. Box 337, Yardley, PA 19067-0587 • (215) 493-3618 • FAX: (215) 493-1401

\*ZICO is a registered trademark for fire, safety and marine products made by Ziamatic Corp.

[www.ziamatic.com](http://www.ziamatic.com)

TOLL FREE: 800-711-3473

Copyright Ziamatic Corp. 4-12