

**QUIC-LOCK® MECHANICAL BRACKET  
MODEL QLM-U  
PARTS AND INSTRUCTION MANUAL**

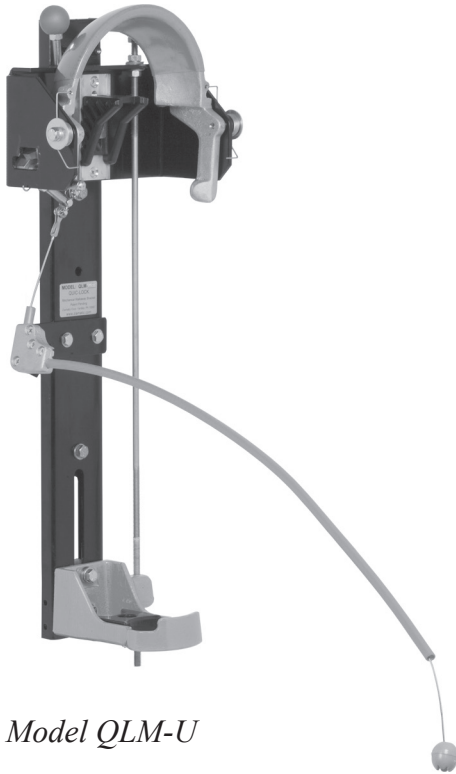

*Model QLM-U*

**The QUIC-LOCK is an easily adjustable mechanical SCBA bracket that is NFPA 1901-09 compliant.** Third party tested to 10G.

The Quic-Lock mechanical WALKAWAY bracket holds the SCBA without the need of straps or other devices. **It is fully adjustable to fit most SCBAs with only minor adjustments.** The bracket holds the SCBA by the ends using the adjustable footplate, and a top clamp to secure it.

Donning the SCBA is fast and easy. The firefighter simply slips into the harness, pulls on the release cord, and is ready to go. Storing the SCBA is done by placing the valve on the footplate and pulling down the top clamp and up on the locking rod.

The backplate is made of steel to provide a strong backbone to the bracket. Both the backplate and cast aluminum footplate are powder coated to provide years of trouble free service. The top clamp is PVC coated to prevent damage to the cylinder while in use.

**WARNING: Bracket and SCBA harness are not to be used in place of a seat belt.**



*Model QLM-U-OPR*

The Quic-Lock Mechanical WALKAWAY Bracket will accommodate the optional pull release, model QLM-U-OR. To order the Quic-Lock with the optional pull release already attached, order QLM-U-OPR.

<b>MODEL</b>	<b>DESCRIPTION</b>	<b>WT./@ IN LBS.</b>
QLM-U	Quic-Lock Mechanical Bracket	14.0
QLM-U-OPR	Quic-Lock Mechanical Bracket with Optional Pull Release	14.1
QLM-U-OR	Optional Pull Release for the Quic-Lock	0.6

# Parts Diagram - QUIC-LOCK - Model QLM-U

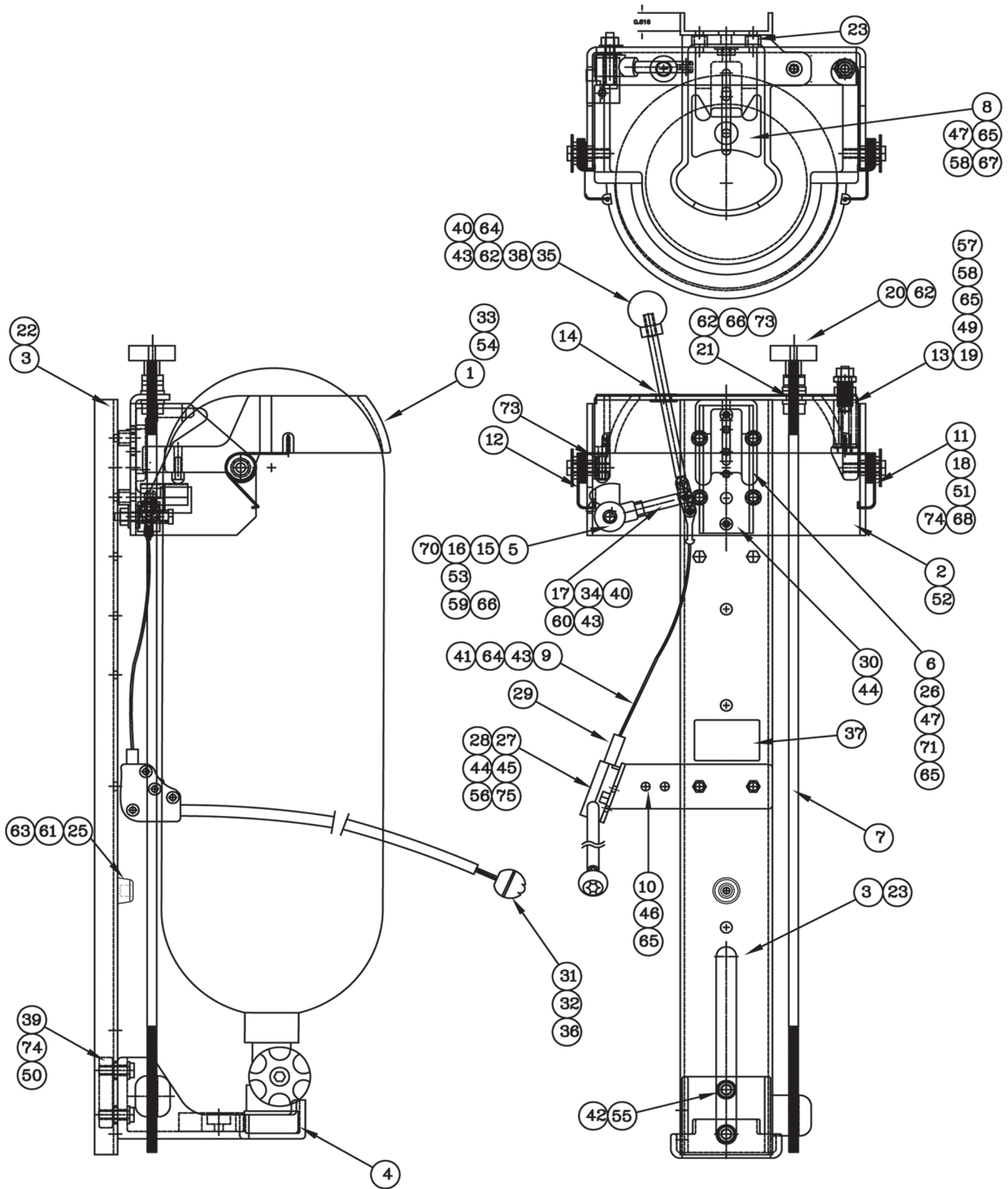

# Parts Breakdown - QUIC-LOCK - Model QLM-U

ITEM NO.	PART NO.	DESCRIPTION	QTY.
1	1045-320-101	Top Clamp	1
2	1045-320-103	Upper Bracket	1
3	1045-320-105	Backplate	1
4	1045-320-107	Footplate	1
5	1045-320-109	Cam	1
6	1045-320-111	Cyl. Locator/Bumper	1
7	1045-320-113	Adjustment Rod, Footplate	1
8	1045-320-115	Adjustment Block, Footplate	1
9	1045-320-117	Cable Assembly, Pull Release	1
10	1045-320-135	Bracket, Release Assy.	1
11	1045-320-119	Counter Spring, Top Clamp, LH	1
12	1045-320-121	Counter Spring, Top Clamp, RH	1
13	1045-320-123	Spring, Breakaway	1
14	1045-320-167	Brass Grommet	1
15	1045-320-125	Spring, Cam Return	1
16	1045-320-127	Sleeve, Cam Pivot, 1/2OD x 14 GA. x 1.125 LG	1
17	1045-320-129	Cam Handle	1
18	1045-320-131	Spacer, Top Clamp Pivot	2
19	1045-320-187	Adjust Screw, Breakaway Spring	1
20	1045-320-175	Knob, Footplate Adjustment	1
21	1045-320-137	Spacer, Adj. Rod, 1/2OD x 14 GA. (.083) x .281LG STL.	1
22	1045-320-139	Spacer, 3/8 Sched 80 Alum., 675OD x .423ID x .625LG.	2
23	1045-320-189	Nut Inserts, 1/4-20 ZPZ	8
25	1090-000-150	Rubber Bumper	1
26	1045-320-143	Backup Plate, Bumper	1
27	1045-340-101	Elbow, Hex Side	1
28	1045-340-103	Elbow, C'Sink Side	1
29	1045-340-107	Plastic Tubing	1
30	1045-320-183	Spacer/Locator, Bumper	1
31	1045-320-169	Pull Release Knob	1
32	1045-320-185	Stop Sleeve	1
33	1045-320-171	Spacer, 7/16OD x 12GA. (.109) STL. DWG. 1045 320-127	1
34	1045-320-145	Cam Handle Link Plate	1
35	1045-320-149	Cam Release Push Rod	1
36	9010-391603	Setscrew, #8-32x3/16 Flat Point	1
37	1045-320-177	Label, Model #	1

ITEM NO.	PART NO.	DESCRIPTION	QTY.
38	1045-320-176	Knob, Cam Lock Red, 1 1/4	1
39	1029-105-127	Footplate Mounting Block	1
40	9070-000608	Cotter Pin, 1/16 x 1/2, ZPS	2
41	9082-001209	Hairpin Cotter	1
42	1045-320-199	Footplate Mounting Spacer	2
43	9080-001808	Clevis Pin, 3/16ø x 1/2" LG.	3
44	9010-162010	Screw, 10-32 x 5/8" LG	4
45	9010-162016	Screw, 10-32 x 1" LG	2
46	9015-102512	Screw, 1/4-20 x 3/4 HH	2
47	9010-562516	Screw, 1/4-20 x 1" RDHD Torx, Bumper Mount	2
49	9015-102544	Screw, 1/4-20 x 2 3/4" HH	1
50	9018-103116	Screw, 5/16-18 x 1" HH, GR 8	2
51	9015-103120	Screw, 5/16-18 x 1 1/4 HH	2
52	9010-462516	Screw, 1/4-20 x 1 FH, Torx	4
53	9015-103128	Screw, 5/16-18 x 1 3/4	1
54	9020-102116	Drive Screw, #12 x 1" LG.	1
55	1045-320-197	Footplate Spacer Sleeve	2
56	9012-102000	Jam Nut, 10-32, 1/8 HT, SZP	4
57	9012-155005	Jam Nut, 1/2-20 Thin, ZPS	1
58	9015-172500	Nut, 1/4-20, Self Lock	2
59	9015-173100	Nut, 5/16-18, Hex, Self Loc	1
60	9015-113700	Nut, 3/8-16 Hex, Plain	1
61	9010-222012	Screw, 10-32 x 3/4 PH SS Phil	1
62	9015-113100	Nut, 5/16-18, Hex, Plain	4
63	9013-252000	Nut, 10-32 Hex, Nylon Lock	1
64	9014-111900	Plainwasher, #10 SZO	2
65	9114-112500	Plainwasher, 1/4ø SS	3
66	9114-113100	Plainwasher, 5/16ø SS	4
67	9014-132500	Washer, 1/4ø, GR8, .1/16 Thk.	1
68	9014-163100	Bar Washer, 5/16 NOM. x 1 1/4x 1/16 SZP	2
70	9114-105000	Washer, 1/2ID x 7/8OD x 1/16 Thk., SS	1
71	9014-202500	Lockwasher, 1/4ø Split	1
73	3097-105-130	Washer, Plastic, 1/2ID x 3/4OD x .062	2
74	9014-203100	Lockwasher, 5/16øNOM., Split	4
75	9014-251900	Lockwasher, Intrnal Tooh, #10 SZP	4

# Parts Diagram & Breakdown - QUIC-LOCK - Model QLM-U-OR

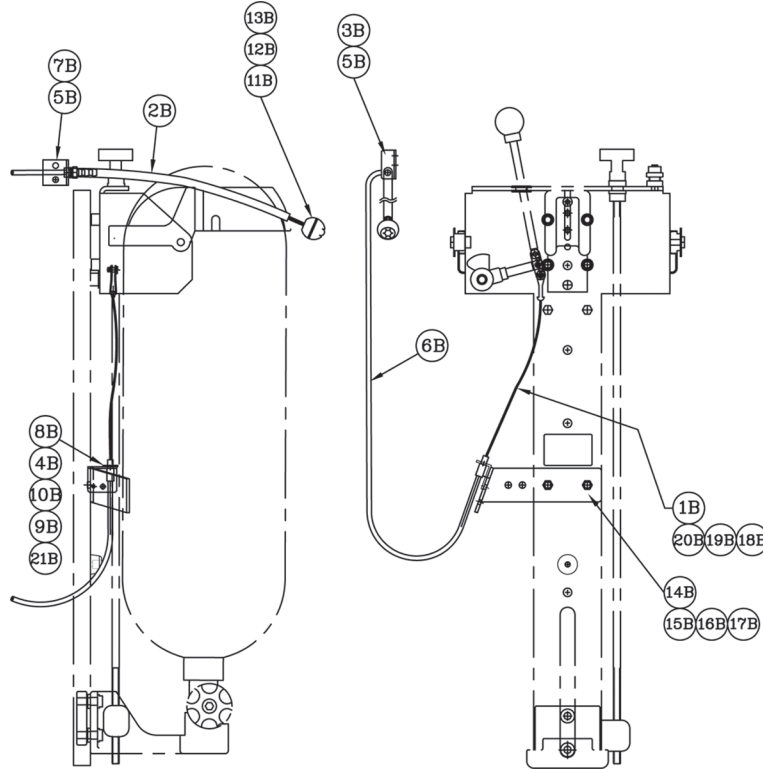

ITEM	PART NO.	DESCRIPTION	QTY.
1B	1045-321-101	Release Cable Assembly	1
2B	1027-105-131	Yellow Tubing 10"	1
3B	1010-175-131	Barbed Fitting	1
4B	1027-105-135	Pull Release Bracket, Upper	1
5B	1027-105-125	Pull Release Bracket, Release End	1
6B	1027-105-129	Conduit with Crimped Fitting	1
7B	9025-172006	10-32 Screw, Hex Hd	2
8B	1027-105-137	Push Nut	1
9B	9010-222012	10-32 Nut, Nylon Lock	1
10B	9020-101-305	#6 x 5/16" Drive Screw	1
11B	1045-320-169	Pull Release Knob	1
12B	1045-320-185	Stop Sleeve	1
13B	9010-391603	#8-32 x 3/16" Set Screw	1
14B	1045-320-135	Release Bracket	1
15B	9015-102512	1/4-20 x 3/4" Screw	2
16B	9114-112500	1/4" Plainwasher	2
17B	9014-202500	1/4" Lockwasher, Split	2
18B	9082-001209	Hairpin Cotter	1
19B	9014-111900	#10 Plainwasher	1
20B	9080-001808	3/16" x 1/2" Clevis Pin	1
21B	9010-222010	10-32 x 5/8" Screw	1

# Parts Terminology - QUIC-LOCK - Model QLM-U

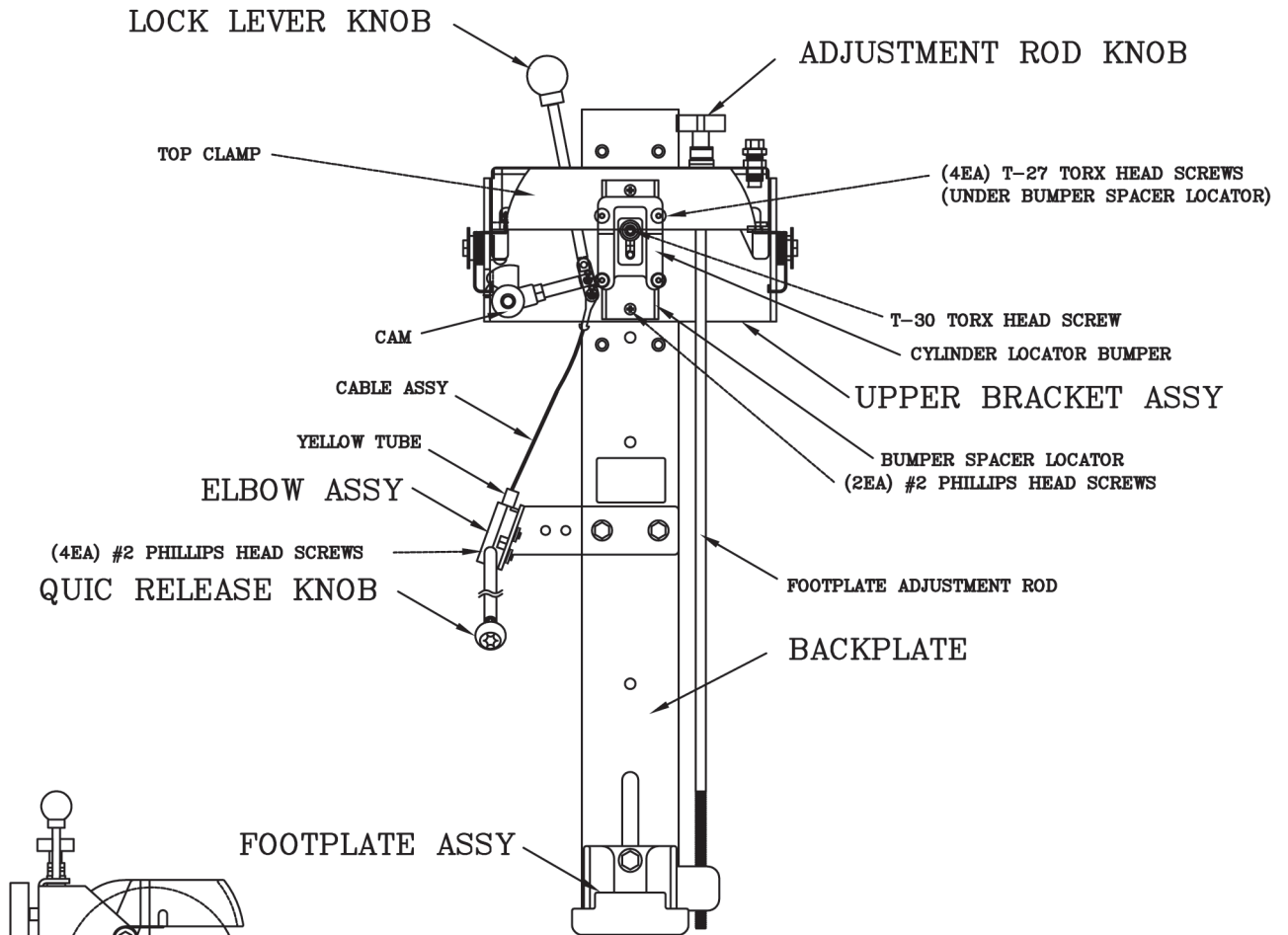

FRONT VIEW OF QLM-U

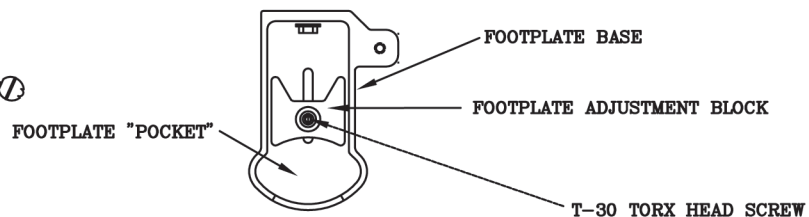
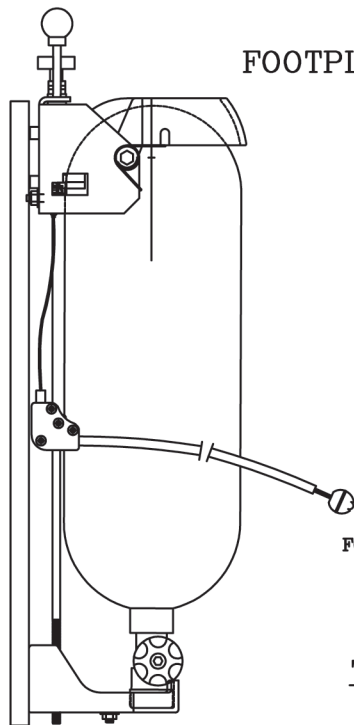

TOP VIEW OF QLM-U FOOTPLATE ASSY

# MSA SCBA Warning

---

**If using the Quic-Lock with an MSA SCBA cylinder, you must read this important information:**

## **TO SAFELY SECURE YOUR MSA SCBA**

If your MSA SCBA cylinder uses a gauge guard with the approximate dimensions shown in Ref. A, you must use the included adapter plate as shown in Ref. B, secured to the inside of the Footplate as shown.

If your MSA SCBA cylinder has a smaller gauge guard, this adapter should not be used. Damage may result when using the adapter with a smaller gauge guard.

Ref. A

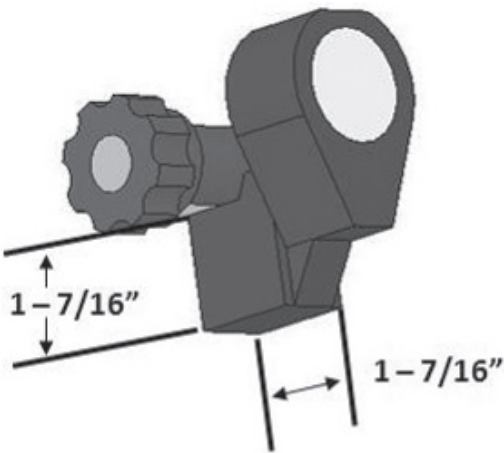

Ref. B

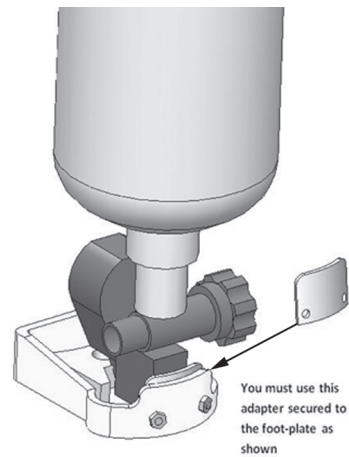

# Set-Up Instructions - QUIC-LOCK

---

1. Loosen the T-30 torx head screw holding the Footplate Adjustment Block to the Footplate just enough so that the Adjustment Block can slide back and forth on the Footplate. If you are using an MSA cylinder, the Adjustment Block will need to be rotated 180° and the MSA footplate extension may need to be installed (see Page 6).
2. Place the bottom of your SCBA Air Cylinder Valve in the Footplate Assembly. While keeping the Air Cylinder Valve Assembly as far forward as it will go in the Footplate "pocket", slide the Adjustment Block so there is approximately 3/8" clearance between the Adjustment Block and the bottom of the Air Cylinder Valve.
3. Remove the SCBA Air Cylinder from the Footplate and re-tighten the T-30 torx head screw holding the Footplate Adjustment Block.
4. Determine the most accommodating position for your Upper Bracket Assembly using the information from the chart on pages 8-9 and the diagram on page 10. If your Quic-Lock was not pre-set for your specific SCBA prior to shipping, it will come standard in the "B" position. If your SCBA is currently in the correct position, skip to Step 11.
5. If you need to adjust the Upper Bracket Assembly to a different position, loosen the T-30 torx head screw holding the Cylinder Locator Bumper and slide the Cylinder Locator Bumper to a position that gives access to both #2 phillips head screws on the Bumper Spacer Locator. (See Figure 1, page 11.) Remove the two screws, and set the Bumper Spacer Locator & Cylinder Locator Bumper aside. (See Figure 2 & 3, page 11.)
6. Remove the (4) T-27 torx head screws that are holding the Upper Bracket Assembly in place.
7. Turn the Footplate Adjustment Rod Knob to allow the Upper Bracket Assembly to line up to the desired mounting location. Be careful not to bend the Footplate Adjustment Rod.
8. If moving the Upper Bracket Assembly higher, loosen (4) #2 phillips head screws on the Elbow Assembly and slide the Yellow Tube up 2 inches further past the Elbow Assembly. Re-tighten the (4) #2 phillips head screws on the Elbow Assembly after the Yellow Tube has been repositioned. (See Figure 4, page 11.)
9. Reattach the Upper Bracket Assembly in the new position using the (4) T-27 torx screws.
10. Reattach the Bumper Spacer Locator to the Upper Bracket Assembly with the (2) #2 phillips head screws.
11. Tighten or loosen the T30 torx head screw holding the Cylinder Locator Bumper so that it may slide up and down on the Bumper Spacer Locator. Make sure the Cam Release Knob is in the "down" position.
12. Place the SCBA Air Cylinder Valve in the Footplate and hold the SCBA upright while pulling down the Top Clamp to hold the top of the Air Cylinder.
13. Adjust the Footplate height using the Footplate Adjustment Rod Knob until there is approximately a 1/4" gap between the top of the Air Cylinder and the top of the Top Clamp.
14. Slide the Cylinder Locator Bumper up or down until it touches the Air Cylinder and keeps it held firmly toward the front of the Top Clamp. Remove the Air Cylinder and tighten the T-30 torx head screw on the Cylinder Locator Bumper.
15. If the Air Cylinder cannot be held firmly against the front of the Top Clamp by the Cylinder Locator Bumper, it may be necessary to change the location of the T-30 torx head screw holding the Cylinder Locator Bumper to one of the different positions (1, 2, 3 or 4) in order to get the correct fit described in step 17.
16. Place the SCBA into the bracket and pull the Lock Lever Knob "up" firmly to lock the SCBA in place. The SCBA should be held firmly in place. If it is not, repeat steps 12-16 and fine-tune until you get a satisfactory final adjustment (see Page 12).

## SCBA Reference Chart

SCBA MODEL	CYLINDER SIZE	UPPER BRACKET LOCATION	BUMPER LOCATION	BUMPER POSITION
Drager Air Boss Evolution PSS 100	30 Min 4500 PSI	B	2	L
Drager Air Boss Evolution PSS 100	45 Min 4500 PSI	B	2	S
Drager Air Boss Evolution PSS 100	60 Min 4500 PSI	B	2	S
Drager Air Boss Evolution	30 Min 4500 PSI	B	3	L
Drager Air Boss Evolution	45 Min 4500 PSI	B	2	S
Drager Air Boss Evolution	60 Min 4500 PSI	A	1	S
Global Safety Pioneer	30 Min 4500 PSI	B	3	L
Global Safety Pioneer	45 Min 4500 PSI	B	2	S
Global Safety Pioneer	60 Min 4500 PSI	A	2	S
Interspiro Spiromatic S4	30 Min 4500 PSI	B	2	L
Interspiro Spiromatic S4	45 Min 4500 PSI	A	2	S
Inerspiro Spiromatic S4	60 Min 4500 PSI	A	2	S
ISI Viking DXL	30 Min 4500 PSI	A	3	L
ISI Viking DXL	45 Min 4500 PSI	B	2	S
ISI Viking DXL	60 Min 4500 PSI	A	2	S
ISI Viking Z-7	30 Min 4500 PSI	A	3	L
ISI Viking Z-7	30 Min 2216 PSI	B	2	S
ISI Viking Z-7	45 Min 4500 PSI	B	2	S
ISI Viking Z-7	60 Min 4500 PSI	A	3	L
MSA Firehawk	30 Min 4500 PSI	B	2	L
MSA Firehawk	30 Min 3000 PSI	A	2	L
MSA Firehawk	45 Min 4500 PSI	B	2	S
MSA Firehawk	45 Min 4500 PSI Low Pro	A	2	S
MSA Firehawk	60 Min 4500 PSI	A	2	S
MSA Firehawk M-7	30 Min 4500 PSI	B	2	L
MSA Firehawk M-7	30 Min 3000 PSI	A	2	S
MSA Firehawk M-7	30 Min 2216 PSI	B	2	S
MSA Firehawk M-7	45 Min 4500 PSI	B	2	S
MSA Firehawk M-7	45 Min 4500 PSI Low Pro	A	2	S
MSA Firehawk M-7	60 Min 4500 PSI	A	2	S
MSA Stealth	30 Min 4500 PSI	B	2	L
MSA Stealth	30 Min 4500 PSI	B	2	S
MSA Stealth	30 Min 3000 PSI	A	2	S
MSA Stealth	45 MIN 4500 PSI	B	2	S
MSA Stealth	60 Min 4500 PSI	A	2	S



## SCBA Reference Chart

SCBA MODEL	CYLINDER SIZE	UPPER BRACKET LOCATION	BUMPER LOCATION	BUMPER POSITION
Scott AP50	30 Min 4500 PSI	B	3	L
Scott AP-50	30 Min 2216 PSI	A	2	S
Scott AP-50	45 Min 4500 PSI Low Pro	A	2	S
Scott AP-50	45 Min 4500 PSI	B	3	S
Scott AP-50	60 Min 4500 PSI	A	2	S
Scott AP-75	30 Min 4500 PSI	B	3	L
Scott AP-75	30 Min 2216 PSI	A	2	S
Scott AP-75	45 Min 4500 PSI Low Pro	B	3	S
Scott AP-75	45 Min 4500 PSI	A	2	S
Scott AP-75	60 Min 4500 PSI	A	2	S
Scott NXG2	30 Min 4500 PSI	B	3	L
Scott NXG2	30 Min 2216 PSI	A	2	S
Scott NXG2	45 Min 4500 PSI Low Pro	A	3	S
Scott NXG2	45 Min 4500 PSI	B	2	S
Scott NXG2	60 Min 4500 PSI Kevlar	A	2	S
Scott NXG2	60 Min 4500 PSI	A	1	S
Scott NXG7	30 Min 4500 PSI	B	3	L
Scott NXG7	30 Min 2216 PSI	A	2	S
Scott NXG7	45 Min 4500 PSI Low Pro	A	2	S
Scott NXG7	45 Min 4500 PSI	B	3	L
Scott NXG7	60 Min 4500 PSI	A	2	S
Sperian Panther	30 Min 4500 PSI	B	2	L
Sperian Panther	45 Min 4500 PSI Low Pro	A	2	S
Sperian Panther	45 Min 4500 PSI	B	2	L
Sperian Panther	60 Min 4500 PSI	A	2	S
Sperian Warrior	30 Min 4500 PSI	A	3	L
Sperian Warrior	45 Min 4500 PSI Low Pro	A	2	S
Sperian Warrior	45 Min 4500 PSI	B	3	L
Sperian Warrior	60 Min 4500 PSI	B	2	L

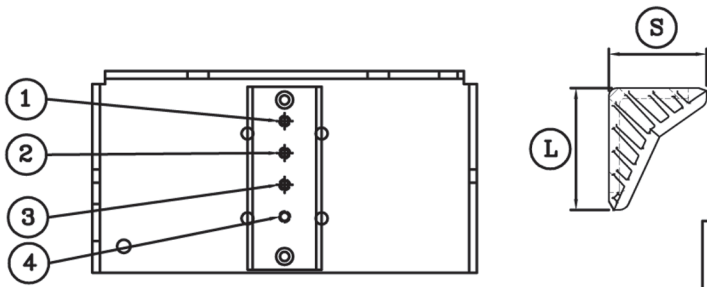

IN CASE SMALL DIAMETER BOTTLE DOES NOT REACH BUMPER.  
TURN SPACER BLOCK 180 DEG.

Bottle Length  
22.625 MIN  
25.250 MAX

Bottle Length  
18.750 MIN  
23.250 MAX

Bottle Length  
18.750 MIN  
23.250 MAX

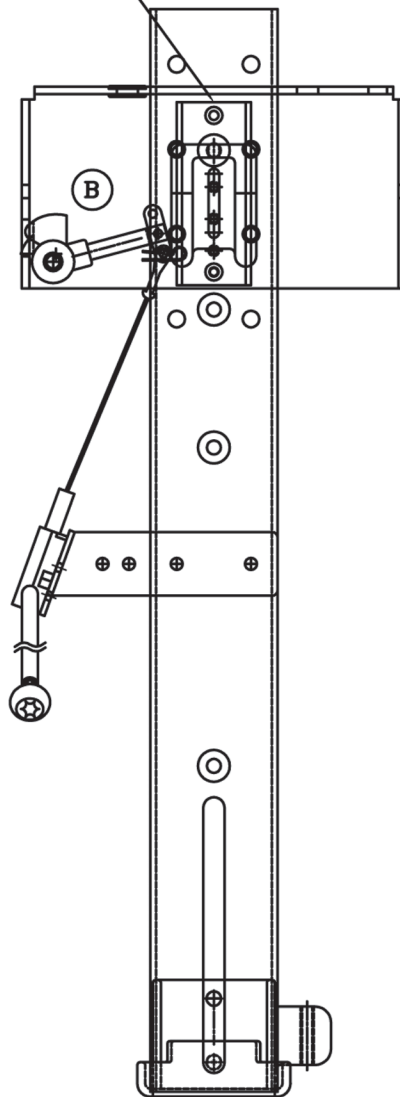
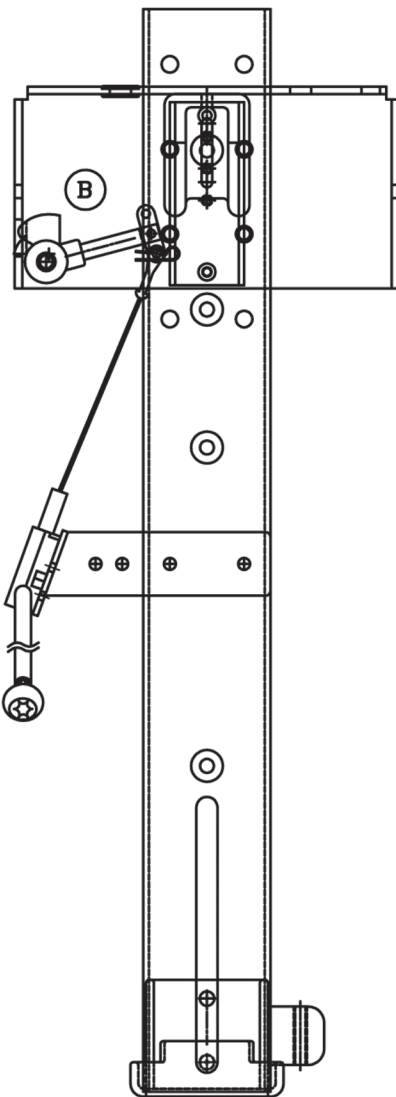
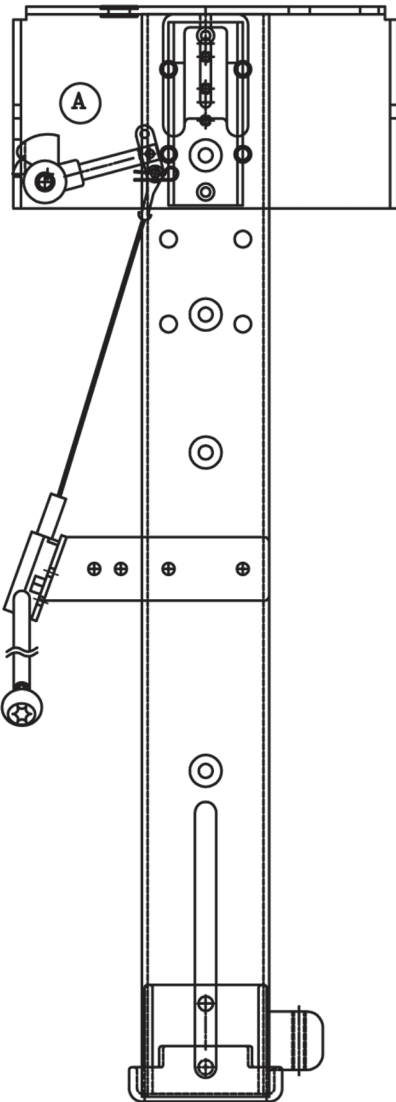

- 1) BOTTLE SHOULD BE FITTED TO BRACKET AS PER INSTRUCTION.
- 2) BACK PLATE MOUNT TO SEAT SO FOOT PLATE IS LEVEL OR CLOSE AS POSSIBLE TO TOP OF SEAT CUSHION.

**Figure 1**

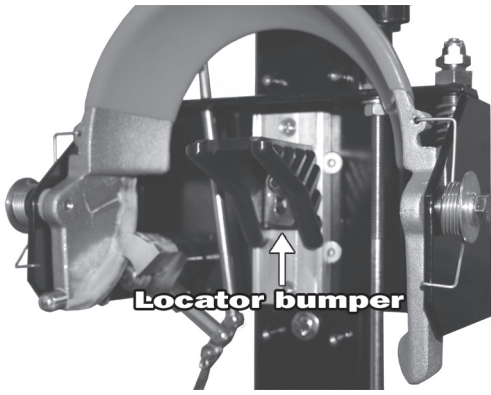

**Figure 2**

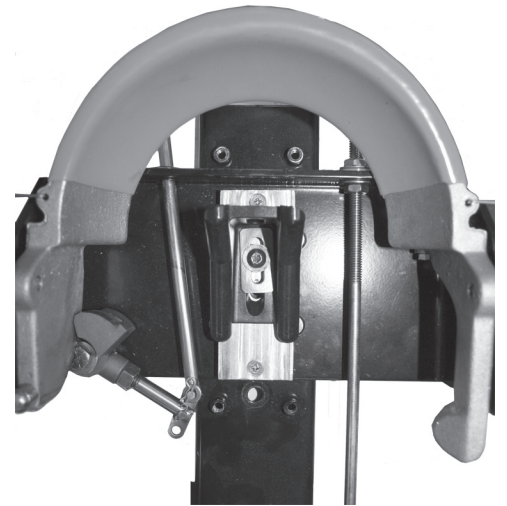

**Figure 2**

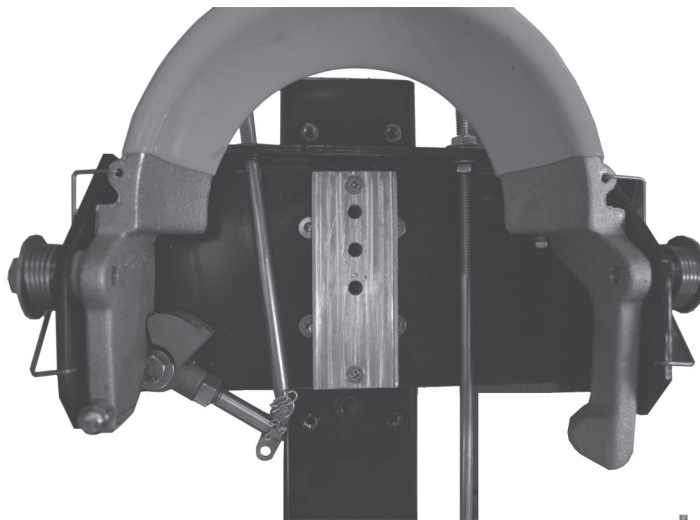

**If in position B**

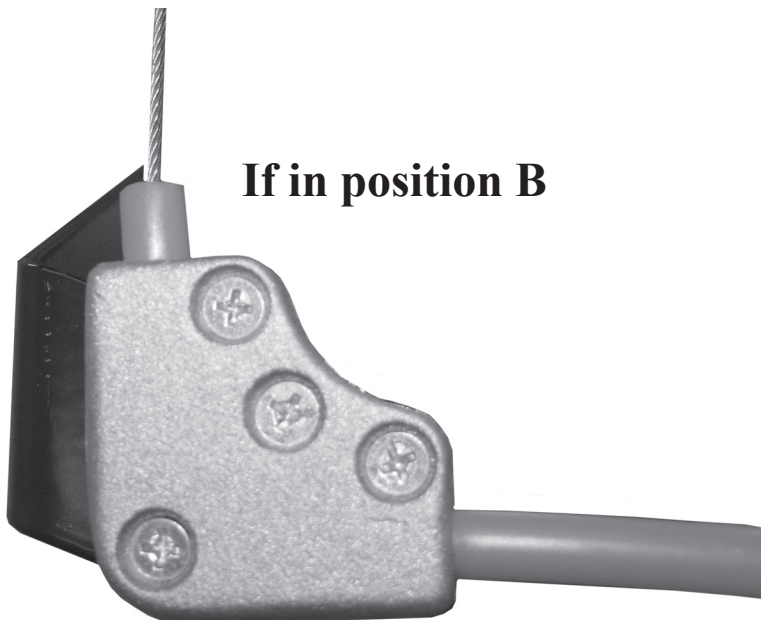

**If in position A**

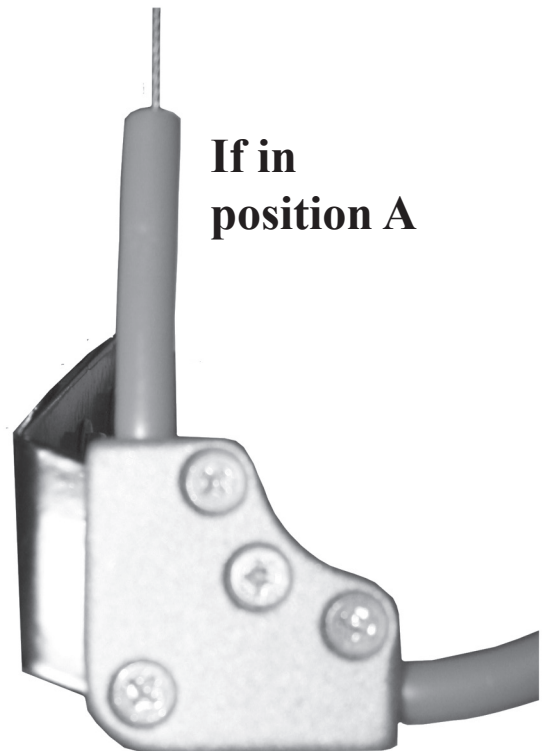

## Not proper set-up

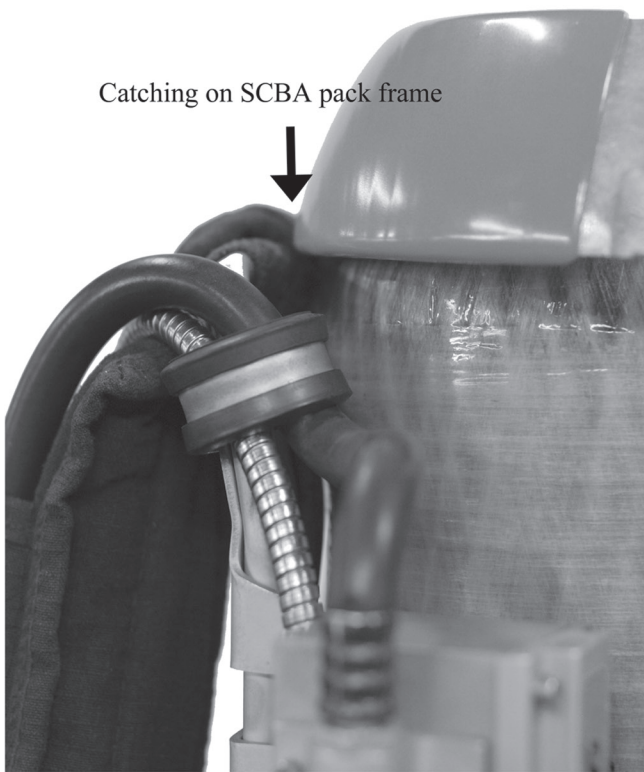

## Not proper set-up

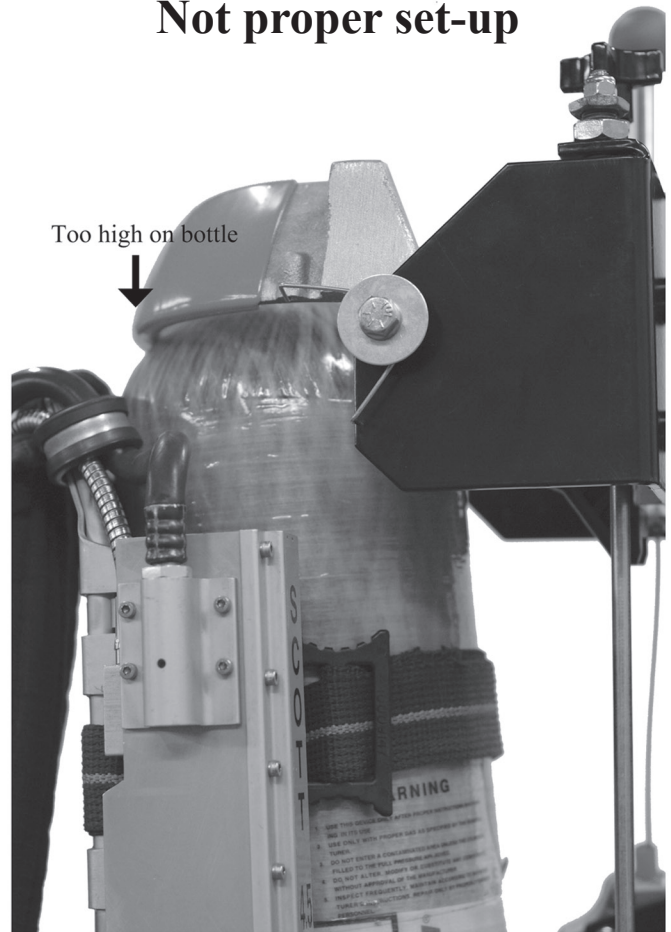

## Proper fit

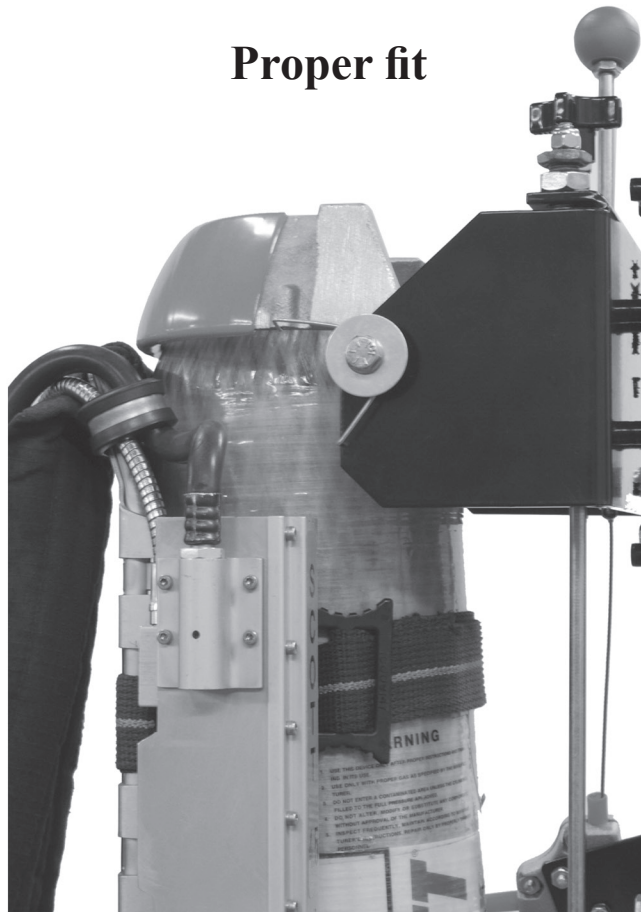

# Mounting Requirements - QUIC-LOCK

- Minimum of (2) mounting points at least 10" apart using 5/16" O.D. screws.
- Spacer required between Quic-Lock Backplate and mounting surface (*provided*).
- Mounting surface must be able to withstand a pull-out force of 450 lbs.

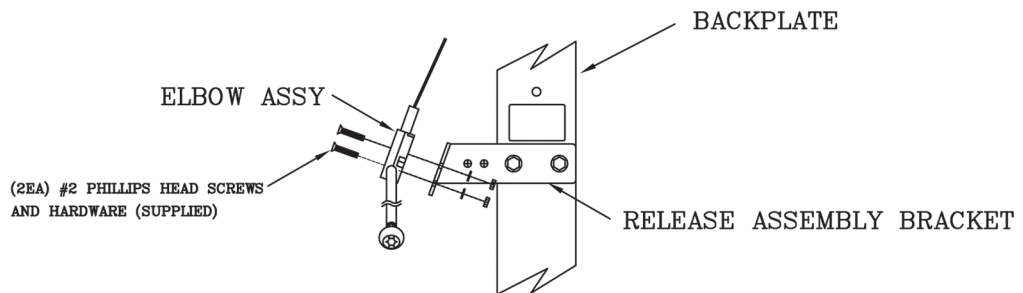
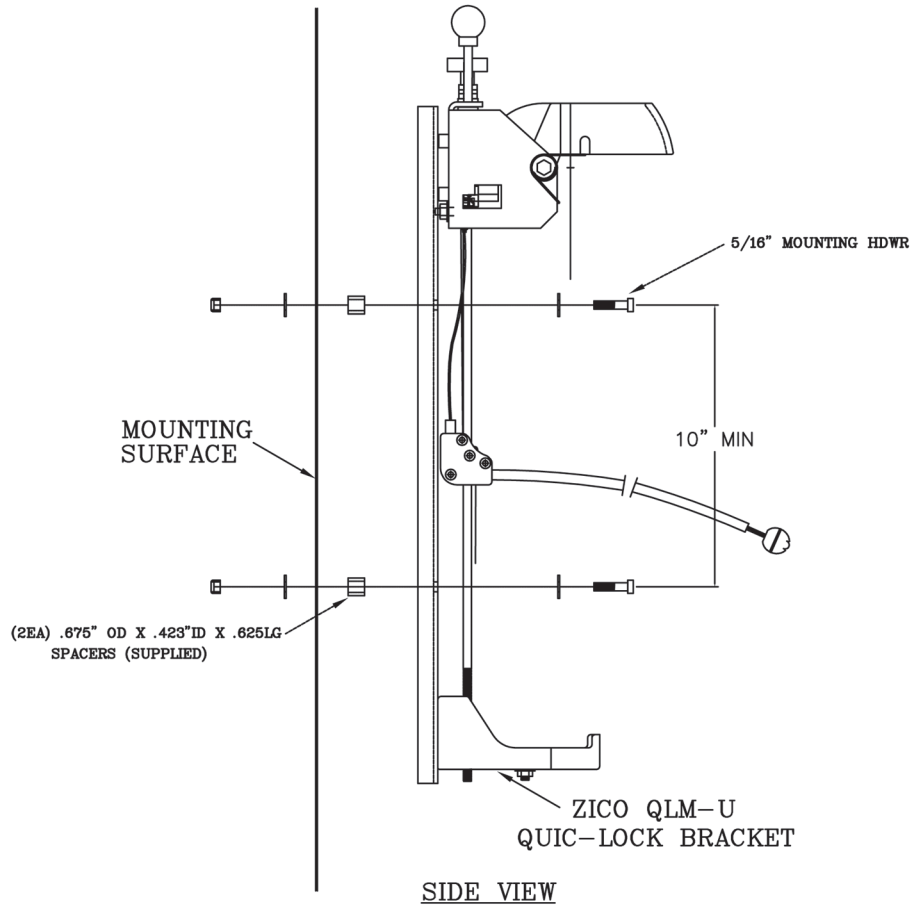

ATTACHING ELBOW ASSEMBLY TO  
RELEASE ASSEMBLY BRACKET

## Mounting Instruction - Optional Pull Release

---

1. Position the Pull Release Bracket, complete with yellow tube and release cable, in the desired location against the Seat Frame.
2. Mark position and using a #19 drill bit (.166), drill two (2) holes in the Seat Frame. Thicker Seat Frames may require a larger bit size, #18 (.169).
3. Attach the Pull Release Bracket to the Seat Frame using two (2) 10-32 x 3/8" thread forming screws (supplied). Be sure to carefully run the cable and conduit around the seat and bracket without causing kinks in the cable or interference with the bracket's functions.

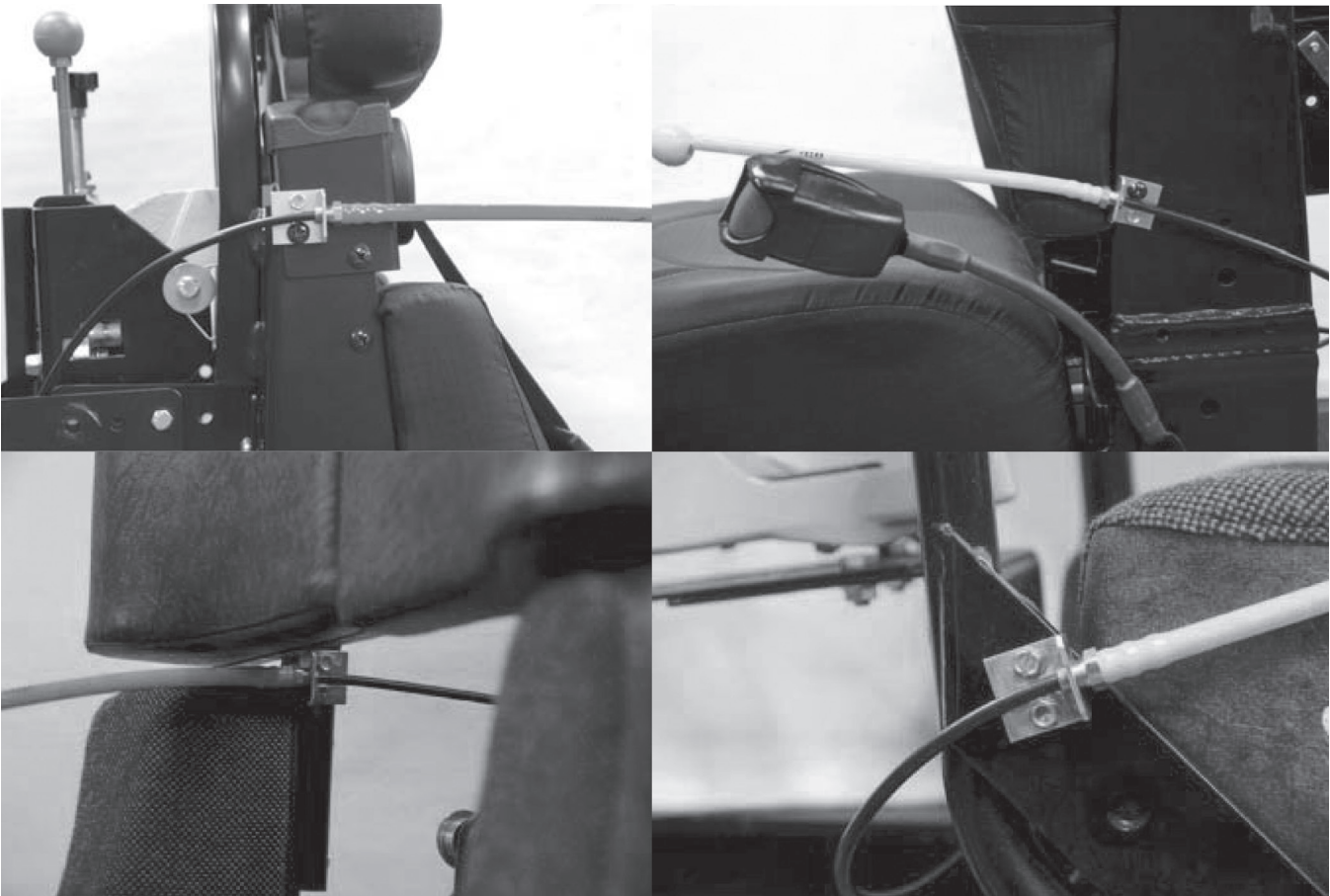

**Example of Possible Mounting Locations**

# Operating Instructions - QUIC-LOCK - Model QLM-U

*These instructions should only be used after the QLM-U has been adjusted for the SCBA that is being used.*

1. Place the valve of the SCBA in the Footplate. If the valve does not sit properly in the Footplate, the bracket will not lock safely.



2. Place the cylinder against the Cylinder Locator Bumper and pull the top clamp down.

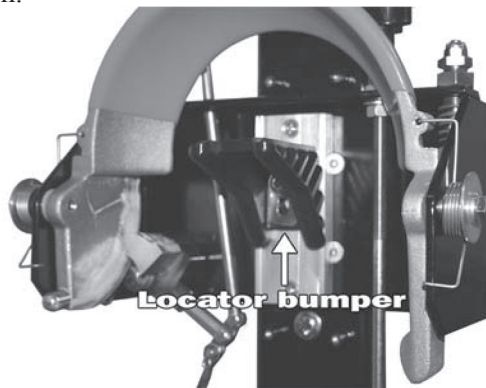

3. While applying downward pressure on the Top Clamp, pull up on the red Lock Lever Knob. When the knob is completely up, the SCBA is secured.



*Ziamatic Corp.*

10 West College Avenue, P.O. Box 337, Yardley, PA 19067-0587 • (215) 493-3618 • FAX: (215) 493-1401

\*ZICO is a registered trademark for fire, safety and marine products made by Ziamatic Corp.

[www.ziamatic.com](http://www.ziamatic.com)

TOLL FREE: 800-711-3473

Copyright Ziamatic Corp. 2-12