

**ROL-LOC® MECHANICAL BRACKET
MODEL QM-ROLO-SA-____
PARTS AND INSTRUCTION MANUAL**



Self-locking - simply press the cylinder through the rolling top clamp.

The Rol-Loc features a unique self-locking, PVC-coated top clamp to securely lock SCBA cylinders without the need for straps or levers.

To secure the cylinder, place the SCBA valve into the footplate, then press the cylinder against the top clamp. The top clamp will roll up and out of the way to accept the cylinder, and then lock closed behind it.

To release the SCBA, simply pull on the release cord.

NFPA compliant and third party tested to exceed the 9G standard.

Fits st SCBAs with only minor adjustments.

Easy to retrofit into new or old seats. Works with most center pull releases.

Note: Not to be used in place of a seat belt when used with SCBA harness.

Note: Due to slight variations in cylinder length between SCBAs of the same make and model, Zico strongly recommends the purchase of the Rol-Loc Adjustable Footplate Kit.

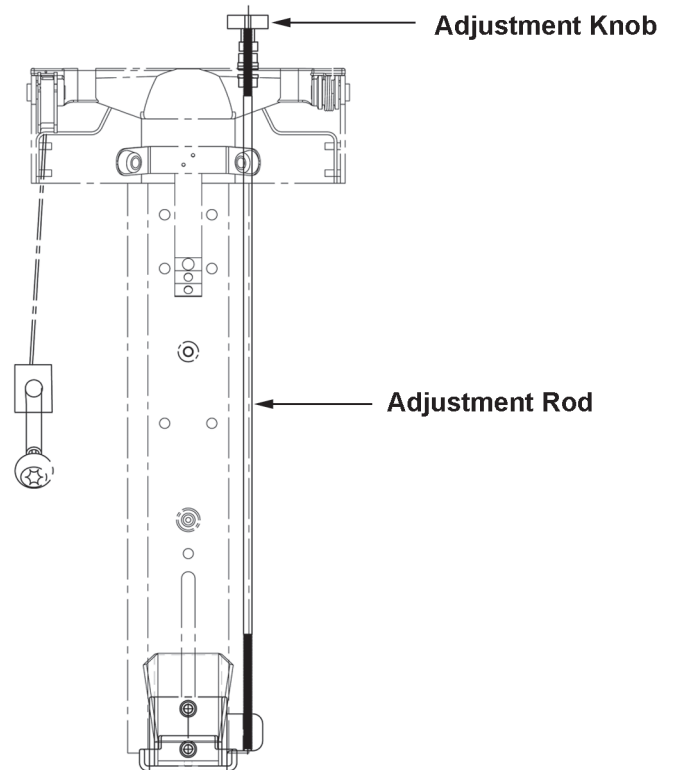

MODEL	DESCRIPTION	WT./@ IN LBS.
QM-ROLO-SA	Bracket, Stand Alone	18.3
QM-ROLO-SA-LSPR	Bracket, Stand Alone less Pull Release	17.9
QM-AF-R	Adjustable Footplate Kit	0.6

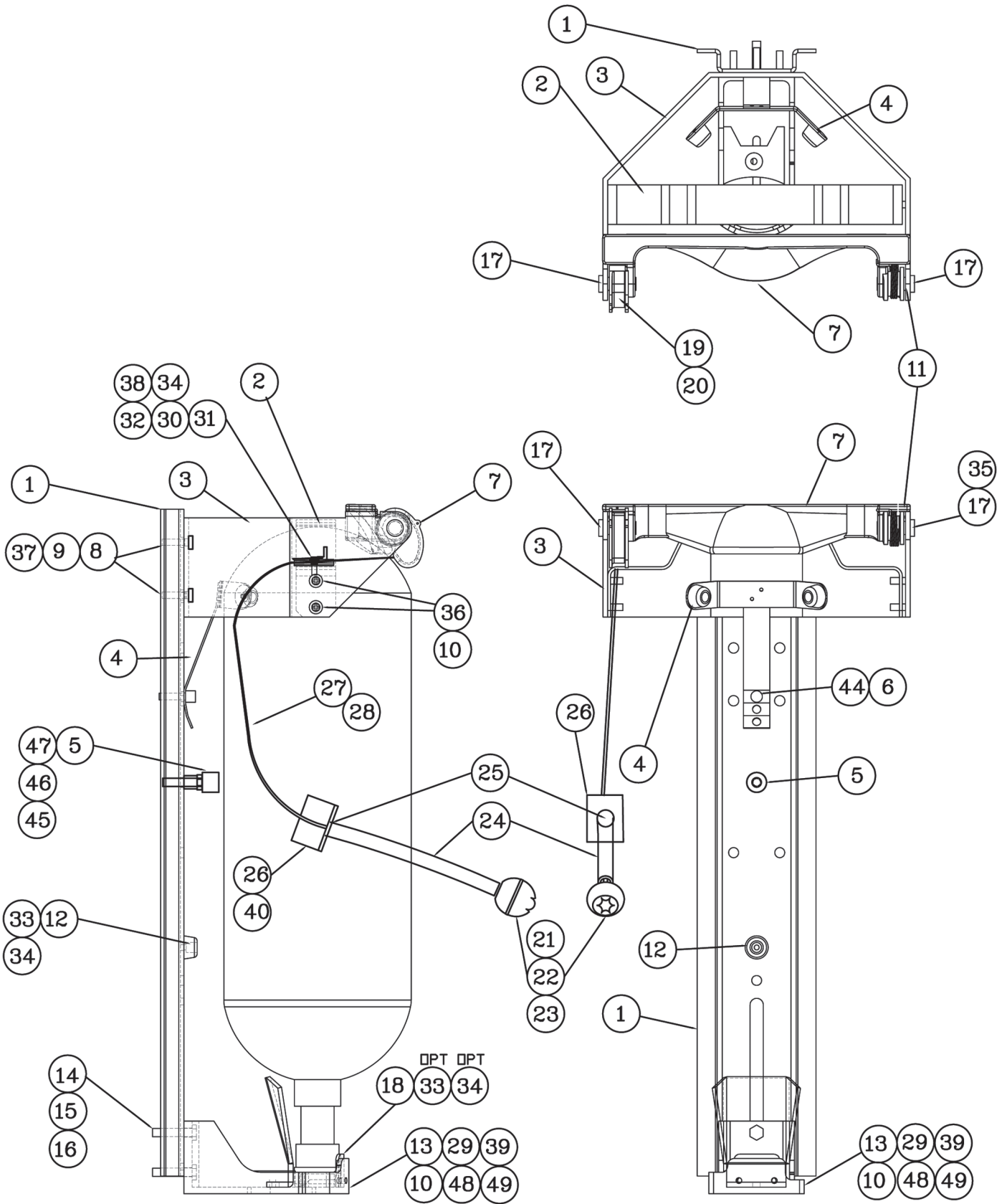

ITEM NO.	PART NO.	DESCRIPTION	QTY.
1	1027-110-101	Back Plate, Stand Alone Rol-Loc	1
2	1027-110-103	Upper Strap	1
3	1027-110-105	Upper Bracket	1
4	1027-105-910	Bumper Spring Assem.	1
5	1027-105-133	Cyl. Stop, 3/4 x 5/8, 5/16-18 Thrd.	1
6	9015-173100	5/16-18 NylockIns. Nut, ZPS, GR. 5	4
7	1027-105-101	Rotational Block Casting	1
8	9015-102512	1/4-20 x 3/4 Screw, Hex Hd.	4
9	9014-112500	1/4-20 Flat Washer, ZPS	4
10	9015-172500	1/4-20 Nylock Ins Nuts, ZPS, GR. 5	4
11	1027-105-111	Rotational Block Return Spring	1
12	1090-000-150	Rubber Bumper (ACSR)	1
13	1045-320-106	Foot Plate Guide	1
14	1029-105-127	Foot Plate Mounting Block	1
15	9014-203100	Lockwasher, 5/16 Dia., Split	4
16	9018-103116	Screw, 5/16-18 x 1" HH, Gr 8	2
17	9070-002020	Clevis Pin, ZPS, 1/2" x 1-1/2"	2
18	1027-110-109	MSA Extension (Optional)	1
19	9140-100612	Spring Pin, S/S, 1/16" x 3/4"	1
20	1027-105-139	Cable Guide	1
21	1045-320-169	Yellow Knob	1
22	1045-320-185	Knob Retainer	1
23	9010-391603	Retainer Set Screw	1
24	1027-105-131	Yellow Tubing, 10"	1
25	1010-175-131	Barb	1

ITEM NO.	PART NO.	DESCRIPTION	QTY.
26	1027-105-125	Pull Release Bracket	1
27	1027-105-127	Pull Release Cable	1
28	1027-105-129	Conduit w/Crimped Fitting	1
29	1045-320-115	Footplate Adjuster Block	1
30	9120-101305	#6 x 5/16 SS Drive Screw	1
31	1027-105-135	Pull Release Bracket Top	1
32	1027-105-137	Push Nut (for 6mm rod)	1
33	9010-352012	Screw, 10-32 x 3/4 BH ZPS Allen	3
34	9013-252000	Nut, 10-32 Hex Nylon Lock	4
35	9070-001212	Cotter Pin, 1/8 x 3/4 Steel	2
36	9010-162510	1/4-20 x 5/8" FH, PHIL 82 Deg., ZPS	4
37	9014-202500	Lockwasher, 1/4 Split	4
38	9010-222010	Screw, 10-32 x 5/8, PH, PHIL, ZPS	1
39	9014-132500	Washer, 1/4 Dia., Gr. 8, 1/16 Thk	1
40	9025-172006	Screw, 10-32 x 3/8, ZPS	2
41	9010-103124	Screw, 5/16-18 x 1-1/2 Hex Hd., ZPS	2
42	9014-113100	Flatwasher, 5/16ø NOM., ZPS	5
43	1045-320-139	Spacer, 3/8	2
44	9010-103112	Screw, 5/16-128 x 3/4, Hex Hd., ZPS	1
45	9010-573124	Stud, 5/16-18 x 1-1/2, ZPS	1
46	9010-573132	Stud, 5/16-18 x 2, ZPS	1
47	9112-203100	Nut, Jam 5/16-18 THIN, SS	1
48	9114-112500	Washer, 1/4 Dia. SS	1
49	9010-562520	Screw, 1/4-20 x 1/4" Torx Pan, ZPS	1

Preparing to Install

To provide optimum performance, the Rol-Loc must be mounted properly for the specific SCBA, air cylinder size, and seat model being used.

Your seat may need to be re-adjusted to fit your SCBA combination efficiently.

Here are some factors to be taken into consideration when mounting an SCBA bracket in a seat:

- The Rol-Loc bracket should be installed such that the Rol-Loc (when rotated open) does not bind with any part of the seat - including the head rest.

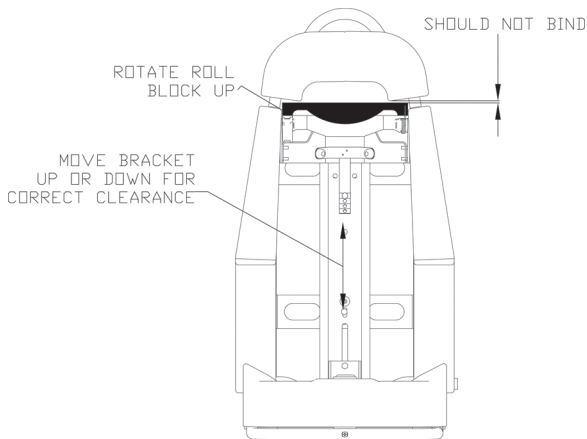

- Make sure the seat SCBA mounting brackets (or shroud) is adjusted back far enough to provide adequate clearance between the SCBA and the seat cushion.

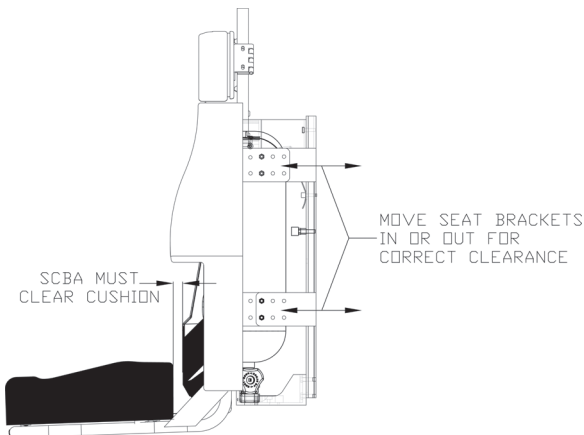

- Verify that the SCBA and Rol-Loc will fit around any structural members (tubing) near the bottom of the seat. The seat brackets (or shroud) may need to be adjusted in or out and up or down. Also, you may have to raise or lower the Rol-Loc bracket to achieve correct clearance.

Mounting the Rol-Loc to a seat

- Remove the 5/16-18 x 3/4" hex bolt from the spring assembly and detach the assembly from the bracket
- Find the position where the spring assembly mounting hole and bottom mounting hole line up to existing seat bracket mounting holes. (In some cases you may need to make a mounting hole.)
- Using the mounting hardware provided (5/16-18 x 1-1/2" hd bolt) position the bolt through the spring assembly in the specific position found in the chart provided below.

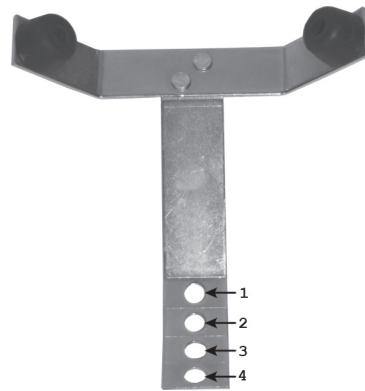

Hole Position	SCBA Cylinder Size
1	60 Min. Cyl.
2	45 Min., 30 Min. LP 2216 PSI, 30 Min. 3000 PSI
3	45 Min., 30 Min. LP 2216 PSI, 30 Min. 3000 PSI
4	30 Min. HP 4500 PSI

Note: Position 2 and 3 can be selected based on fitting preference.

- Take the spring assembly with the bolt in the correct position and mount it through the back plate in the same hole the spring assembly was unmounted from.

5. Apply the 3/8" spacer to the back of the bracket's backplate, onto the bolt holding the spring.
6. Mount the bracket with the spacer to the seat's mounting strap or shroud. Secure with a flat washer and 5/16-18 lock nut. (Do not tighten yet.)
7. Apply the lower mounting bolt with a flat washer through the lower mounting hole using the second spacer provided and secure with a lock nut.
8. Tighten top and bottom mounting bolts.

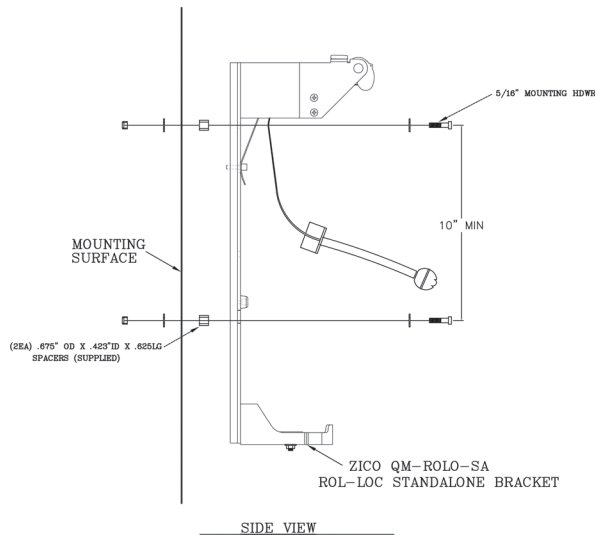

Rol-Loc Adjustment Procedure

1. Measure the overall length of your SCBA Air Cylinder from the bottom of the valve to the top of the cylinder.
2. Adjust the length between the footplate to the upper strap. The distance should be the length of your SCBA cylinder plus anywhere from 1/8" to a 1/2" for clearance of the upper strap.

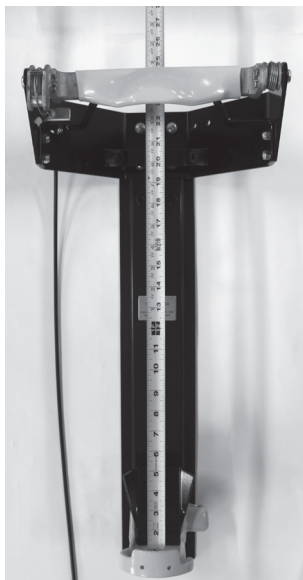

5. Remove the SCBA cylinder from the footplate and retighten the T-30 torx head screw holding the footplate guide.
6. Place your SCBA cylinder in the bracket and adjust the bumper bottle stop so that there is a 1/4" clearance from the bumper to the cylinder.

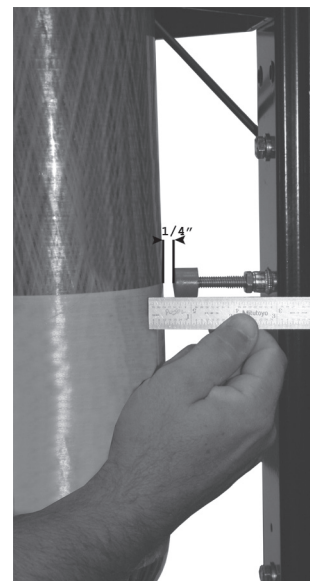

7. Attach the pull release bracket with the yellow tube and cable to the desired location on the seat frame by drilling (2) holes with a #19 drill (.166). Use (2) 10-32 x 3/8" thread forming screws to attach the bracket. (Thicker seat frame may require larger drill size, #18 .169.) Be sure to carefully run the cable and conduit around the seat and bracket without causing kinks in the cable housing or interference with the bracket's functioning.
8. Check the pull release for proper function.
9. If you place your cylinder in the bracket and feel it is loose, you may adjust the spring assembly to another position.

If using the Rol-Loc with an MSA SCBA cylinder, you must read this important safety information:

TO SAFELY SECURE YOUR MSA SCBA

If your MSA SCBA cylinder uses a gauge guard with the approximate dimensions shown in Ref. A, you must use the included adapter plate as shown in Ref. B, secured to the inside of the footplate as shown.

If your MSA SCBA cylinder has a **smaller** gauge guard, this adapter should not be used. Damage may result when using the adapter with a smaller gauge guard.

Ref. A

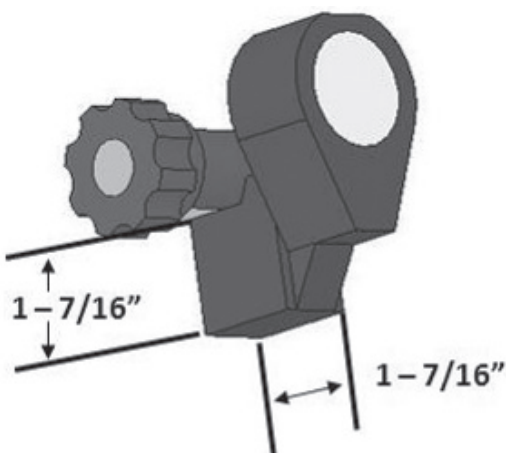

Ref. B

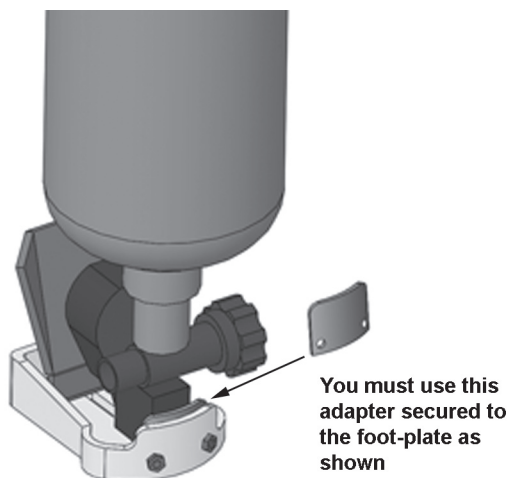

Ziamatic Corp.

10 West College Avenue, P.O. Box 337, Yardley, PA 19067-0587 • (215) 493-3618 • FAX: (215) 493-1401

*ZICO is a registered trademark for fire, safety and marine products made by Ziamatic Corp.

www.ziamatic.com

TOLL FREE: 800-711-3473

Copyright Ziamatic Corp. 11-13