

QUIC-LIFT™ LADDER ACCESS SYSTEM-HYDRAULIC MODEL LAS-HA2 PARTS AND INSTRUCTION MANUAL



I. SYSTEMS AVAILABLE

Refer to combination chart (page 14) for the correct combination number for the ladders you are using. Then contact Ziamatic Corp. to ascertain the LAS-HA2 system you require.

A. Ladder Access System - Hydraulic (LAS-HA2)

- | | | |
|----|--------------|--|
| 1. | LAS-HA2 | Basic unit |
| 2. | LAS-HA2-775 | Complete unit with 7-3/4" ladder support |
| 3. | LAS-HA2-975 | Complete unit with 9-3/4" ladder support |
| 4. | LAS-HA2-1200 | Complete unit with 12" ladder support |

II. STANDARD EQUIPMENT

The following items are included with each complete LAS-HA2 System:

A. Instruction Packet

Includes all information required to install a complete System. Wiring diagrams and parts lists are provided.

B. Control Switch - Model LAS-CHS (P/N 3097-500-156)

A single-pole, double-throw momentary toggle switch, a single-pole, single-throw on/off switch and a motor reversing relay are provided for operation of the system.

C. Flashing Light Kit - Model LAS-HA-FLK (P/N 3097-270-000)

NFPA 1901-96 requires flashing lights. These lights must flash unless the System is in the stored position. You may purchase an audio-visual alarm (see P/N 8047-125-000, Model AVA) and a relay, but they are not part of the standard System.

III. OPTIONAL EQUIPMENT

The following items may be added to any of the LAS-HA2 Systems.

A. LAS-FLB/PPMB

This square tube mount may also be used in conjunction with LAS-FLB. Allows mounting of pike pole mounting brackets in addition to folding ladder brackets.

B. LAS-FLB

This option allows you to carry a folding ladder and/or one length of hard sleeve in addition to your ladders. Brackets are to be mounted on top surface of pivot support casting (item 4, page 11 and pages 19 through 22). Tray Mounting Castings (HSS-TMC) must be ordered in addition to the LAS-FLB castings.

C. HSS-TMC

Tray mounting castings allow you to carry one length of hard sleeve in addition to your ladders. These castings mount on top of the LAS-FLB castings, which must also be ordered with this option (page 19) along with tray mount hardware (HSS-TMH) and a 10 foot tray (HSS-SAT-10).

Note: Failure to mount the hard sleeve tray using our tray mount casting (HSS-TMC) and tray mount hardware (HSS-TMH) will void your warranty. See Figure 6, page 19 for mounting information.

D. PPMB-__

Pike pole mounting brackets may be attached directly to LAS-HA2 via pre-drilled holes (Figure 13, page 22). Either single or double mounts may be used. Refer to the current ZICO catalog to order the pike pole mounting brackets required.

E. FLB/FLBA

Folding ladder brackets may be attached to LAS-FLB via pre-drilled holes. Refer to the current ZICO catalog to order the folding ladder brackets required.

F. 1-1/2" Spacer Set (P/N 3097-250-000)

In some instances the Ladder Access System must be raised up to accommodate extra-wide ladders. When this occurs, a set of four 1-1/2" high spacers will be required for proper mounting of the ladders.

G. LAS-LGK

Ladder Guard Kit contains one tube of epoxy and two stainless steel guards. The guards may be attached to the ladder rungs to prevent wear and possible damage as a result of the locking handle's contact with the rung (see Figure 23, page 32).

H. LLAS-MLS

The Manual Locking System (Figure 17, page 26) provides a positive means of retaining the ladders. The lock must be de-activated prior to operating the electrical control. This is done by pulling outward on the strap (item 99, page 27) or pushing back on the handle (item 77, page 27).

I. LLAS-ELS

The Electric Locking System (Figure 19, page 28) is activated by pressing down on the operating switch allowing the small electric actuators to open the locking mechanisms. After a momentary delay, the main electric actuators lower the System. The electric locking system may also be operated manually (see page 28).

IV. GENERAL INSTALLATION INFORMATION

The Ladder Access System-Hydraulic was designed for ladders meeting the current NFPA 1931 standard. Systems accommodate most ladder combinations. For ladders over 35 feet or with tormentor poles, contact Ziamatic Corp. for assistance. Combinations (see page 14) 36, 44, 53, 63, 72, 80, 126, 128, 129, 130, 132, 133, 144, 152, 154, 157, 158, and 159 require ladder mounts in excess of 12 inches. Some of these combinations may be accommodated by adding spacers behind the ladder mount and retainer handle support, but this will increase the mounting depth and the ladders may protrude excessively beyond the side of the vehicle. We do not recommend this.

Note: The weight of ladders and/or hard sleeves may not exceed 300 pounds with any of the Systems.

A. Mounting Points

The Ladder Access devices should be placed symmetrically in reference to the ladder. The same number of rungs should extend past each ladder support (page 18). This will ensure that both units are lifting approximately the same weight (if this is not possible, contact Ziamatic Corp.). Bolt holes have been provided on both the vertical and horizontal mounting surfaces. Although the device may be securely mounted from the horizontal surface only, it is a great advantage to be able to use mounting bolts on the vertical surface as well. One-half inch thick aluminum backing plates should be used if using only vertical or horizontal hole sets for mounting (see Section V.A., last paragraph).

All bolts should have reinforcement structure added underneath the mounting surface where possible. Channel or rectangular tube should be used instead of flat plate as reinforcement. If aluminum plate is used, it should be 1/2" thick (see page 16).

B. Electrical Circuit

The control switch should be a momentary single-pole double-throw exterior 25 amp switch. We provide a control switch, on/off switch, and fwd/rev relay with each system. It should be placed in such a position that the operator has full view of the QUIC-LIFT System and personnel that might come in contact with it. Using wires of equal length between power source and actuators will help to keep the actuators running in synchronization (see page 17 for wiring diagrams).

The control switch should be mounted in a waterproof compartment.

Several "Lock Out" circuits may be considered to prevent accidents from occurring. An ideal "Lock Out" system would only permit operation when the ignition switch is on, the transmission is in park, and any obstructing compartment doors are shut. Because of the higher amperage required to operate the QUIC-LIFT System, a separate "Lock Out" circuit should be used (see electrical diagrams on page 17). The "Lock Out" circuit should be separated from the QUIC-LIFT System circuit by a relay. This will prevent damage to the existing wiring system. The QUIC-LIFT System circuit should be protected by an 80 amp fuse.

NFPA 1901-96 standard requires flashing lights be provided, facing the front and rear of the apparatus. Lights must flash whenever the System is out of the stored position. All systems include a Flashing Light Kit. An audio visual alarm may still be ordered as an option (see model AVA, P/N 8047-125-000 in catalog).

C. Synchronization of Actuators

If you experience any problems associated with the LAS-HA2, we will require the serial number off of your device. The serial number can be found on a metal tag on the side of the base casting.

It is important to the operation of the QUIC-LIFT System that the actuators work in synchronization. The actuators may be out of sync a considerable amount before binding occurs, however, reducing the occurrence of this will increase the life of the actuators and prevent damage or wear to the ladders. Keeping the load evenly distributed on the two devices will help to keep the actuators running in synchronization (Figure 5, page 18).

Do not permit personnel to hang, sit or stand on ladders or hose while stored on the QUIC-LIFT System. If the unit is overloaded, an internal relief valve will open to prevent damage to the actuators and mechanical components.

We have extensively tested our QUIC-LIFT System and have found the normal life to be in excess of 5,000 cycles without failure. With reasonable care and maintenance, your QUIC-LIFT System should give you many years of excellent service.

V. INSTALLING THE LADDER ACCESS SYSTEM

A. Preparation for Mounting

Check both units to verify they have matching serial numbers.

Plan and lay out the entire installation before making any cuts or drilling holes in the body of the fire apparatus. This will keep "out of service" time to a minimum and also help to minimize mistakes. Review Electrical System on page 17 before any holes are drilled into the apparatus.

Lay the two units on the shelf of the apparatus so that you can see where holes will be required for the mounting bolts. There should be a sufficiently-sized flat surface underneath the mounting holes, free of seams and obstructions where the bolts will pass through. Raise the ladders near the two units to determine where they will lay when installed. The ladders must be evenly supported by each unit (the same number of rungs should extend on the outer side of each ladder support).

When the ladder is raised and lowered in this position, it should clear protruding objects on the apparatus such as emergency lights, hand rails, etc. Make sure that when the ladders are in the up position they do not obstruct cross lays or hose reels.

A. Preparation for Mounting (continued)

Measure the "resting" depth of your ladder combination to determine how far your ladders will protrude out from the hose bed wall (add depth of 6-1/4" for the retracted LAS-HA2 System). In the event that the actuator retainer casting or inner arm casting (item 2, page 11) come into contact with the stiffening rib at the top of the hose bed, you may have to notch out the stiffening rib to recess the device (see page 16). In the event that the stiffening rib is notched, the exposed metal surfaces should be painted and covered with an edge guard material. In addition, and in particular, if the stiffening rib is notched, you may wish to add a backing plate (page 16) on the inside surface of the hose bed wall. The plate will reinforce the hose bed wall and provide a good mounting support for the QUIC-LIFT System. The edges should be rounded off, on the side next to the hose, and flat head bolts should be used to mount the plate.

Bolts 3/8" or larger should be used to mount the base castings to the fire apparatus. When the bases are to be mounted to the hose bed wall or only mounted to the shelf deck, 1/2" bolts should be used with substantial backing plates (page 16) and supports. If you are installing the QUIC-LIFT devices to only one surface, we suggest you contact one of our technicians before beginning.

B. Electrical System

Now that you are sure of your mounting position, you may begin to lay out your electrical wiring (pages 17 and 31). At this time, it is a good idea to remove the units from the shelf and "C" clamp them to a table so that the units will swing out away from the table when lowered. Units should be mounted the same distance back from edge of table as they would be on the shelf of your apparatus. Be sure the table is secured by adding a counterweight to the other side before lowering the units. Place ladders onto the ladder mount castings just as they will be stored on the apparatus. Determine where wires can be run so they will not be visible from the outside of the apparatus. We recommend all electrical connections be soldered as this method is superior to crimp connections. Measure the required run lengths of each wire (see page 17 for proper wire diameter).

Make up a wiring harness using wires longer than the required run lengths. Temporarily make all wire connections so you can test the system. With the table properly secured, you should be able to operate the units with the ladders or hard sleeves attached. Be sure the ladders will clear the edge of the table before drilling any holes in the apparatus. If they do not, spacers may be required.

The flashing light kit (model LAS-HA-FLK) must be also installed. The wiring diagram for the flashing lights may be found on page 23.

C. Mounting Suggestions

The Control Switch should be mounted in a clean, waterproof compartment.

A "WARNING" label (part number 3097-105-149, item 49, page 12) is supplied with each QUIC-LIFT System. The pressure sensitive label must be mounted by the electrical control switch. All apparatus operators must be instructed to keep area in front of ladders clear of personnel when the QUIC-LIFT System is being raised or lowered.

Before starting the installation, you should make sure you have all necessary tools and materials. This should include matching touch-up paint, edge trim (for cut outs), fender protector cloths and removable tape (to protect paint), necessary hardware, wire connectors, cable ties, burr remover, vacuum cleaner (for metal filings), edge guards (for wiring), drills, drill gun, wrenches, step ladders, etc. Be sure to allow yourself sufficient time to do a proper installation, keeping in mind that you will probably have to remove the hose from the hose bed.

Following these simple instructions should make your installation easy and professional.

VI. TROUBLESHOOTING

All units are tested after final assembly to ensure proper operation and adjustment. No further adjustments should be required unless excess vibration is noted (see VI. D., page 8).

A. Actuator "Creeping Down"

An indicator light may be installed in the cab of your vehicle to warn the driver when the System is out of the stored position. If this light comes on while the vehicle is in motion, it may be an indicator that one of the actuators is "creeping down". The actuator will not drop suddenly but the driver should keep an eye on the System until reaching the destination. Then the switch may be activated to retract the System to the stored position.

B. Ladder Wider Than Ladder Support

If the proper ladder combination is specified at the time of ordering, this problem should not occur. The standard support channel is 25-1/4" long. Spacer set (part number 3097-250-000) may be ordered to raise system.

C. One Actuator Running Two Or More Seconds Slower Than The Other

When one actuator is running more than two seconds behind the other, it is normally due to some type of resistance in the wiring system. Check all wire connections to make sure they are secure. Make sure to fully extend and retract both actuators at the end of each up and down cycle. If they are still greatly out of sync, after checking the wiring and running units to the end of each cycle, you may switch the actuators to confirm if the problem is in the wiring system. After removing the ladders, remove the nut/bolt assembly to remove the actuator. Switch the two actuators and reassemble. If the rear unit actuator was originally running slower and this unit is still running slower then the problem is in the wiring. If the problem switches from rear unit actuator running slower to front unit running slower after the switch, then the problem may be the actuator.

D. Emergency Operation

If the System fails to lower from the stored position, do not attempt to repair until the unit is returned to the station.

If the System fails to raise from the down position, the following emergency procedure may be used:

1. Remove the ladders from the system.
2. With one person holding the ladder mount casting (7), a second person should remove the top shoulder bolt, nut, and washer that retains the actuator.
3. Lift unit to its stored position and secure in place.
4. Replace shoulder bolt, nut, and washer.
5. Follow same procedure for the second unit.
6. Ladders can be repositioned onto the system for return trip to station.

VII. DRAWINGS, DIAGRAMS AND CHARTS

A. Ladder Access System - Hydraulic (LAS-HA2)

1. Combination numbers for LAS-HA2 Systems (Chart 2, page 14)
2. Standard model shown with optional spacer blocks under base casting (Figure 1, page 13)
3. Parts list - Model LAS-HA2-____ (Chart 1, page 11 and 12)
4. Side view - Model LAS-HA2-____ (Figure 2, page 15)
5. Common installation using stiffening/backing plate (Figure 3, page 16)
6. Electrical diagram for QUIC-LIFT Systems (Figure 4, page 17)
7. Front view of LAS-HA2 System (Figure 5, page 18)
8. Handle assembly (Figure 17, page 25)

B. QUIC-LIFT System - Optional Equipment

1. Model LAS-FLB castings attached to pivot support casting (Figure 10, page 21)
2. HSS-TMC tray mount castings (Figure 6, page 19)
3. Model LAS-FLB/PPMB added to support PPMB-AA or PPMB-BB (Figure 12, page 22)
4. Model PPMB-AA or PPMB-BB pike pole mounting brackets attached directly to inside arm castings (Figure 13, page 22)
5. Part Number 3097-250-000 spacer set under base casting (Figure 1, page 13)
6. Model LAS-HA-FLK flashing light kit (pages 23 & 24)
7. Model LLAS-MLS manual locking system (pages 26 & 27)
8. Model LLAS-ELS electric locking system (pages 27 through 31)
9. Model LAS-LGK ladder guard kit (Figure 22, page 32)

VIII. MAINTENANCE

A. Semi-Annually Or At Scheduled Apparatus Lube Service

1. Lubrication - We suggest that all pivoting surfaces be sprayed, in the joints and pivot points, with CRC brand Stor&Lube long-term lubricant and rust preventative #03032. Excess lubrication should be wiped off.
2. Actuator - We suggest the exposed shaft be cleaned and sprayed with WD-40 or a similar light, moisture-repelling silicon type lubricant.

B. Pressure Washing

Do not operate pressure washer around or near the actuators. Excessive pressure may allow soap and water to blow past the seal, damaging the actuator.

IX. SERVICE

If you experience any problems with your Ladder Access System, please call us at 800-711-3473 for assistance. **Please have the serial number of your System available.** This number can be found stamped into a metal plate on the back of the base castings.

X. WARRANTY

A copy of the warranty registration **MUST** be returned to ZICO to ensure registration of your System (page 34).

CHART 1. PARTS LIST

MODEL LAS-HA2-_____

| ITEM NO. | PART NUMBER | NAME | MAT'L. | DESCRIPTION | MODEL NUMBERS | | | |
|----------|--------------|--------------------------|--------|-------------------------------------|---------------|--|---------|----------|
| | | | | | LAS BASIC | LAS 775 | LAS 975 | LAS 1200 |
| 1 | 3097-900-101 | Base Casting (Universal) | ALUM | --- | 1 | 1 | 1 | 1 |
| 2 | 3097-105-102 | Inside Arm Casting | ALUM | --- | 1 | 1 | 1 | 1 |
| 3 | 3097-105-103 | Outside Arm Casting | ALUM | --- | 2 | 2 | 2 | 2 |
| 4 | 3097-105-104 | Pivot Support Casting | ALUM | --- | 1 | 1 | 1 | 1 |
| 5 | 9110-103124 | Hex Hd Bolt | SST | 5/16-18 x 1-1/2 | 2 | 2 | 2 | 2 |
| 6 | 9112-103100 | Hex Hd Nut | SST | 5/16-18 | 2 | 2 | 2 | 2 |
| 7 | 3097-105-111 | Ladder Mount Casting | ALUM | Size 7-3/4 | - | 1 | - | - |
| | 3097-165-107 | Ladder Mount Casting | ALUM | Size 9-3/4 | - | - | 1 | - |
| | 3097-105-135 | Ladder Mount Casting | ALUM | Size 12 | - | - | - | 1 |
| 8 | 3097-105-125 | Retainer Housing, Short | STL | --- | - | 1 DETERMINED FROM LADDER COMBINATION | | |
| | 3097-165-125 | Retainer Housing, Medium | STL | --- | - | | | |
| | 3097-145-125 | Retainer Housing, Long | STL | --- | - | | | |
| 9 | 3097-105-115 | Actuator Retainer Pin | SZP | Size 1/2 Dia x 5 3/8 | 1 | 1 | 1 | 1 |
| 10 | 9010-315032 | Shoulder Bolt (3/8-16) | SZP | Size 1/2 x 2 | 2 | 2 | 2 | 2 |
| 11 | 9010-315024 | Shoulder Bolt (3/8-16) | SZP | Size 1/2 x 1-1/2 | 2 | 2 | 2 | 2 |
| 12 | 9010-315028 | Shoulder Bolt (3/8-16) | SZP | Size 1/2 x 1-3/4 | 2 | 2 | 2 | 2 |
| 13 | --- | Liquid Threadlocker * | | As Required | A/R | A/R | A/R | A/R |
| 14 | 9010-315012 | Shoulder Bolt (3/8-16) | SZP | Size 1/2 x 3/4 | 2 | 2 | 2 | 2 |
| 15 | 9010-315040 | Shoulder Bolt (3/8-16) | SZP | Size 1/2 x 2-1/2 | 2 | 2 | 2 | 2 |
| 16 | 9113-173700 | Hex Hd Locknut | SST | Size 3/8-16 | 8 | 8 | 8 | 8 |
| 17 | 9114-203700 | Lock Washer | SST | Size 3/8 I.D. | 6 | 8 | 8 | 8 |
| 18 | 3097-105-118 | Setscrew, 7/8-14 | STL | --- | - | 1 | 1 | 1 |
| 19 | 3097-105-119 | Wear Strip | PLSTC | 7 5/8" Long | - | 1 | - | - |
| | 3097-165-119 | Wear Strip | PLSTC | 9 3/4" Long | - | - | 1 | - |
| | 3097-145-119 | Wear Strip | PLSTC | 12 1/16" Long | - | - | - | 1 |
| 20 | 3097-105-120 | Reflective Tape | P.S. | --- | - | 1 | 1 | 1 |
| 21 | 3097-105-121 | Retaining Ring | SZP | --- | - | 1 | 1 | 1 |
| 22 | 9110-333718 | Socket Hd C/S | SST | Size 3/8-16 x 1-1/8 | 6 | 6 | 6 | 6 |
| 23 | 3097-805-114 | Hydraulic Actuator | --- | Parker PN 647087 | 1 | 1 | 1 | 1 |
| 24 | 3097-105-109 | Handle Casting | ALUM | --- | - | 1 | 1 | 1 |
| 26 | 3095-180-105 | Support, Retainer Handle | ALUM | --- | - | 1 | 1 | 1 |
| 27 | 9010-3350104 | Soc Hd Cap Screw | SZP | Size 1/2-13 x 6 1/2 | - | 1 | 1 | 1 |
| 28 | 3097-105-113 | Compression Spring | --- | --- | - | 1 | 1 | 1 |
| 29 | 9140-101220 | Spring Pin | SST | Size 1/8 Dia x 1-1/4 | 1 | 1 | 1 | 1 |
| 30 | 3097-105-130 | Nylon Washer | PLAS | 1/2 ID x 3/4 OD x .062 | - | 1 | 1 | 1 |
| 31 | 9113-173100 | Nylon Lock Nut | S.S. | 5/16-18 | - | 2 | 2 | 2 |
| 32 | 3097-105-116 | Ladder Pad | PLAS | Size 1/8 Tk x 2 x 4 | - | 4 | 4 | 4 |
| 33 | 9110-242016 | Screw, 10-32 x 1" | --- | RNS S/S Phil | 2 | 2 | 2 | 2 |
| 34 | 3097-105-161 | Adhesive - Double Sided | --- | 2 x 4 (Use w/Item 32) | A/R | A/R | A/R | A/R |
| 35 | 9010-333132 | Screw, 5/16-18 x 2 | SZP | Socket Head | - | 2 | 2 | 2 |
| 36 | 9018-103128 | Screw, 5/16-18 x 1-3/4 | S.S. | Hex Cap | - | 2 | 2 | 2 |
| 37 | 9013-133100 | Hexnut, 5/16-18 Selflock | SZP | --- | - | 2 | 2 | 2 |
| 38 | 3097-500-157 | Toggle Switch | --- | On/Off | 1 | 1 | 1 | 1 |
| 39 | 3098-400-115 | Relay, Fwd/Reverse | --- | --- | 1 | 1 | 1 | 1 |
| 40 | 3098-400-117 | Relay Cover | --- | --- | 1 | 1 | 1 | 1 |
| 41 | 9114-251900 | Lockwasher | --- | #10 Int Tooth | 2 | 2 | 2 | 2 |
| 42 | 9114-113700 | Flat Washer | SST | Size 3/8 I.D. | 6 | 6 | 6 | 6 |
| 43 | 9114-103700 | Spacer, Shoulder Screw | SST | Size 3/8 ID x 1/2 OD x .062 Thk. | 14 | 14 | 14 | 14 |

* = NOT SHOWN

A/R = AS REQUIRED

OPT = OPTIONAL

CHART 1. PARTS LIST (continued)
MODEL LAS-HA2-_____

| ITEM NO. | PART NUMBER | NAME | MAT'L. | DESCRIPTION | MODEL NUMBERS | | | |
|----------|---------------|-----------------------------|--------|----------------------|---------------|---------|---------|----------|
| | | | | | LAS BASIC | LAS 775 | LAS 975 | LAS 1200 |
| 44 | 3097-500-156 | Toggle Switch * | --- | Up/Down | 1 | 1 | 1 | 1 |
| 45 | 3097-105-145 | Boot, Toggle Switch | --- | --- | 2 | 2 | 2 | 2 |
| 46 | 9110-453720 | Hex Hd Bolt/1/16 Hole | SST | 3/8-16 x 1-1/4 | 1 | 1 | 1 | 1 |
| 47 | 9018-453732 | Hex Hd Bolt/1/16 Hole | SZP | 3/8-16 x 2 | 1 | 1 | 1 | 1 |
| 48 | 3097-105-148 | Actuator Retainer Cast | ALUM | --- | 1 | 1 | 1 | 1 |
| 49 | 3097-105-149 | Label # Scotchlite | P.S. | Keep Clear Of Area | 1 | 1 | 1 | 1 |
| 50 | 9014-353700 | Spher Washer (Set = 2 Pcs.) | STL | Size 3/8, Blk-Oxide | 1 | 1 | 1 | 1 |
| 51 | 3098-400-109 | Actuator Spacer | STL | --- | 3 | 3 | 3 | 3 |
| 53 | 3097-105-153 | Safety Wire - 8" Lg. | SST | .032ø 302/304 Wire | 1 | 1 | 1 | 1 |
| 54 | 3097-105-154 | Channel Support | ALUM | 25 1/4" Long | 1 | 1 | 1 | 1 |
| | 3097-105-155 | Channel Support | ALUM | 27" Long | OPT | OPT | OPT | OPT |
| 56 | 3097-870-000 | Flashing Light Kit * | --- | --- | 1 | 1 | 1 | 1 |
| 57 | 30-97-105-157 | Base Spacer | ALUM | (2 Req'd.) | OPT | OPT | OPT | OPT |
| 58 | 3097-105-158 | Label * | P.S. | Vibration Warning | 1 | 1 | 1 | 1 |
| 59 | --- | --- | --- | --- | --- | --- | --- | --- |
| 60 | 3097-105-160 | Wear Strip, Ret. Handle | --- | --- | --- | 1 | 1 | 1 |
| 61 | 9110-103720 | Hex Cap Screw | S.SI. | 3/8-16 x 1 1/4 | 2 | 2 | 2 | 2 |
| 62 | 3097-105-162 | Label * | P.S. | "TO PREVENT WEAR..." | 1 | 1 | 1 | 1 |
| 63 | 3097-105-163 | Tag, "Factory Set" | PAPER | --- | --- | 1 | 1 | 1 |
| 69 | --- | --- | --- | --- | --- | --- | --- | --- |
| 70 | 3097-870-101 | NFPA Switch Spacer | --- | --- | 1 | 1 | 1 | 1 |
| 71 | 3098-105-164 | NFPA Switch Bracket | --- | --- | 1 | 1 | 1 | 1 |

* = NOT SHOWN

A/R = AS REQUIRED

OPT = OPTIONAL

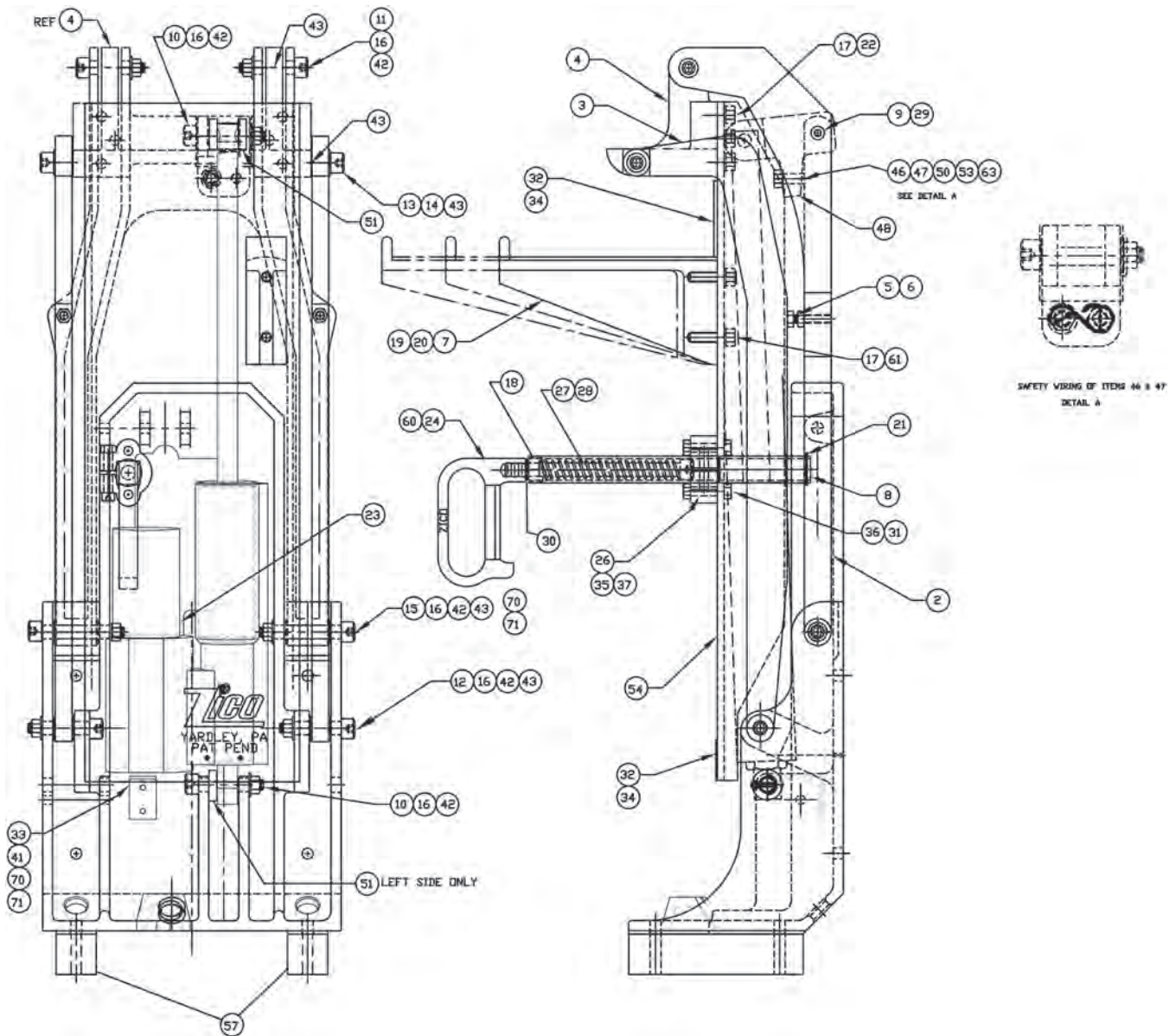

FIGURE 1. MODEL LAS-HA2-___
STANDARD MODEL SHOWN WITH OPTIONAL
SPACER BLOCKS UNDER BASE CASTING
SEE CHART 2 FOR COMBINATION NO.'S
REQUIRING SPACER BLOCKS

CHART 2. COMBINATION NUMBERS FOR LAS SYSTEMS

| <u>EXTENSION LADDER</u> | <u>ROOF LADDER</u> | <u>Alco Lite</u> | <u>Duo Safety</u> | | | | | | | |
|-----------------------------|--------------------|--|--|--|-----------------------------------|--------------------|--------------------|---------------------|-----------------------------------|-----------------------------------|
| | | PRL 8' - 20' ALP-100 8'-20' | FRL 8' - 20' ALP-F-415 8'-20' | TRL 12' - 28' ALP-015 12'-28' | Y.G.R. 10'-20' | 775 10'-14' | 875 16'-20' | 1275 25'-30' | 575C 10'-25' | 575C 30' |
| Alco Lite 2 Section | | | | | | | | | | |
| TEL 20' - 35' | ALP-020 20'-35' | 1 | 2 | 3 | 4 ⁽¹⁾ | 5 | 6 | 7 | 8 ⁽¹⁾ | 9 ⁽¹⁾ |
| TEL 12' - 24' | ALP-200-12'-24' | 10 | 11 | 12 | 13 | 14 | 15 | 16 | 17 | 18 |
| TEL 28' - 35' | ALP-200 28'-35' | 19 | 20 | 21 | 22 | 23 | 24 | 25 | 26 | 27 |
| FEL 12' - 35' | ALP-F-420 12'-35' | 28 | 29 | 30 | 31 | 32 | 33 | 34 | 35 ⁽¹⁾ | 36 ⁽¹⁾ |
| Alco Lite 3 Section | | | | | | | | | | |
| TEL3 24' - 35' | ALP-030 24'-35' | 37 ⁽¹⁾ | 38 ⁽¹⁾ | 39 ⁽¹⁾ | 40 ⁽¹⁾ | 41 ⁽¹⁾ | 42 ⁽¹⁾ | 43 ⁽¹⁾ | 44 ⁽¹⁾ | 45 |
| | ALP-030N 24'-35' | 46 ⁽¹⁾ | 47 ⁽¹⁾ | 48 ⁽¹⁾ | 49 ⁽¹⁾ | 50 ⁽¹⁾ | 51 ⁽¹⁾ | 52 ⁽¹⁾ | 53 ⁽¹⁾ | 54 |
| | PEL3 24' | 55 | 56 | 57 | 58 | 59 | 60 | 61 | 62 | 63 ⁽³⁾ |
| | PEL3 28' - 35' | 64 | 65 | 66 | 67 | 68 | 69 | 70 | 71 | 72 ⁽³⁾ |
| | ALP-300 28"-35' | 73 | 74 | 75 | 76 | 77 | 78 | 79 | 80 ⁽³⁾ | 81 |
| Duo Safety 2 Section | | | | | | | | | | |
| | Y.G.E.-2 16'-35' | 82 ⁽¹⁾ | 83 ⁽¹⁾ | 84 ⁽¹⁾ | 85 ⁽¹⁾ | 86 ⁽¹⁾ | 87 ⁽¹⁾ | 88 ⁽¹⁾ | 89 ⁽¹⁾ | 90 ⁽¹⁾ |
| | 900 20'-24' | 91 | 92 | 93 | 94 | 95 | 96 | 97 | 98 ⁽¹⁾ | 99 ⁽¹⁾ |
| | 1200 28'-35' | 100 ⁽¹⁾ | 101 ⁽¹⁾ | 102 ⁽¹⁾ | 103 ⁽¹⁾ | 104 ⁽¹⁾ | 105 ⁽¹⁾ | 106 ⁽¹⁾ | 107 ⁽¹⁾ | 108 ⁽¹⁾ |
| | 500-C 14'-24' | 109 ⁽¹⁾ | 110 ⁽¹⁾ | 111 ⁽¹⁾ | 112 ⁽¹⁾ | 113 ⁽¹⁾ | 114 ⁽¹⁾ | 115 ⁽¹⁾ | 116 ⁽¹⁾ ₍₂₎ | 117 ⁽¹⁾ ₍₂₎ |
| | 500-C 28'-35' | 118 ⁽¹⁾ | 119 ⁽¹⁾ ₍₂₎ | 120 ⁽¹⁾ | 121 ⁽¹⁾ ₍₂₎ | 122 ⁽¹⁾ | 123 ⁽¹⁾ | 124 ⁽¹⁾ | 125 ⁽¹⁾ | 126 ⁽¹⁾ ₍₂₎ |
| Duo Safety 3 Section | | | | | | | | | | |
| | Y.G.E.-3 28'-35' | 127 ⁽¹⁾ | 128 ⁽¹⁾ | 129 ⁽¹⁾ | 130 ⁽¹⁾ | 131 ⁽¹⁾ | 132 ⁽¹⁾ | 133 ⁽¹⁾ | 134 | 135 |
| | 925 22'-26' | 136 | 137 | 138 | 139 | 140 | 141 | 142 | 143 | 144 ⁽³⁾ |
| | 1225 28'-35' | 145 | 146 | 147 | 148 | 149 | 150 | 151 | 152 ⁽³⁾ | 153 |
| | 525C 28'-35' | 154 ⁽³⁾ | 155 | 156 | 157 ⁽³⁾ | 158 ⁽³⁾ | 159 ⁽³⁾ | 160 | 161 | 162 |

**NO LADDERS WITH POLES AND NO LADDERS OVER 35' (UNLESS SPECIAL ORDER WITH APPROVAL)
WEIGHT OF LADDERS AND/OR HARD SLEEVE MAY NOT EXCEED 300 POUNDS**

⁽¹⁾ USE 27" LONG CHANNEL AND 3097-250-000 SPACER SET UNDER BASE CASTING

⁽²⁾ EXTENSION LADDER WEIGHT RESTS ON ROOF LADDER

⁽³⁾ USE 1" SPACER (3097-105-136) BETWEEN LADDER MOUNT CASTING AND CHANNEL

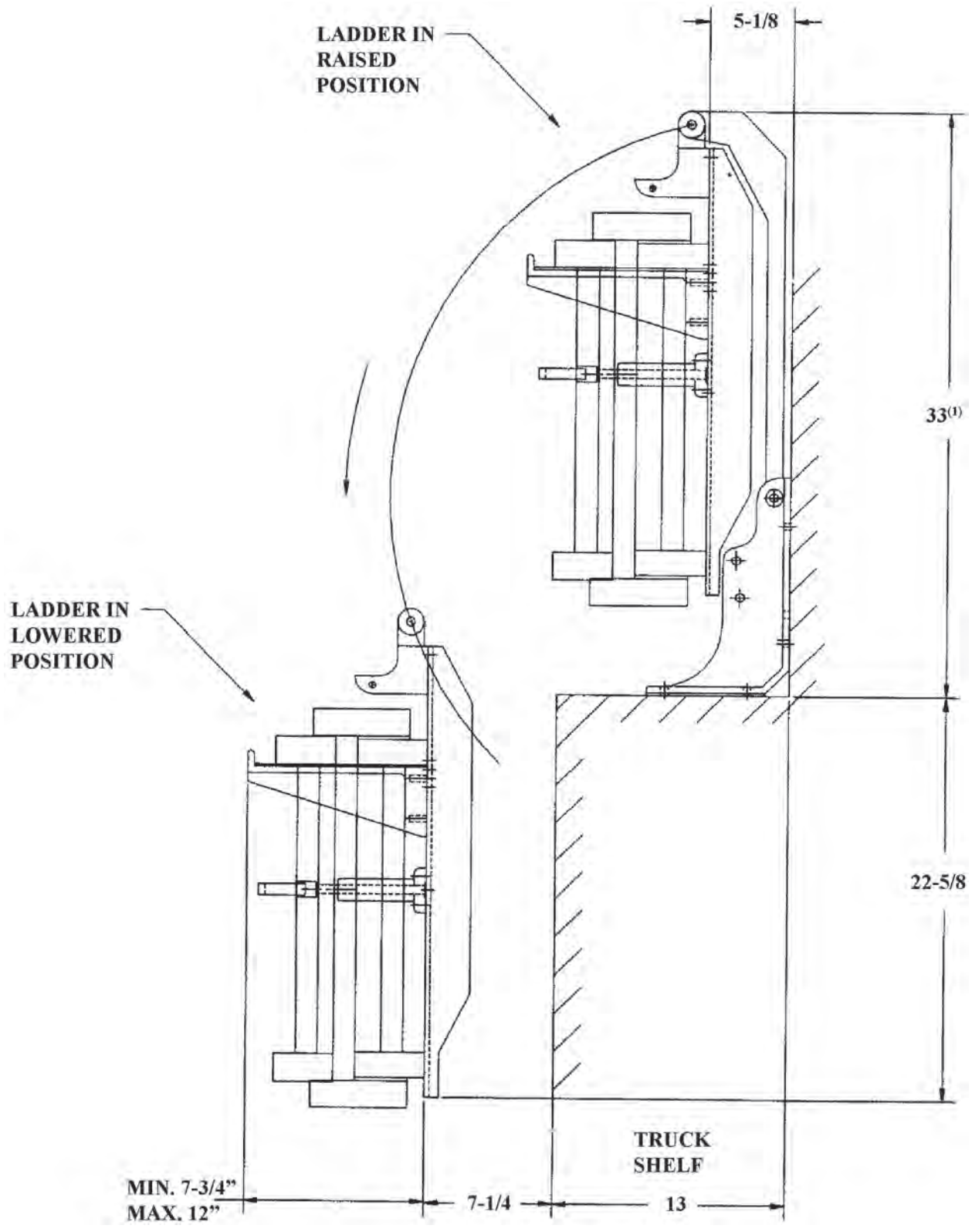

FIGURE 2. SIDE VIEW MODEL LAS-HA2-_____

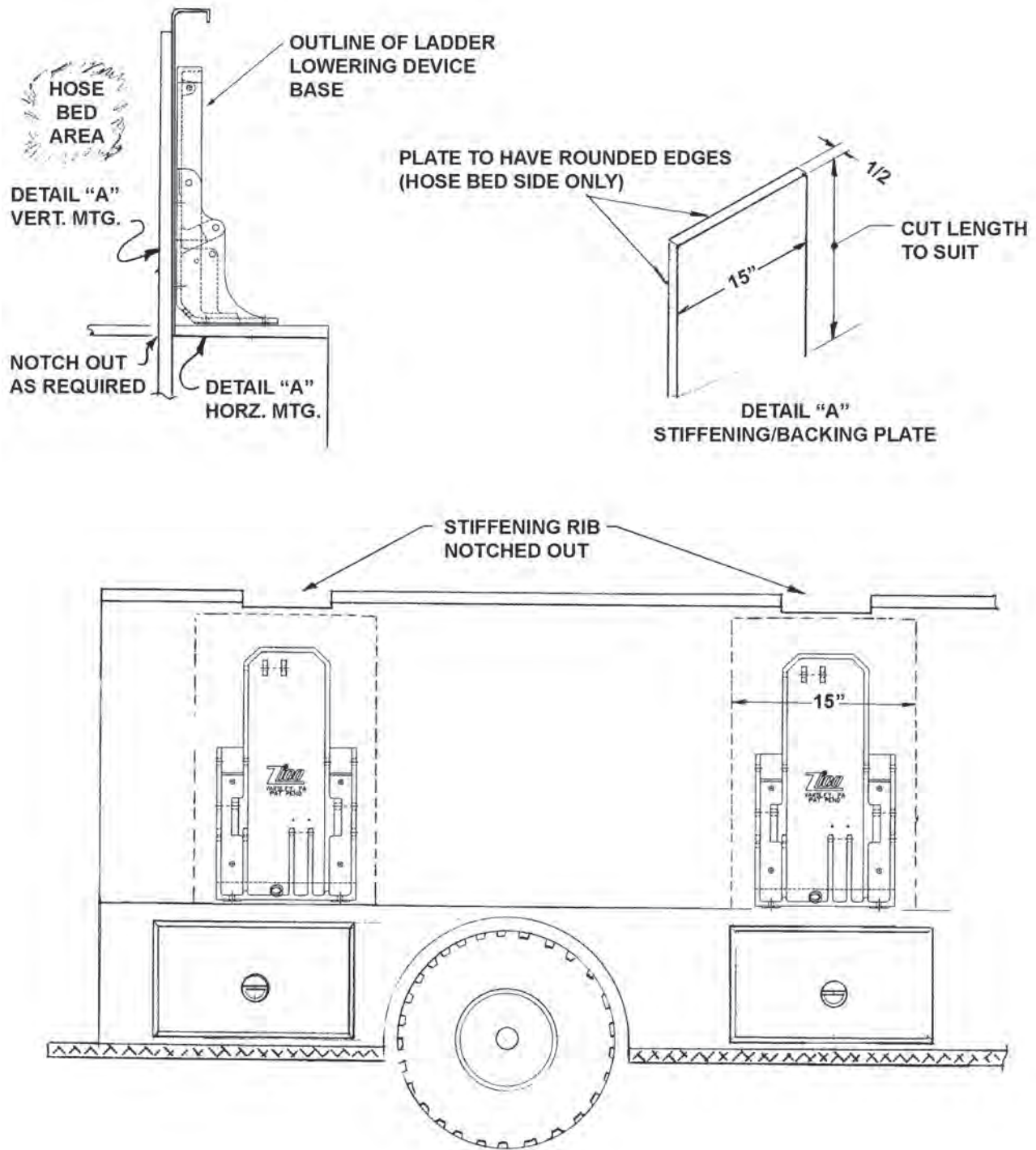
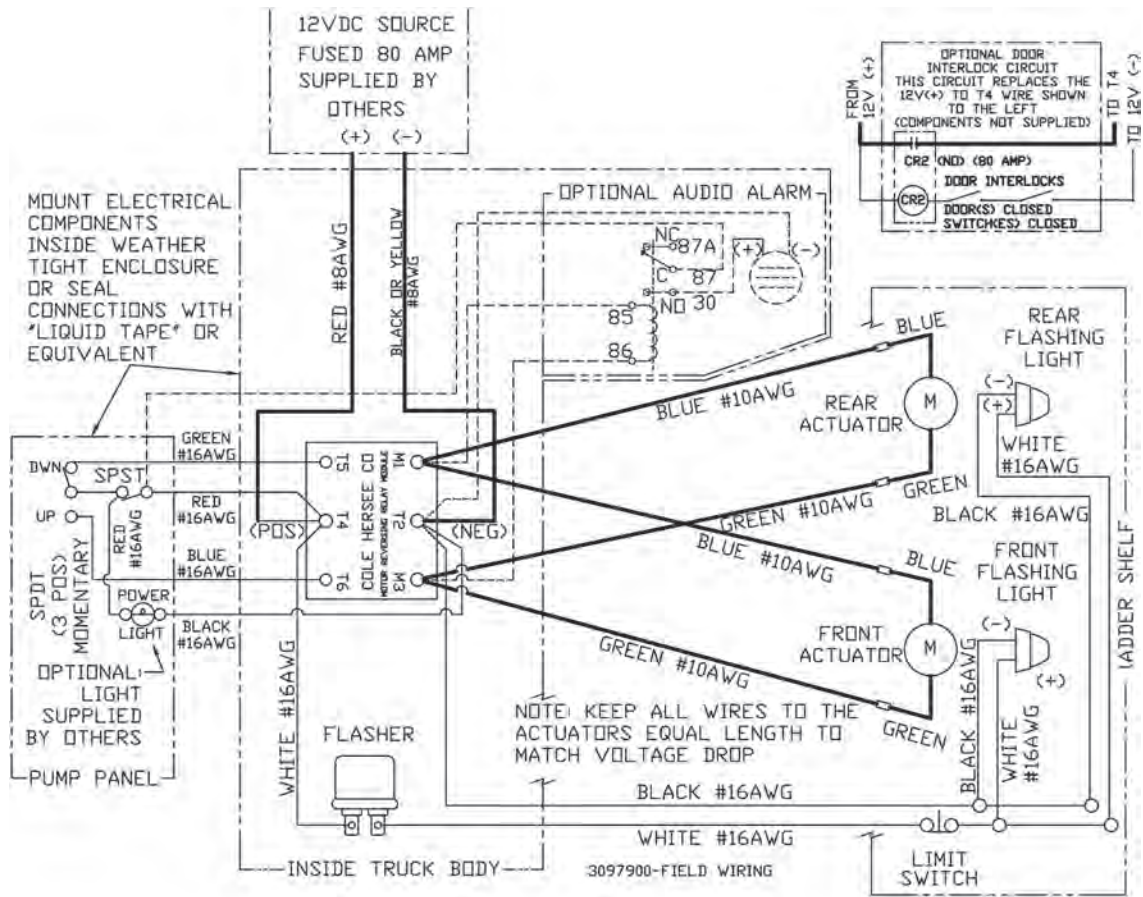

FIGURE 3. COMMON INSTALLATION USING STIFFENING/BACKING PLATE



LAS-XT-XXX
ZICO/COLE-HERSEE
MOTOR REVERSING RELAY MODULE
LOGIC

| UP-DOWN SWITCH MODE | RLY MODL INPUT COMMAND | RLY MODL OUTPUT POLARITY | ACTUATOR POLARITY |
|---------------------|------------------------|--------------------------|-----------------------|
| UP | T4 (+12V) T5 | M1 POS M3 NEG | BLUE POS GREEN NEG |
| DOWN | T4 (+12V) T6 | M1 NEG M3 POS | BLUE NEG GREEN POS |

SHOWN W/ TYPICAL WIRE
COLOR AND GAUGE

FIGURE 4.
ELECTRICAL SYSTEM
SHOWN WITH OPTIONAL AUDIO/VISUAL ALARM WITH RELAY

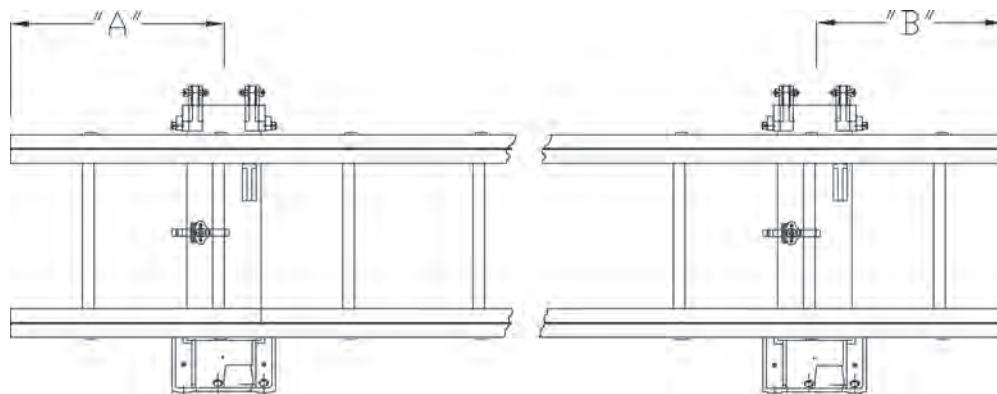
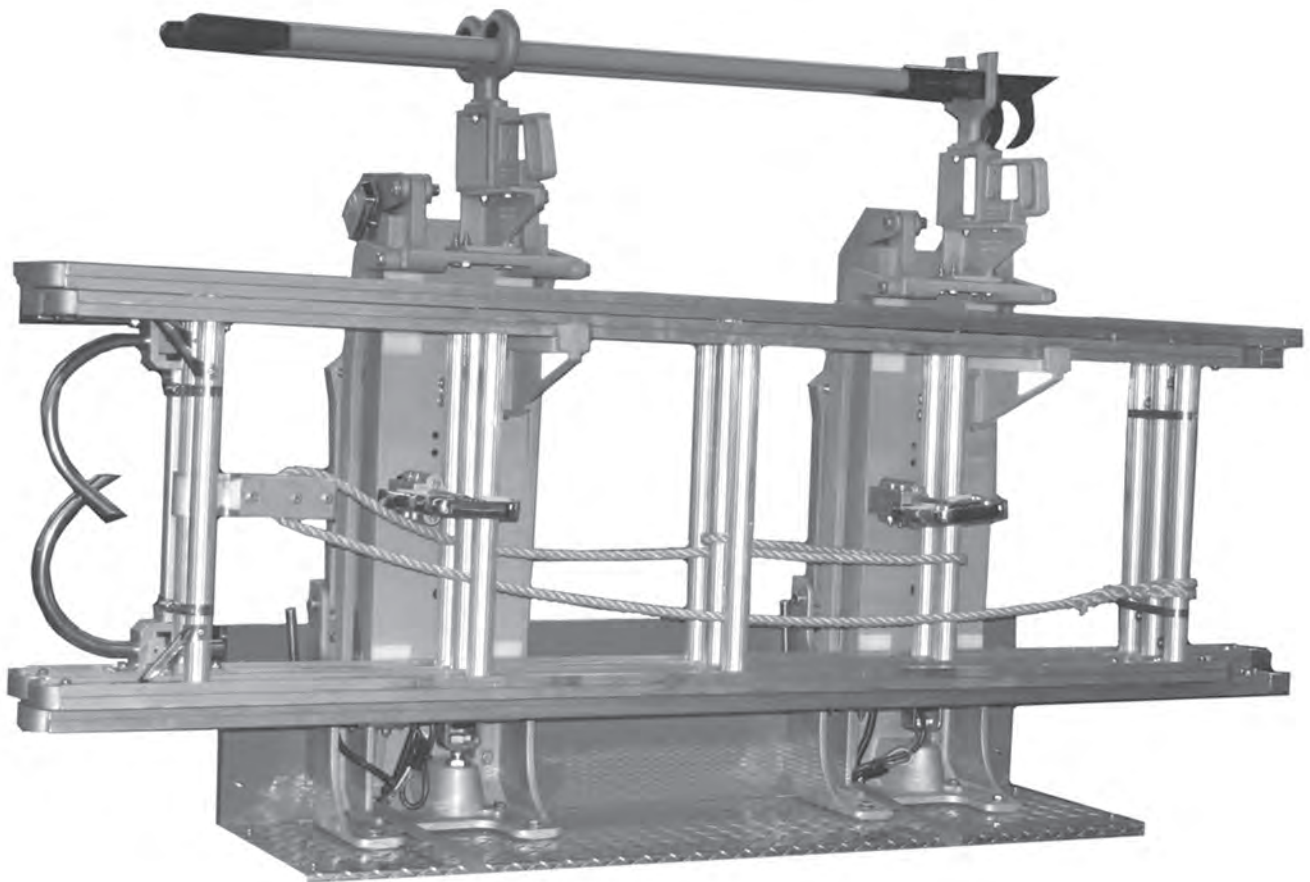
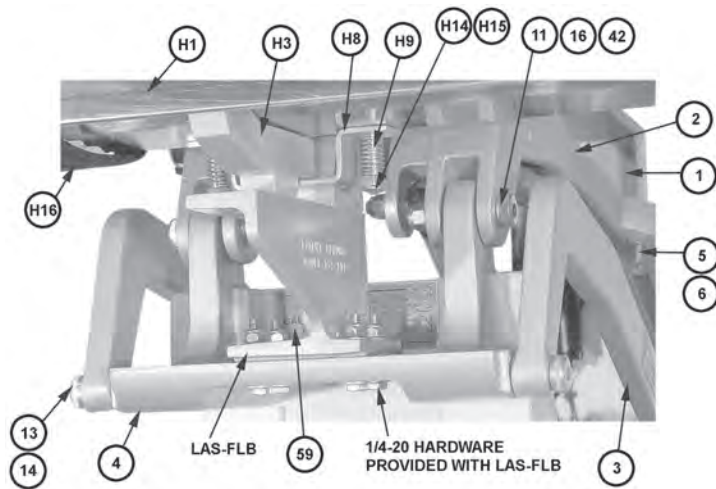

FIGURE 5.
FRONT VIEW OF LAS SYSTEM

NOTE EQUAL NUMBER OF RUNGS TO LEFT (A) AND RIGHT (B) OF DEVICE

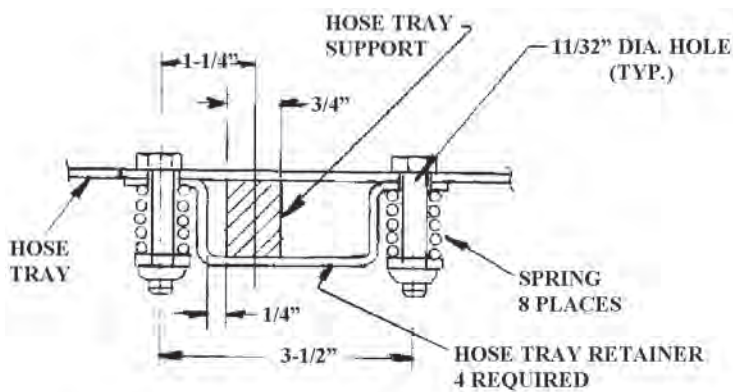
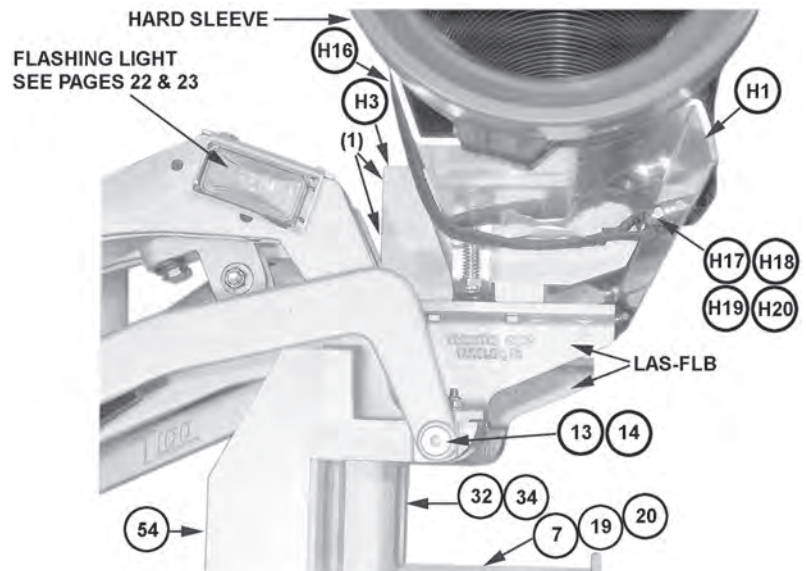

**FIGURE 6.
HARD SLEEVE TRAY
MOUNTED ON
LAS-HA2-___ SYSTEM.
REQUIRES LAS-FLB SET**

(1) H12 AND H13 WOULD BOLT THROUGH CHANNEL (54) AND INTO HOSE RAY SUPPORT CASTING (H3) ON THE HSS-___ SYSTEM.

HSS-TMC INCLUDES: H3, H12, H13, H14 AND H15

HSS-TMH INCLUDES: H8, H9, H14, H15, H16, H17, H18, H19 AND H20



DETAIL "A"

SCALE 1/2

**FIGURE 7.
HARD SLEEVE
SYSTEM LOCATION
AND DRILLING
INSTRUCTIONS**

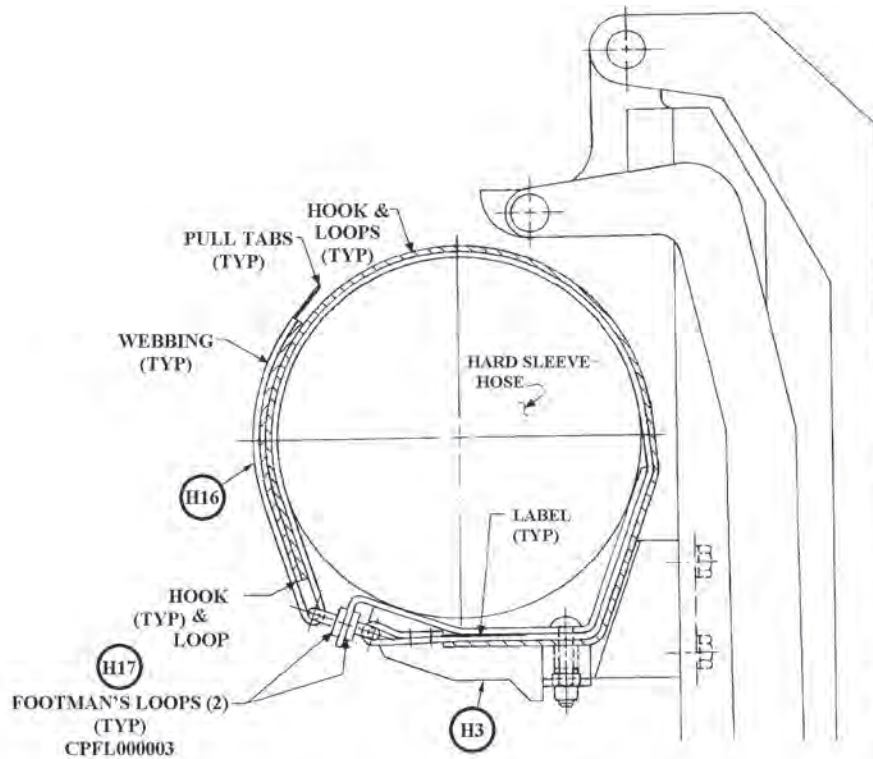

FIGURE 8. QUIC-STRAP SYSTEM TO RETAIN HARD SLEEVE

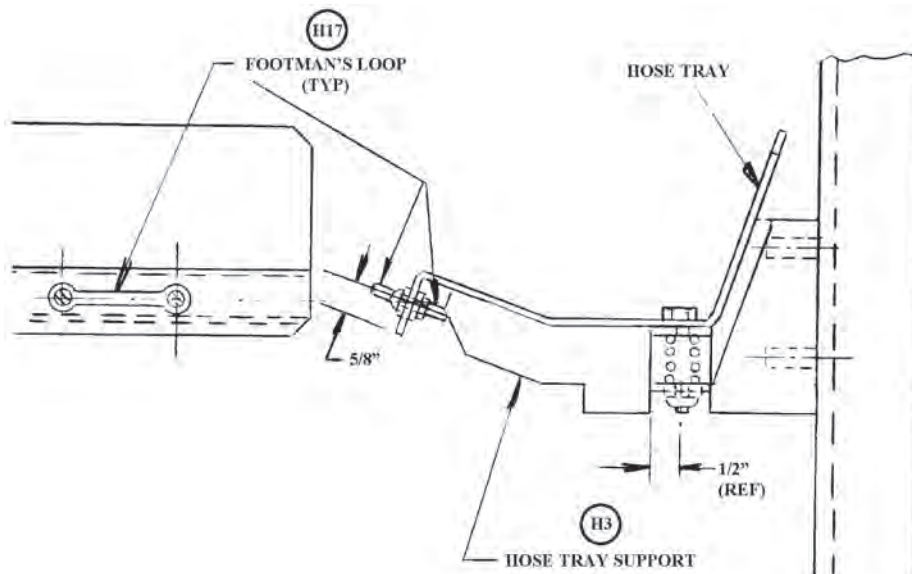

FIGURE 9. HOSE TRAY SUPPORT WITH HOSE TRAY

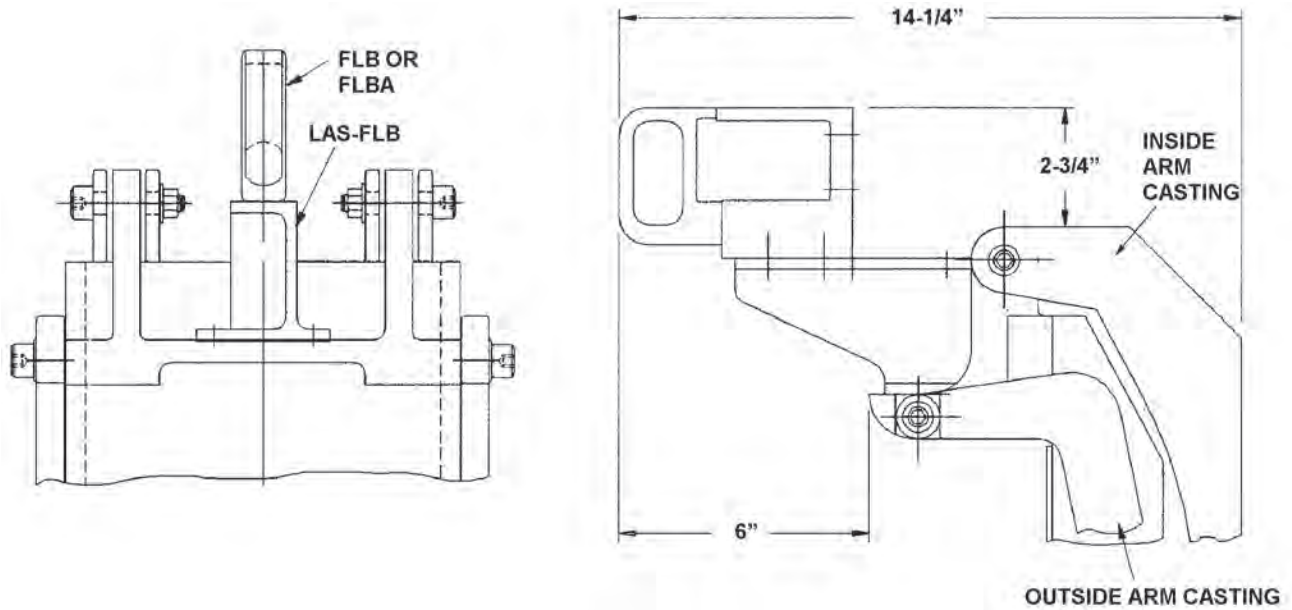

FIGURE 10. MODEL LAS-FLB CASTINGS ATTACHED TO PIVOT SUPPORT CASTING (3097-105-104) WITH MODEL FLB OR FLBA FOLDING LADDER BRACKET CASTING FOR FOLDING ATTIC LADDER

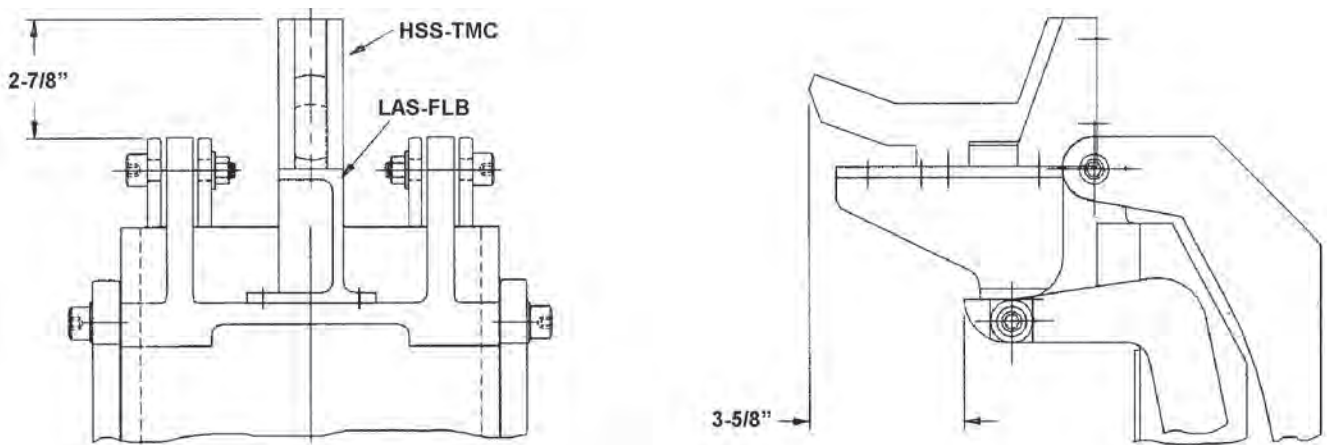
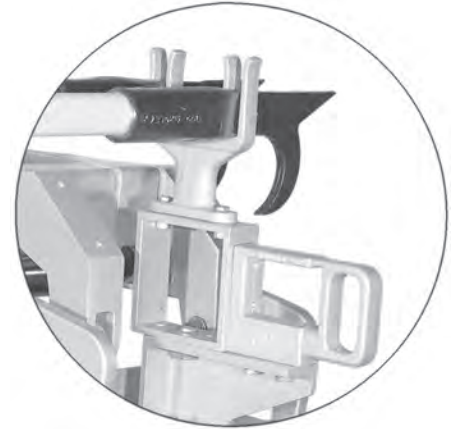
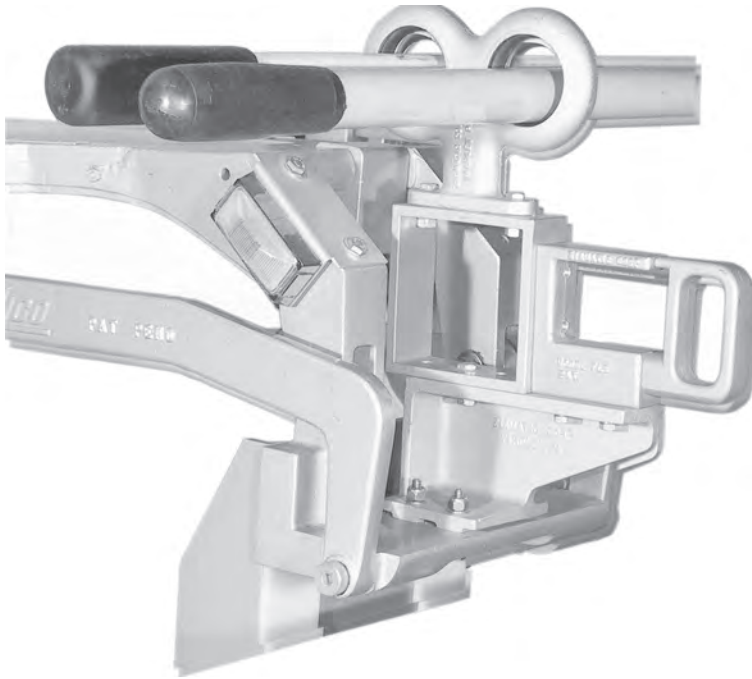
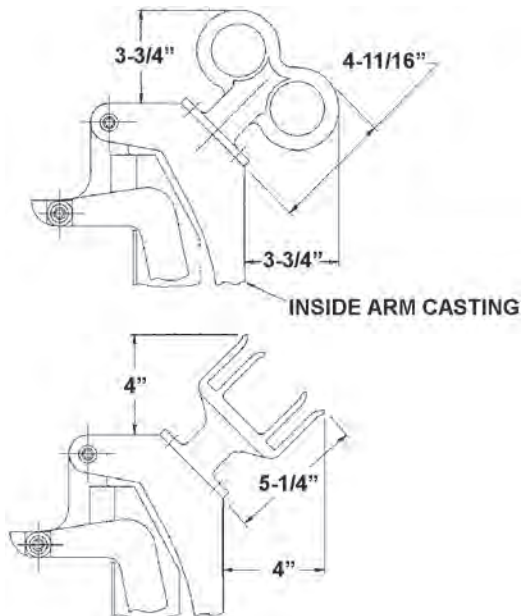
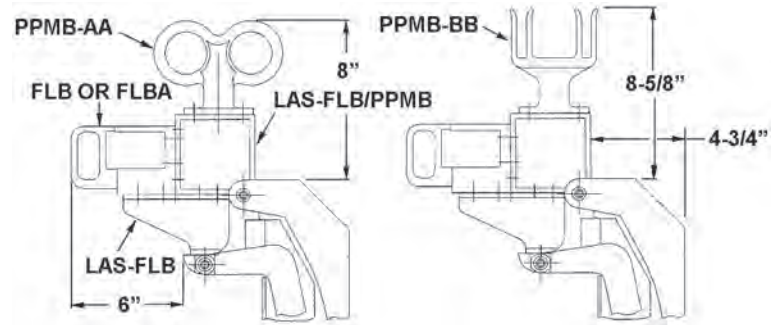

FIGURE 11. MODEL LAS-FLB ATTACHED TO PIVOT SUPPORT CASTING (3097-105-104) WITH MODEL HSS-TMC TRAY MOUNT CASTING FOR MOUNTING OF HARD SLEEVE



**FIGURE 12.
MODEL LAS-FLB/PPMB
EXTRUSION ADDED TO
SUPPORT PPMB-AA
(DOUBLE RING) OR
PPMB-BB (DOUBLE FORK)
PIKE POLE MOUNTING
BRACKET**



**FIGURE 13.
MODEL PPMB-AA (DOUBLE RING)
OR PPMB-BB (DOUBLE FORK)
PIKE POLE MOUNTING BRACKETS
MAY BE ATTACHED DIRECTLY
TO THE INSIDE ARM CASTING
(3097-700-102)**

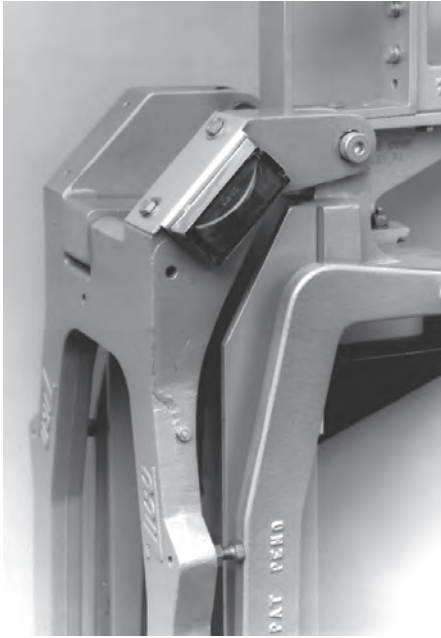

NFPA 1901-96 Standard requires flashing lights be provided, facing front and rear of apparatus. Lights must continue to flash while the device is out of the stored position.

All systems are provided with flashing lights. The audio/visual alarm will continue to be offered as an option (see Section 8000 of Zico product catalog for the audio/visual alarm).

Drilled and tapped holes to mount the light kits will be provided on QUIC-LIFT Systems shipped.



LIGHT KIT COMPONENTS

| MODEL NUMBER | PART NUMBER | DESCRIPTION | WT./KIT IN LBS. |
|--------------|--------------|--------------------|-----------------|
| LAS-HA-FLK | 3097-870-000 | Flashing Light Kit | 1.0 |

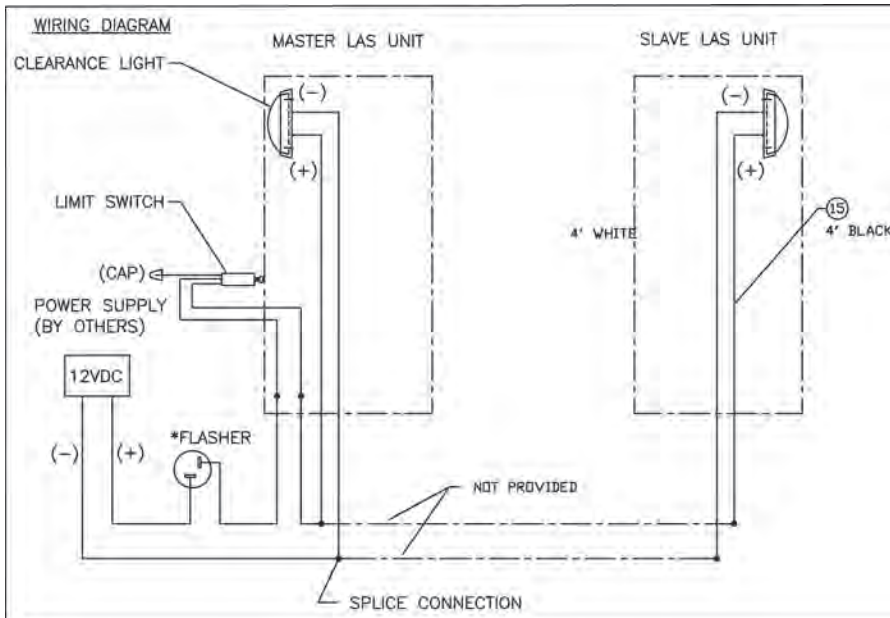

Wiring System:

1. One 2-conductor cable (item 15) is provided for each light (item 1).
2. In-line splices (item 12) are provided. Seventh splice to be connected to third wire in the limit switch (item 3). This wire may be used for indicator light in the cab.
3. Flasher (item 5) should be mounted in a weather-proof location and mounted in the clip (item 17) provided.

FIGURE 14. FLASHING LIGHT KIT MODEL LAS-FLK

| ITEM NO. | PART NUMBER | DESCRIPTION | QTY. |
|----------|--------------|--|------|
| 1 | 3097-270-101 | Clearance Light | 2 |
| 2 | 3097-270-103 | Bracket, Light Mount | 2 |
| 3 | 3097-105-164 | Switch, Limit | 1 |
| 4 | 3098-105-164 | Plate, Limit SW (Ref. Only) | 1 |
| 5 | 3097-270-109 | Flasher | 1 |
| 6 | 9010-221108 | Screw, 4-40 x 1/2 Pan Hd Phillips | 4 |
| 7 | 9012-131100 | Flex Loc Hex Nut 4-40, ZPS | 10 |
| 8 | 9010-102510 | Screw, HH 1/4-20 x 5/8 M/S SZP | 4 |
| 9 | 9014-202500 | Lockwasher, 1/4 Nom. | 4 |
| 10 | 9010-221112 | Screw, 4-40 x 3/4 Pan Hd Phillips | 6 |
| 11 | 3097-270-111 | Cable Tie | 6 |
| 12 | 3097-270-113 | In Line Splice | 7 |
| 13 | 9010-222008 | 10-32 x 1/2" SZP Rnd Head Screw (Ref. Only) | 2 |
| 14 | 3097-870-101 | NFPA Switch Spacer (Ref. Only) | 1 |
| 15 | 3097-270-119 | 16 Ga Lead Wire - Black W/Connector 4 Ft. | 2 |
| 16 | 3097-270-120 | 16 Ga Lead Wire - White W/Connector 4 Ft. | 2 |
| 17 | 3075-175-105 | Delrin Tool Clip | 1 |
| 18 | 3097-270-121 | Fully Ins. Female Push-On Term.; 16-14 AWG; 1/4" W; (Use With Item 5) | 2 |

CHART 3. PARTS LISTING FOR MODEL LAS-HA-FLK

Please make sure all parts are accounted for prior to beginning installation.

The limit switch plate (item 4) has been pre-mounted onto one of the base castings using two #10-32 x 3/8, pan hd screw (item 13).

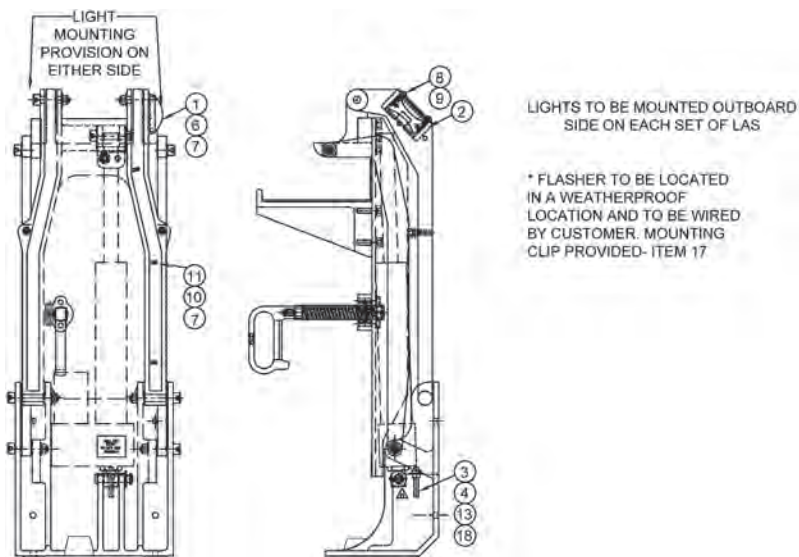

Lights are to be mounted on the outboard side on each set of LAS units.

Limit switch (item 3) makes contact with the actuator to shut off the lights.

*Reflective tape is attached to each ladder mount casting in compliance with NFPA 1901-96.

FIGURE 15. FLASHING LIGHT KIT MODEL LAS-HA-FLK

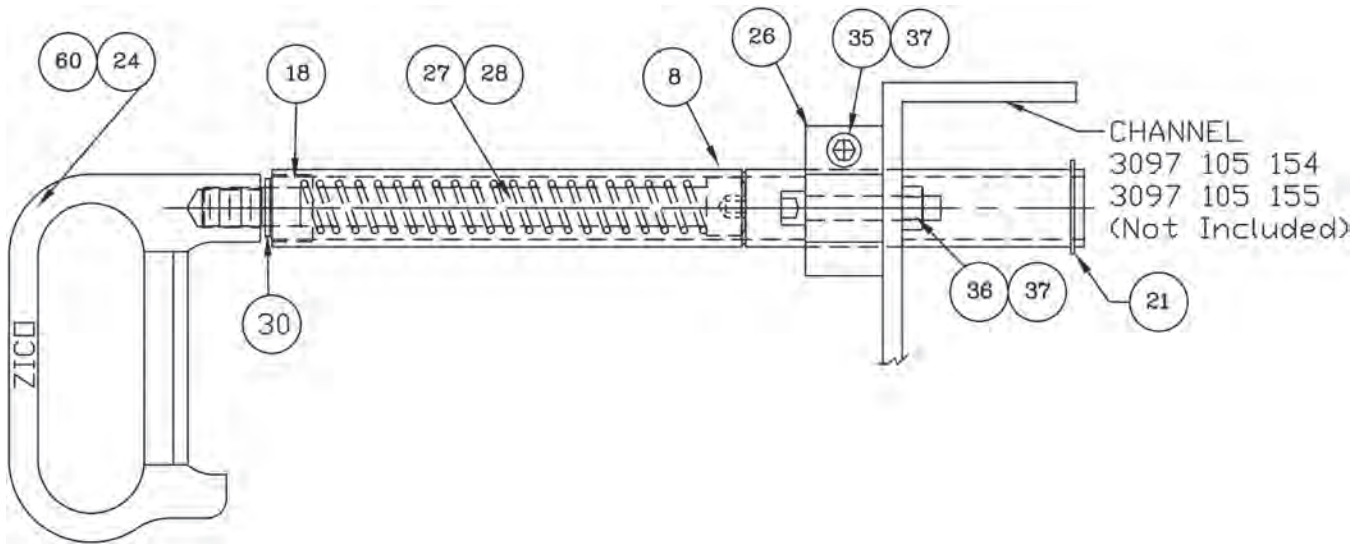

Order 3097-105-910 to receive one complete handle assembly for LAS-HA2-775. For LAS-HA2-975 order 3097-165-910 and for LAS-HA2-1200 order 3097-145-910. Two handles are required per system.

FIGURE 16.
HANDLE ASSEMBLY FOR LAS-HA2 SYSTEMS

| ITEM | PART NAME | PART NUMBER | QTY. |
|------|-------------------------------------|--------------|------|
| 8 | Housing - For LAS-775 | 3097-105-125 | 1 |
| | Housing - For LAS-975 | 3097-165-125 | |
| | Housing - For LAS-1200 | 3097-145-125 | |
| 18 | Set Screw - 7/8-14 Hollow Lock | 3097-105-118 | 1 |
| 21 | Ret. Ring, 1 ϕ Ext. (5100-100) | 3097-105-121 | 1 |
| 24 | Handle | 3097-105-109 | 1 |
| 26 | Support, Retainer Handle | 3095-180-105 | 1 |
| 27 | Screw 1/2-13 x 6 1/2 Socket Hd | 9010-3350104 | 1 |
| 28 | Spring | 3097-105-113 | 1 |
| 30 | Nylon Washer, 1/2 ID x 3/4 OD | 3097-105-130 | 1 |
| 35 | Screw, 5/16-18 x 2 Socket Hd | 9010-333132 | 1 |
| 36 | Screw, 5/16-18 x 2 3/4 Socket Hd | 9018-103128 | 2 |
| 37 | Hex Nut, 5/16-18 Self Lock | 9013-133100 | 3 |
| 60 | Wear Strip | 3097-105-160 | 1 |

For LAS and LAS-BHM Systems purchased prior to January 18, 1999 the channel support (item 54 or 55) will have to be reamed out to use the new handle assembly. The hole must be opened up from .875" to 1.031".

CHART 4.
PARTS LISTING FOR
LAS HANDLE ASSEMBLY

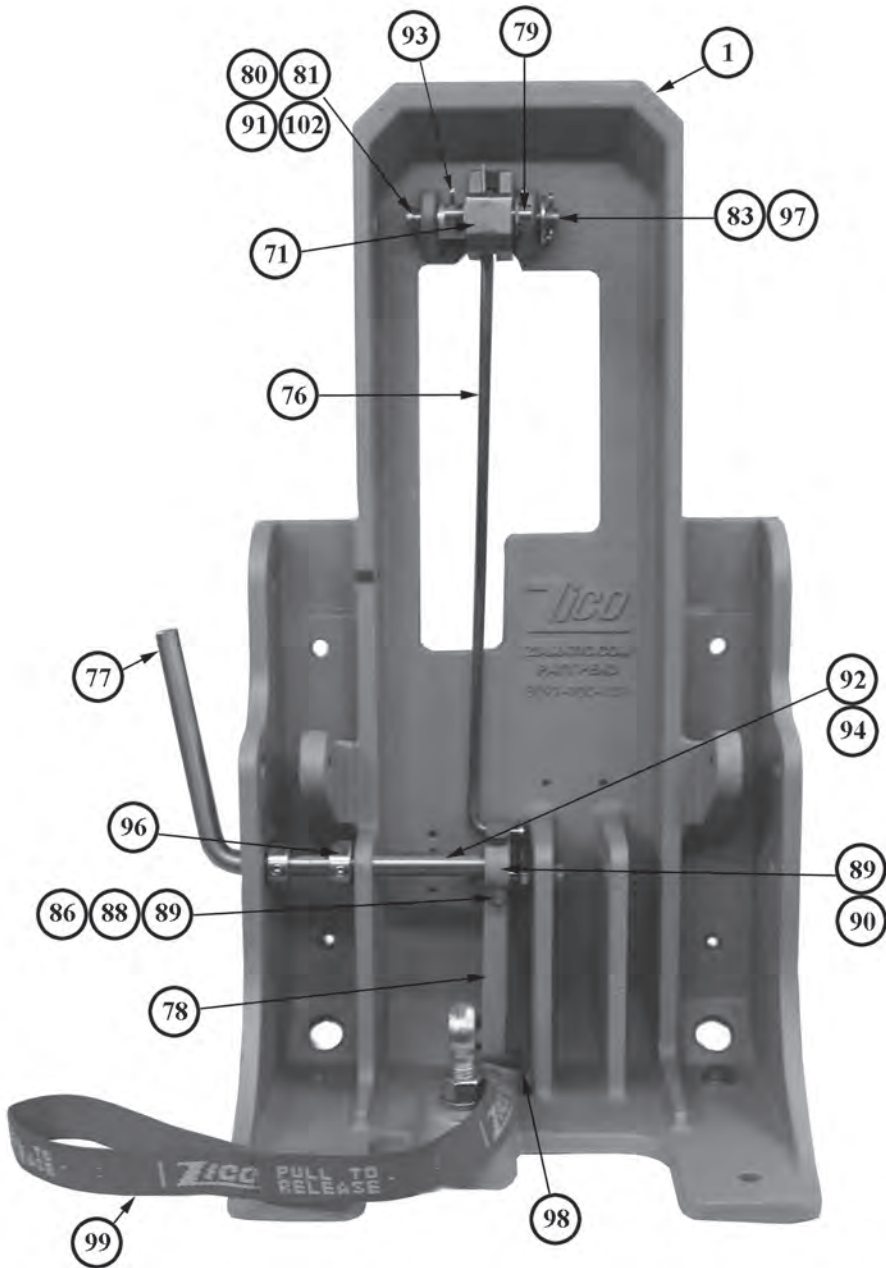

QUIC-LIFT™ Ladder Access Systems are available with either a manual or electric locking system. This page covers the manual system.

The manual locking system provides a positive means of retaining the ladders. The lock must be de-activated prior to operating the electrical control. This is done by pulling outward on the strap (99) or pushing back on the handle (77).

Parts list provided on page 27.

Model LLAS-MLS shown for use with Model LAS-HA2 Systems

**FIGURE 17.
MANUAL LOCKING SYSTEM**

CHART 5. PARTS LISTING MANUAL & ELECTRIC LOCKING SYSTEMS

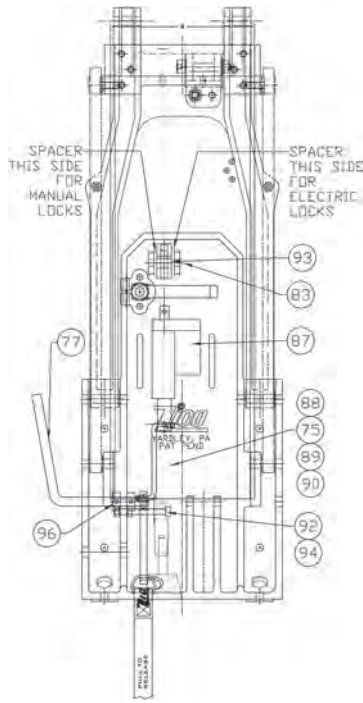

**FIGURE 18.
LOCKING SYSTEM
COMPONENTS**

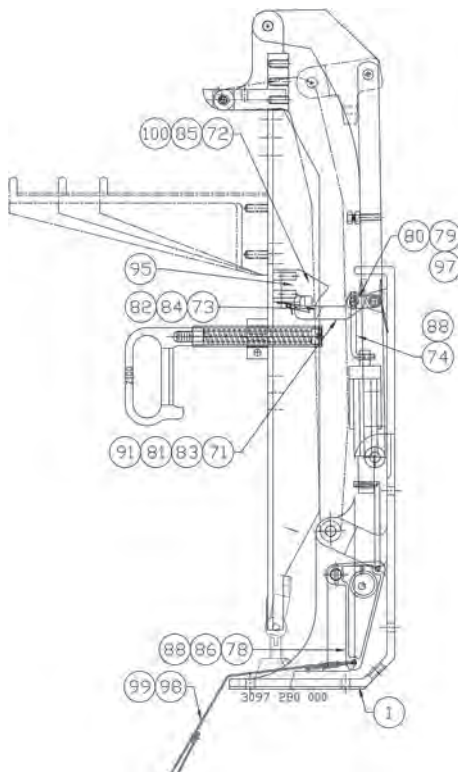

Hook Casting and Latch Keeper Casting Assembly attached to channel support 3097-105-154 or 3097-105-155. Parts 72, 73, 82, 84, 85 & 100.

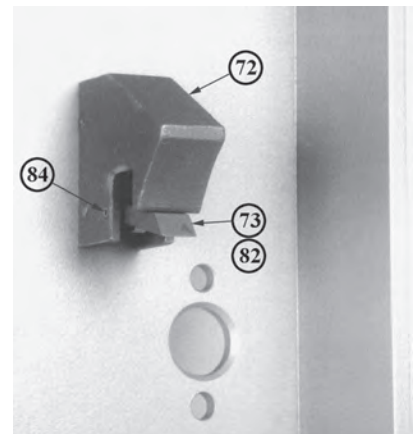

| ITEM NO. | PART NO. | DESCRIPTION | | |
|----------|--------------|------------------------------------|----------|--------|
| | | | ELECTRIC | MANUAL |
| QTY. | QTY. | | | |
| 1 | 3097-900-101 | Base casting for LAS-HA2 | 1 | 1 |
| 71 | 3097-280-103 | Latch casting | 1 | 1 |
| 72 | 3097-280-105 | Hook casting | 1 | 1 |
| 73 | 3097-280-107 | Latch keeper casting | 1 | 1 |
| 74 | 3097-725-103 | Upper rod | 1 | --- |
| 75 | 3097-925-101 | Lower rod | 1 | --- |
| 76 | 3097-920-101 | Manual rod (not shown) | --- | 1 |
| 77 | 3097-920-103 | Handle | 1 | 1 |
| 78 | 3097-280-117 | Crank arm | 1 | 1 |
| 79 | 3097-280-119 | Link pin | 1 | 1 |
| 80 | 3097-280-121 | Link plate | 2 | 2 |
| 81 | 3097-920-105 | Latch spring | 1 | 1 |
| 82 | 3097-280-125 | Keeper spring | 1 | 1 |
| 83 | 9080-004348 | Clevis pin - 7/16 x 3 SZP | 1 | 1 |
| 84 | 9040-101214 | Spring pin - 1/8 x 7/8 | 1 | 1 |
| 85 | 9110-103712 | 3/8-16 x 3/4 HH S/S | 2 | 2 |
| 86 | 9110-102522 | 1/4-20 x 1-3/8 HH S/S | 1 | 1 |
| 87 | 3097-500-185 | Actuator 1" | 1 | --- |
| 88 | 9113-172500 | Nut, self-locking - 1/4-20 Hex S/S | 4 | 2 |
| 89 | 9114-112500 | Washer, plain - 1/4 ID S/S | 4 | 2 |
| 90 | 9070-000608 | Cotter pin - 1/16 x 1/2 | 1 | 1 |
| 91 | 9070-000912 | Cotter pin - 3/32 x 3/4 | 2 | 2 |
| 92 | 9110-103144 | Screw - 5/16-18 x 2-3/4 S/S | 1 | 1 |
| 93 | 3097-920-107 | Lock latch spacer | 1 | 1 |
| 94 | 9113-103100 | Nut - 5/16-18 S/S | 2 | 2 |
| 95 | 3097-920-109 | Hook spacer | 1 | 1 |
| 96 | 3097-280-127 | Shaft collar - 1/2" | 2 | 2 |
| 97 | 9070-001216 | Cotter pin - 1/8 x 1 | 1 | 1 |
| 98 | 0000-000-120 | Key ring - 1" | 1 | 1 |
| 99 | 3097-280-129 | Strap - 1" W x 15" L | 1 | 1 |
| 100 | 9114-203700 | Lockwasher, split - 3/8 ID | 2 | 2 |
| 101 | 3097-285-205 | Control panel assembly | 1 | |
| 102 | 3097-280-131 | Spring installation tool | 1 | 1 |

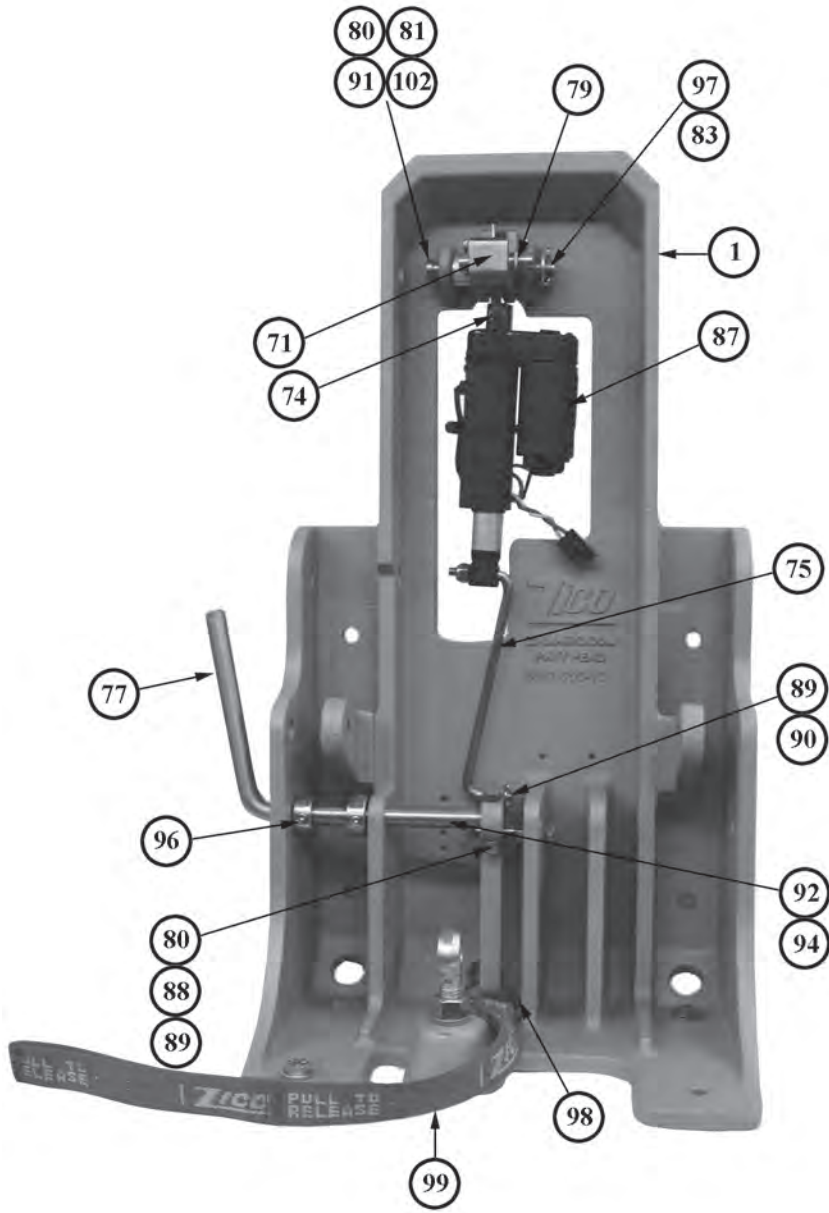

QUIC-LIFT™ Ladder Access Systems are available with either a manual or electric locking system. This page covers the electric system.

The electric locking system provides a positive means of retaining the ladders.

Parts list provided on page 27. For wiring information see pages 29 through 31.

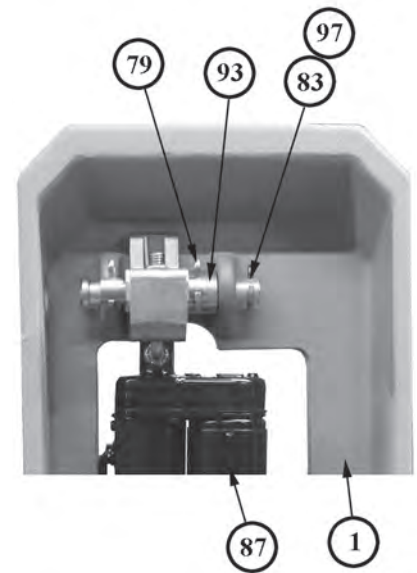

Model LLAS-ELS shown for use with Model LAS-HA2 Systems

Press down on the operating switch and the small electric actuator opens the locking mechanism.
 After a momentary delay, the main electric actuator lowers the system.

**FIGURE 19.
 ELECTRIC LOCKING SYSTEM**

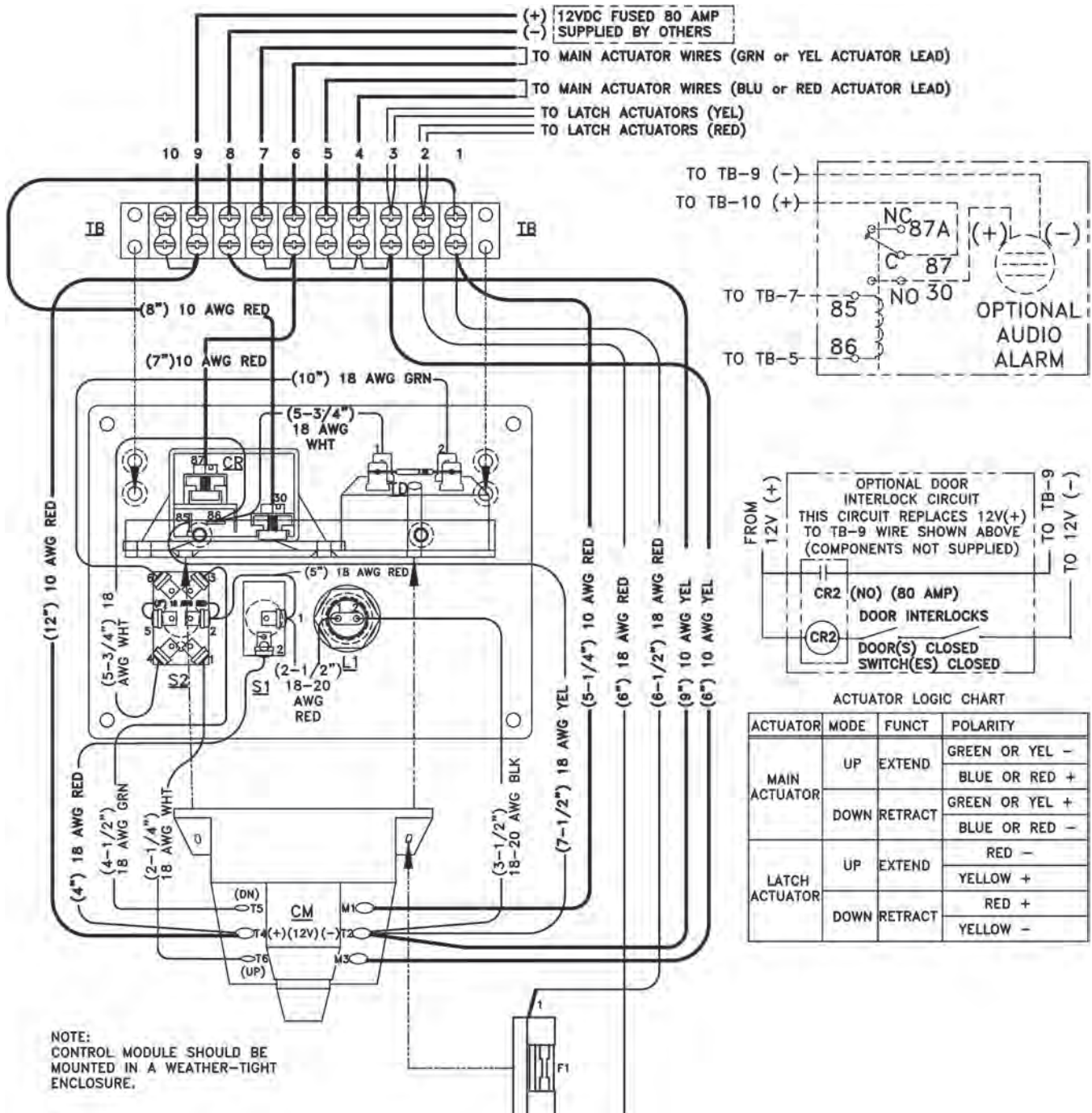

FIGURE 20.
ELECTRICAL SYSTEM
WHEN USING ELECTRIC LOCKS

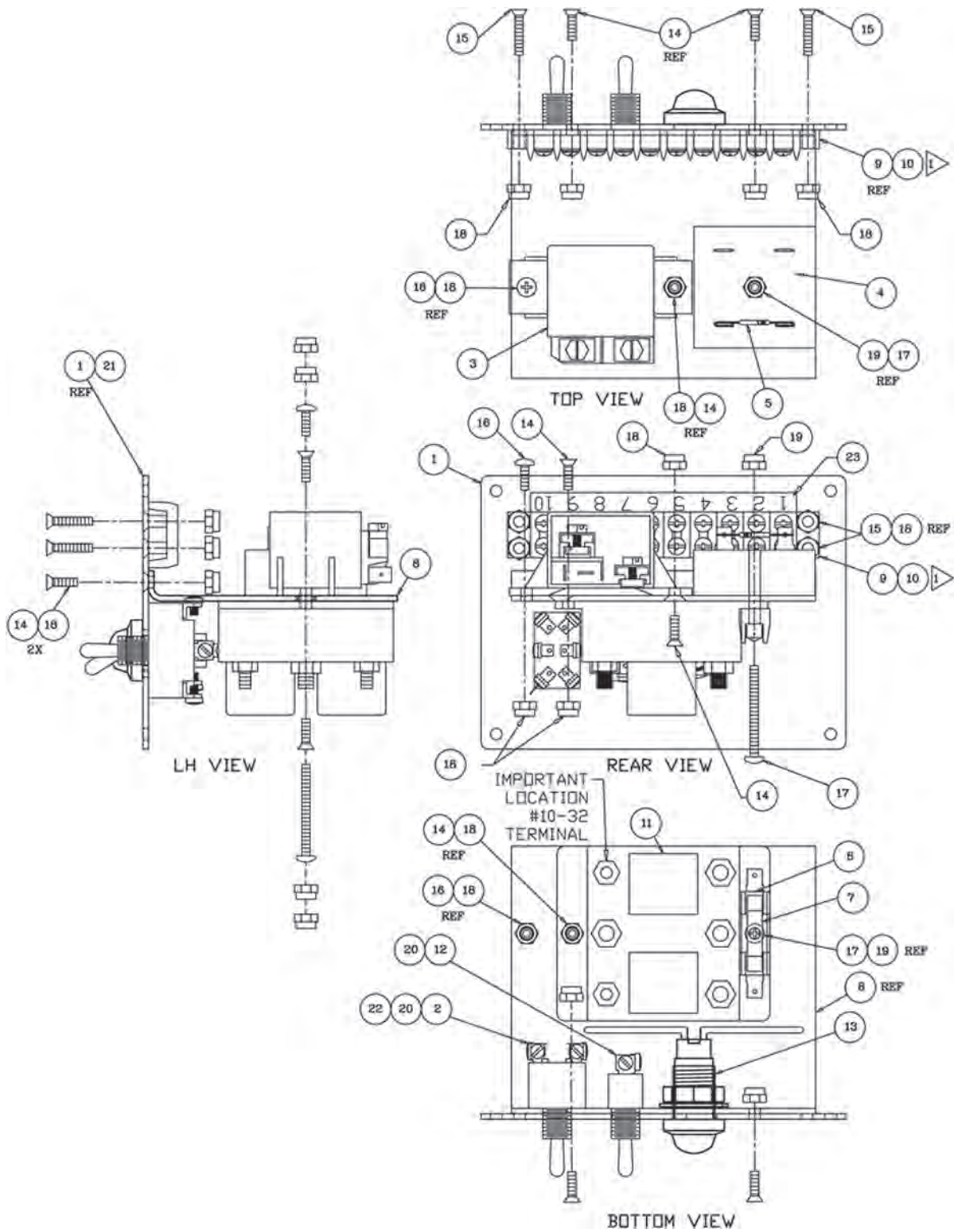

FIGURE 21.
CONTROL PANEL ASSEMBLY

| ITEM NO. | PART NO. | DESCRIPTION | QTY. |
|----------|--------------|---|------|
| 1 | 3097-500-178 | SWITCH MOUNTING PANEL | 1 |
| 2 | 3097-105-144 | SWITCH, DPDT, 3 POS MOM (UP/DOWN) | 1 |
| 3 | 3097-285-119 | RELAY | 1 |
| 4 | 3097-285-121 | TIMER | 1 |
| 5 | 3097-285-123 | RESISTOR | 1 |
| 6 | 3097-285-125 | FUSEHOLDER | 1 |
| 7 | 3097-285-127 | FUSE, 1/4 ϕ X 1-1/4" 15A | 1 |
| 8 | 3097-285-145 | SUB-PANEL | 1 |
| 9 | 3097-285-131 | TERMINAL BLOCK 10 POS | 1 |
| 10 | 3097-285-133 | JUMPER, TERMINAL (NOT SHOWN) | 4 |
| 11 | 3098-400-115 | MOTOR CONTROL UNIT, FWD/REV RELAY | 1 |
| 12 | 3097-500-157 | SWITCH, SPST, 2 POS, (ON/OFF) | 1 |
| 13 | 3097-500-158 | LIGHT, INDICATOR LED, GREEN | 1 |
| 14 | 9110-161608 | 8-32 x 1/2" FLT HD PHILLIPS, SS MACHINE SCREW | 4 |
| 15 | 9110-161612 | 8-32 x 3/4" FLT HD PHILLIPS, SS MACHINE SCREW | 4 |
| 16 | 9110-241612 | 8-32 x 3/4" RND HD PHILLIPS, SS MACHINE SCREW | 1 |
| 17 | 9110-241324 | 6-32 x 1-1/2" RND HD PHILLIPS, SS MACHINE SCREW | 1 |
| 18 | 9113-251600 | 8-32 HEX NUT, LOCK, SS | 9 |
| 19 | 9113-251300 | 6-32 HEX NUT, LOCK, SS | 1 |
| 20 | 3097-105-145 | BOOT, TOGGLE SWITCH | 2 |
| 21 | 3097-500-179 | NAMEPLATE, SWITCH | 1 |
| 22 | 3097-105-146 | LOCKING RING | 1 |
| 23 | --- | LABEL, TERMINAL BLOCK, 1 THRU 10 | 1 |

OPERATING INSTRUCTIONS FOR LLAS-ELS ELECTRIC LOCKING SYSTEM WITH DOOR INTERLOCKS

Note: Refer to the detail "Optional Door Interlock Circuit" on page 31, Figure 22

Mode of Operation

- Turn on power to LAS unit - S2 (by others)
- Close all interlocked doors. (Device will not operate or will stop anytime an interlock is broken.)

Down Mode

- Actuate switch and hold in the down position - (S1).
- the latch actuator will start to unlock the latch, there will be a one (1) second delay after the latch actuator stops to ensure complete latch dis-engagement.
- Ladders will start to move down.
- At full down position release the switch.

Up Mode

- Actuate the switch and hold in the up position (S1).
- Both the lock actuator and main actuators will extend simultaneously.
- Hold the switch until both units have reached full up position (you'll hear ratcheting sound).

In the event the small electric actuator fails to operate, the lock may be de-activated by pulling outward on the strap (99) or pushing back on the handle (77).

NOTE: Relay CR2 for door interlock must be rated 80 amp.



Kit contains one tube of epoxy and two stainless steel rung protectors.

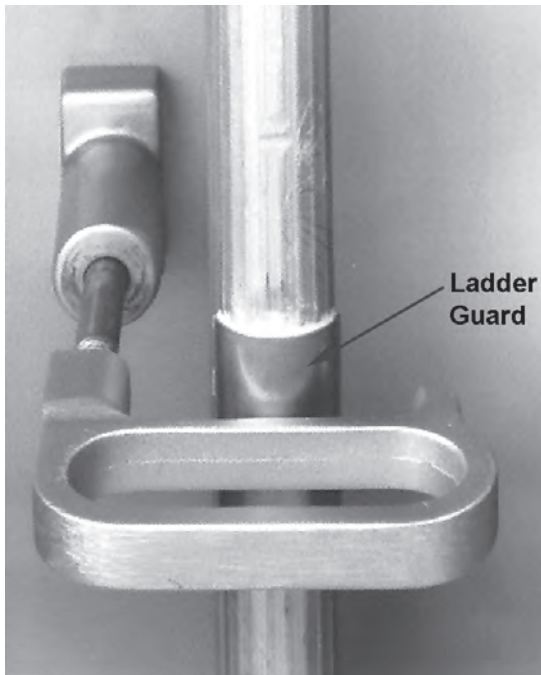

Rung protector installed showing proper placement. Old style handle assembly showing handle retainer casting.

Instructions for Use:

1. Clean rungs with mild soap and water. Let dry.
2. Mark mounting location on rung.
3. Follow instructions for mixing the epoxy.
4. Spread epoxy evenly on the inside of the two rung protectors.
5. Clamp the rung protectors onto the rungs, using light pressure.
6. Let dry for 24 hours.
7. Place back into service.

NOTE: Ladder manufacturer's have kits available to prevent wear of the rungs from contact with the ladder beams. We strongly suggest they be used to extend the life of your ladder.

**FIGURE 22.
LADDER GUARD KIT
MODEL LAS-LGK**

CHART 6. LAS-HA2 PROBLEM SOLVING

PROBLEM:

Units are running out of synchronization.

- * During normal operation, the system should be run until both units have reached the fully lowered position or the fully stored position.
- * Check to make sure the ladders are evenly placed on the system. There should be the same number of rungs hanging off each end of the system.
- * With an electronic tester, measure the voltage just before the actuators. If the voltage differs by 0.5 volts or more, adjustments will have to be made to your wiring.
- * Check the wire to the actuators for proper gauge. Gauge size depends on length of wire. Consult a qualified electrician for gauge size.
- * Wires leading from the power source to each actuator should be the same length within a few feet.
- * Follow the wire path from the power source to the electric actuators. Look for door interlock switches (switches that prevent the unit from operating if a door is open) that are wired directly through the power wire. These switches are rarely rated for the amperage needed to operate the system. This will have a major adverse effect on the system. For most applications 10 gauge wire is sufficient. Power must be run directly to the switch, then directly to the actuator. Switches must be wired using relays rated for at least 75 amps.

SOLUTION:

Implement this into the normal usage of system.

Space ladders evenly or counterweight the lighter side.

See Below

Wire must be replaced if undersized.

Have a qualified technician add wire to the shorter length until they are even.

Have a qualified electrician rewire the system so that the door interlock switches are wired through relays.

WARRANTY REGISTRATION

PLEASE MAIL OR FAX A COPY TO ZICO TO REGISTER YOUR UNIT

FIRE DEPARTMENT NAME: _____ CONTACT PERSON: _____

PHONE NO. _____ FAX NO. _____

STREET ADDRESS: _____ P.O. BOX: _____

CITY: _____ STATE: _____ ZIP: _____

MODEL NO. (CHECK ONE): _____ LAS-HA2 _____ LAS-HA2-975
_____ LAS-HA2-775 _____ LAS-HA2-1200

SERIAL NO. ON UNIT: (SEE PAGE 13 FOR LOCATION) _____

INSTALLED ON: (VEHICLE MFG.) _____ DELIVERED: (DATE) _____

WAS UNIT INSTALLED ON: _____ NEW VEHICLE
_____ RETROFITTED ONTO EXISTING VEHICLE

OPTIONS INSTALLED ON YOUR UNIT (CHECK ALL THAT APPLY):

| | | |
|--------------------|---------------|------------------------|
| _____ LAS-FLB | _____ FLB | _____ LAS-LGK |
| _____ LAS-FLB/PPMB | _____ FLBA | _____ HARD SLEEVE TRAY |
| _____ PPMB-AA | _____ LAS-FLK | _____ OTHER _____ |
| _____ PPMB-BB | | _____ OTHER _____ |

LADDERS MOUNTED ON THE UNIT:

| | |
|---|--|
| DUO SAFETY _____ FT. EXTENSION, MODEL _____ | ALCO LITE _____ FT. EXTENSION, MODEL _____ |
| DUO SAFETY _____ FT. ROOF, MODEL _____ | ALCO LITE _____ FT. ROOF, MODEL _____ |
| DUO SAFETY _____ FT. _____, MODEL _____ | ALCO LITE _____ FT. _____ MODEL _____ |

HARD SLEEVE MOUNTED ON THE UNIT:

_____ FT LIGHT WEIGHT _____ STRAINER ATTACHED TO SLEEVE _____ YES _____ NO
_____ FT STANDARD WEIGHT

WHERE DID YOU HEAR ABOUT OUR PRODUCT?

_____ MAGAZINE AD (SPECIFY) _____
_____ DEALER (SPECIFY) _____
_____ VEHICLE MFG. (SPECIFY) _____
_____ ANOTHER DEPARTMENT (SPECIFY) _____
_____ OTHER (SPECIFY) _____



Ziamatic Corp.

10 West College Avenue, P.O. Box 337, Yardley, PA 19067-0587 • (215) 493-3618 • FAX: (215) 493-1401

www.ziamatic.com

TOLL FREE: 800-711-3473

*ZICO is a registered trademark for fire, safety and marine products made by Ziamatic Corp.

Copyright Ziamatic Corp. 7-18