

# HLAS-OS OPTIONAL STOP

## INSTRUCTIONS:

1. Measure the distance from the rack to the truck body while the unit is in the upright position.
2. If the distance is less than 9", cut the HLAS-OS accordingly keeping the bracket 3" below the top of the truck body.
3. Mount the rubber stops on the end of the L & R brackets using 3/8-16 x 1" hardware that was provided with the HLAS-OS.
4. Place the bracket with the rubber bumper so that the rubber bumper sets against the truck body, and the top of the bracket is flush with the rack.
5. Transfer mounting holes and apply 5/16-18 x 2-3/4" hardware with locknuts. Add washers that were provided.



ITEM #	QTY.	DESCRIPTION	PART NUMBER
1	1	Bracket casting, aluminum R	3097-500-166
2	2	Bracket casting, aluminum L	3097-500-168
3	2	Rubber bumper - 1" H x 2-1/2"	3097-500-160
4	4	5/16-18 x 2-3/4 hex hd c/s	9010-103144
5	4	5/16-18 hex hd flexloc lock nut	9013-133100
6	4	5/16 ID flat washer	9014-113100
7	2	3/8-16 x 1 hex hd c/s	9010-103716
8	2	3/8-16 hex hd flexloc lock nut	9013-133700
9	2	3/8 ID flat washer	9014-113700

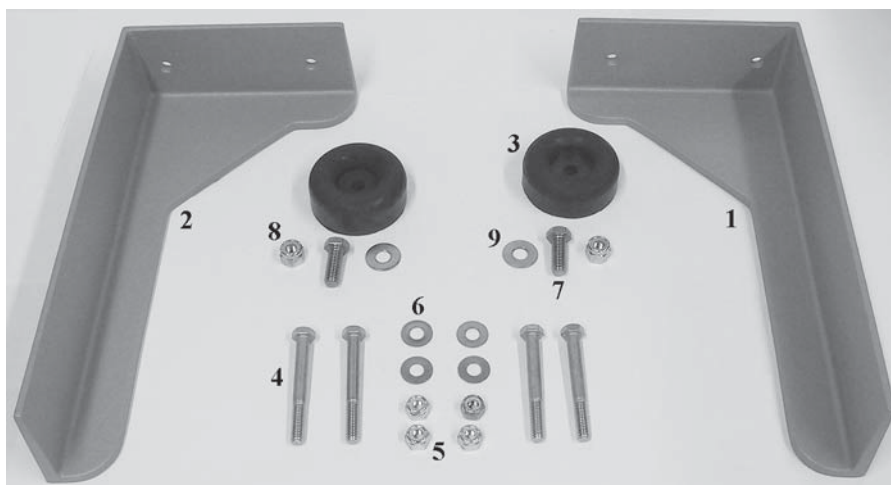

**Ziamatic Corp.**

10 West College Avenue, P.O. Box 337, Yardley, PA 19067-0587 • (215) 493-3618 • FAX: (215) 493-1401

\*ZICO is a registered trademark for fire, safety and marine products made by Ziamatic Corp.

[www.ziamatic.com](http://www.ziamatic.com)

TOLL FREE: 800-711-3473

Copyright Ziamatic Corp. 5-06