

QUIC-LADDER™ SWING OUT & DOWN
VEHICLE LADDER
PARTS AND INSTRUCTION MANUAL



Patent Nos.
 D442,289
 6,378,654

Stores ladder parallel to the body.

Release the locking handle and pull the ladder out to a comfortable climbing angle.

The ladder automatically latches and will not retract until the scissor lock is raised.

Standard configuration has a two-rung fold-down section and a six-rung main ladder section. Other models available to fit your application. Provide us with a rear end dimensional print of your vehicle and we will design a ladder for your application. Ladder can also be mounted to the side of the vehicle.

Cast aluminum rungs have a flat, non-skid surface to provide traction and safety. Each step is 3" deep. Meets NFPA 1901-09 requirements for slip resistance and static load.

The width will vary depending on which of the three styles is used.

MODEL	DESCRIPTION
RL-x-x	Standard 18" Wide Vehicle Ladder
RL12-x-x	12" Wide Vehicle Ladder
RL15-x-x	15" Wide Vehicle Ladder

The x-x will be replaced with number of rungs for each section.

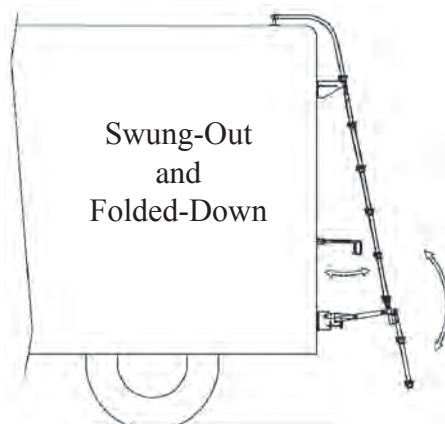
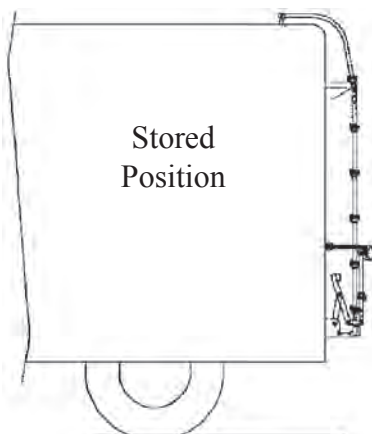

Handrails are 1-1/4" heavy-walled aluminum tubing, covered in a rough grip black powder coat, which provides a firm gripping surface.

ZIAMATIC QUIC-LADDER ORDER FORM

ORDERED BY _____

PO NUMBER _____

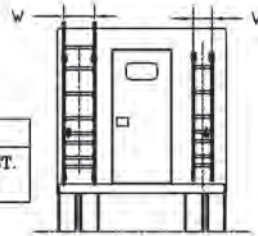

STEP ONE: SELECT ONE BOX FOR LADDER WIDTH

	<input type="checkbox"/>	<input type="checkbox"/>	<input type="checkbox"/>
W	10 3/4" CENTER DIST. (12" MODEL)	13 9/16" CENTER DIST. (15" MODEL)	17 9/16" CENTER DIST. (STANDARD 18")

STEP TWO: SELECT TERMINATION STYLE OF LADDER AND FILL IN THE DIMENSION BOX NEXT TO THE STYLE YOU NEED

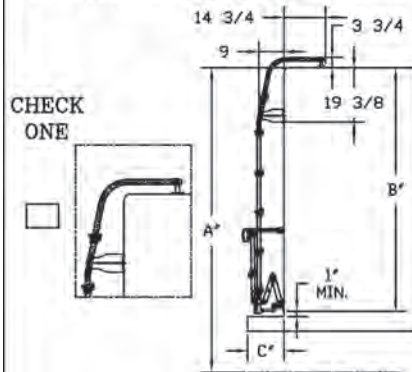

SYM	DESCRIPTION	DIM.(INCHES)
A	GROUND TO TOP OF TRUCK	_____
B	TOP OF TRUCK TO BOTTOM OF LOWER BRACKET (LOWER BRKT. MOUNTS 1 "(MIN) ABOVE BUMPER)	_____
C	BACK OF TRUCK TO REAR OF BUMPER	_____
H	TOP RAIL TERMINATION TO TOP OF TRUCK	N/A

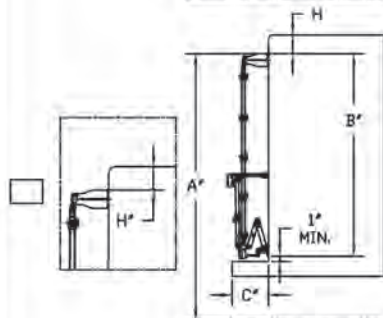

SYM	DESCRIPTION	DIM.(INCHES)
A	GROUND TO TOP OF LADDER	_____
B	TOP OF LADDER TO BOTTOM OF LOWER BRACKET (LOWER BRKT. MOUNTS 1 "(MIN) ABOVE BUMPER)	_____
C	BACK OF TRUCK TO REAR OF BUMPER	_____
H	TOP RAIL TERMINATION TO TOP OF TRUCK	_____

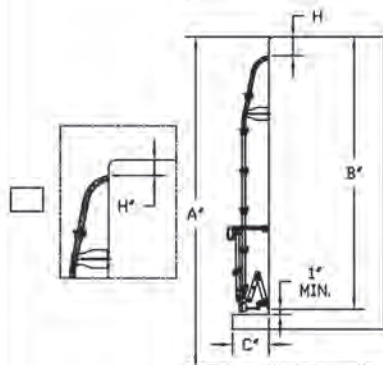

SYM	DESCRIPTION	DIM.(INCHES)
A	GROUND TO TOP OF TRUCK	_____
B	TOP OF TRUCK TO BOTTOM OF LOWER BRACKET (LOWER BRKT. MOUNTS 1 "(MIN) ABOVE BUMPER)	_____
C	BACK OF TRUCK TO REAR OF BUMPER	_____
H	TOP RAIL TERMINATION TO TOP OF TRUCK	_____

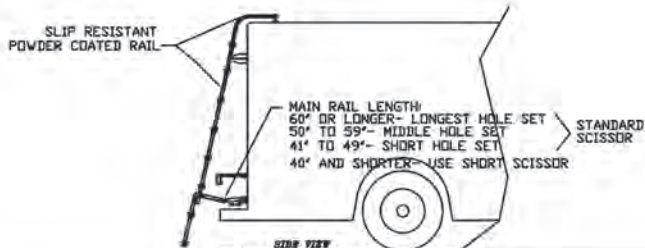

Drawings From Ziamatic

Upon receipt of the customer's dimensions, Ziamatic will provide drawings of the proposed ladder configuration. Customer then places an order and the ladder is custom built to the specifications as shown in the example below.

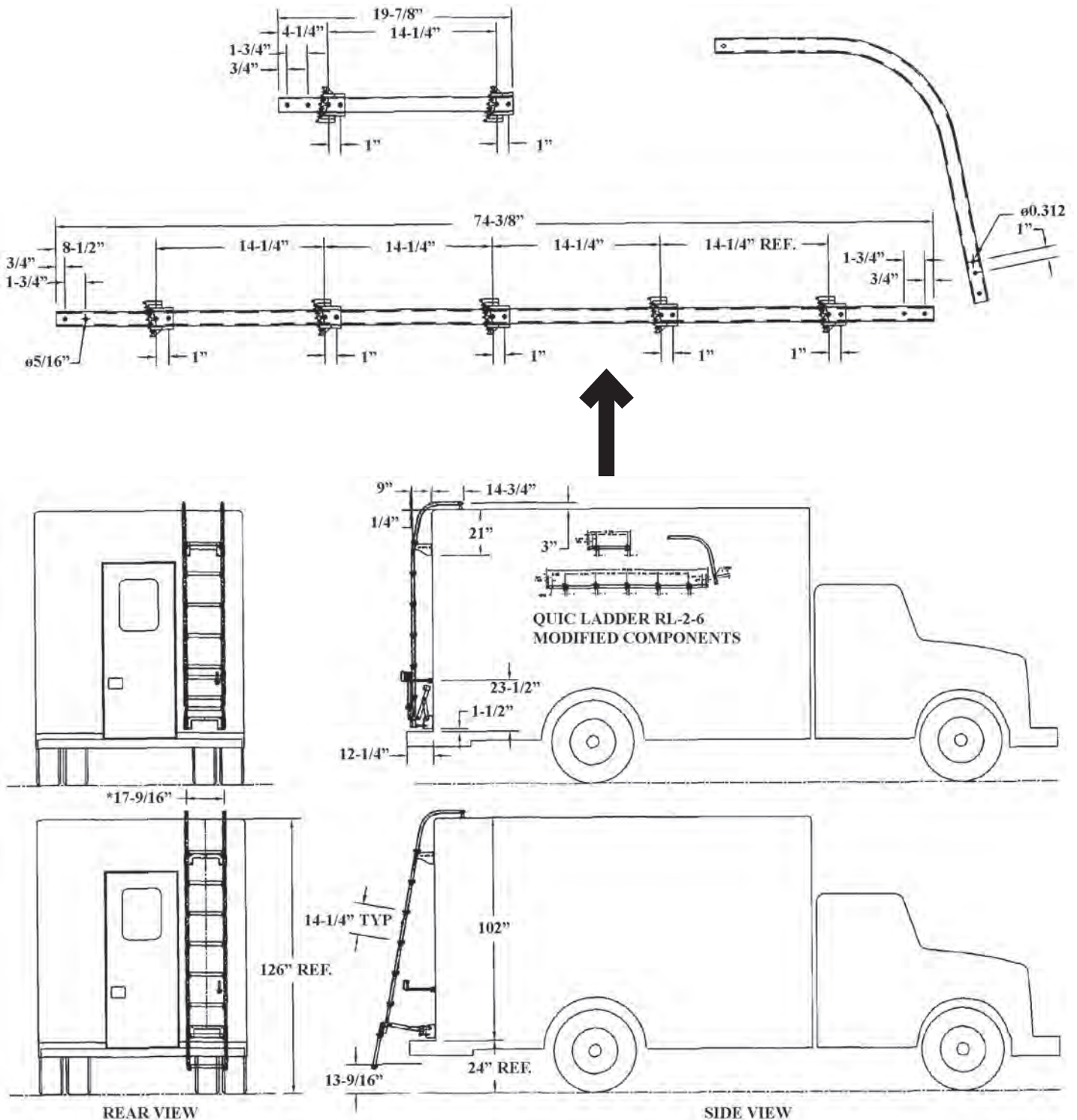

***Dimensions shown are for the standard 18" wide RL-x-x**

ITEM NO.	PART NO.	DESCRIPTION	QTY.
1	3096-005-101	Ladder Rung - Standard 18"	A/R
	3096-200-101	Ladder Rung - 12" Ladder	
	3096-300-101	Ladder Rung - 15" ladder	
2	3096-005-103	Fixed Rail	A/R
3	3096-005-105	Main Rail	2
4	3096-005-107	Folding Rail	2
5	3096-005-109	Lower Joint A	2
6	3096-005-111	Clevis Joint, Male	4
7	3096-055-112	Lower Hinge Bracket	2
8	3096-055-118	Scissor Lock Link, Outbd. (Std. Length)	2
9	3096-055-142	Scissor Lock Link, Outbd. (Short)	
10A	3096-055-136	Upper Bracket, RH (Facing Ladder)	1
10B	3096-055-138	Upper Bracket, LH (Facing Ladder)	1
11	3096-005-121	End Post	2
12	3096-005-123	Clevis Joint, Female	2
14	3096-005-133	Scissor Connector Rod, Std. Ladder	1
	3096-200-133	Scissor Connector Rod, 12" Ladder	
	3096-300-133	Scissor Connector Rod, 15" Ladder	
15	3096-005-125	Bumper, 1" Dia., 3/8-16 Thread	2
16	3096-005-127	Tube Plug	2
17	3096-055-116	Scissor Lock Link, Inbd. (Std. Length)	2
18	3096-055-140	Scissor Lock Link, Inbd. (Short)	
19	3095-180-105	Support, Retainer Handle	1
20	3097-105-109	Handle	1
21	3097-145-125	Housing, Long	1
22	9110-503132	Screw, Button Hd. Sckt Cap, 5/16-18 x 2" Lg. SS	4
23	9113-173100	Nut, Hex., Nylock, 5/16-18 SS	53
24	9110-503136	Screw, Button Hd., 5/16-18 x 2 1/4" Lg. SS	32
25	9110-503128	Screw, Button Hd., 5/16-18 x 1 3/4" Lg. SS	2
26	9180-003727	Pin, Clevis, 3/8 x 1 11/16" (1 15/32 Grip)	6
27	9114-113700	Flatwasher, 3/8ø NOM. SS	14
28	9070-001212	Cotter Pin, 1/8ø x 3/4" Lg. SS	6
29	3097-105-118	Setscrew, Hollowlock, 7/8-14 x 7/16" Sckt, SZP	1
30	3096-005-153	Spring, Compression	1
31	3096-005-135	Sleeve, .385 ID x 5/8" OD x 7/16" Lg.	4
32	9110-103728	Scissor Pivot Screw, 3/8-16 x 1 3/4" Hex Hd., SS	2
33	9180-003732	Pin, Clevis 3/8ø x 2" SS	2
34	9113-173700	Nut, 3/8-16 Hex, Nylock, SS	2
35	9114-203700	Lockwasher, 3/8ø NOM. SS	4
36	9010-3350104	Screw, Socket Head Cap, 1/2-13 x 6 1/2"	1
37	9010-333132	Screw, Socket Head Cap 5/16-18 x 2", SZP	1
39	3097-105-160	Wear Strip, Retainer Handle	1
40	9112-203700	Nut, Hex, 3/8-16 Jam, SS	2
41	9110-313720	Screw, Shoulder, SS 3/8ø x 1 1/4"	2
42	9114-113100	Flatwasher, 5/16ø NOM.	2
43	9110-503124	Screw, Button Sckt Cap, 5/16-18 x 1 1/2"	8
44	3096-005-102	Bottom Rung, Standard 18" Ladder	1
	3096-200-102	Bottom Rung, 12" Ladder	
	3096-300-102	Bottom Rung, 15" Ladder	
45	1045-275-113	Bumper, Rubber	2
46	9125-221910	Screw, S/S Type F Thread Forming 10-24 x 5/8"	2
47	9110-503140	Screw, Button Hd 5/16-18 x 2-1/2" Lg S/S	A/R

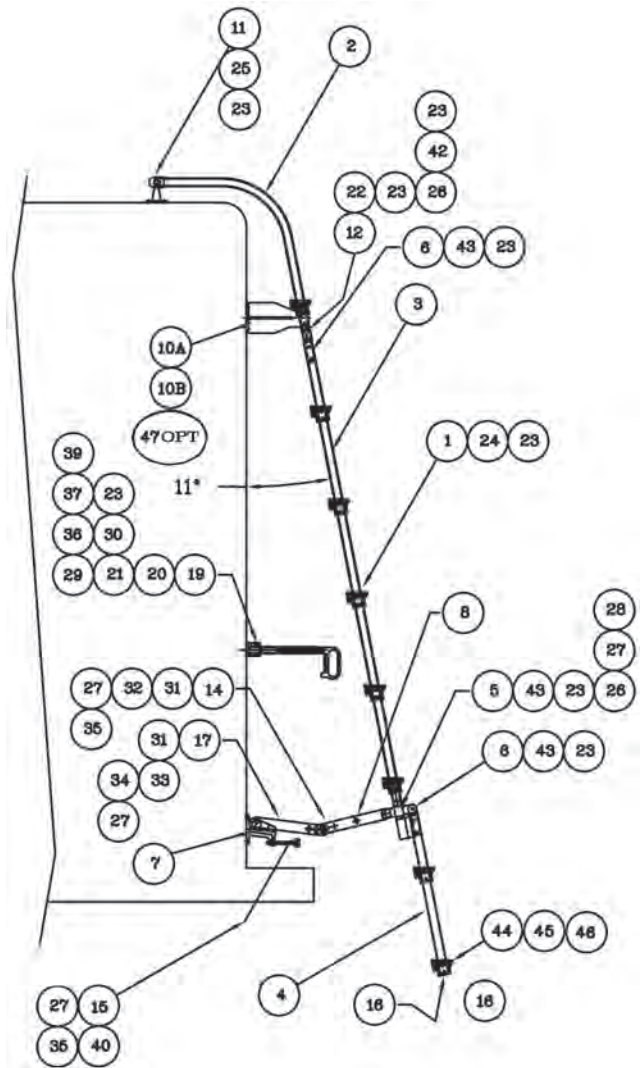

PARTS LISTING

Photos on following pages will reference these item numbers.

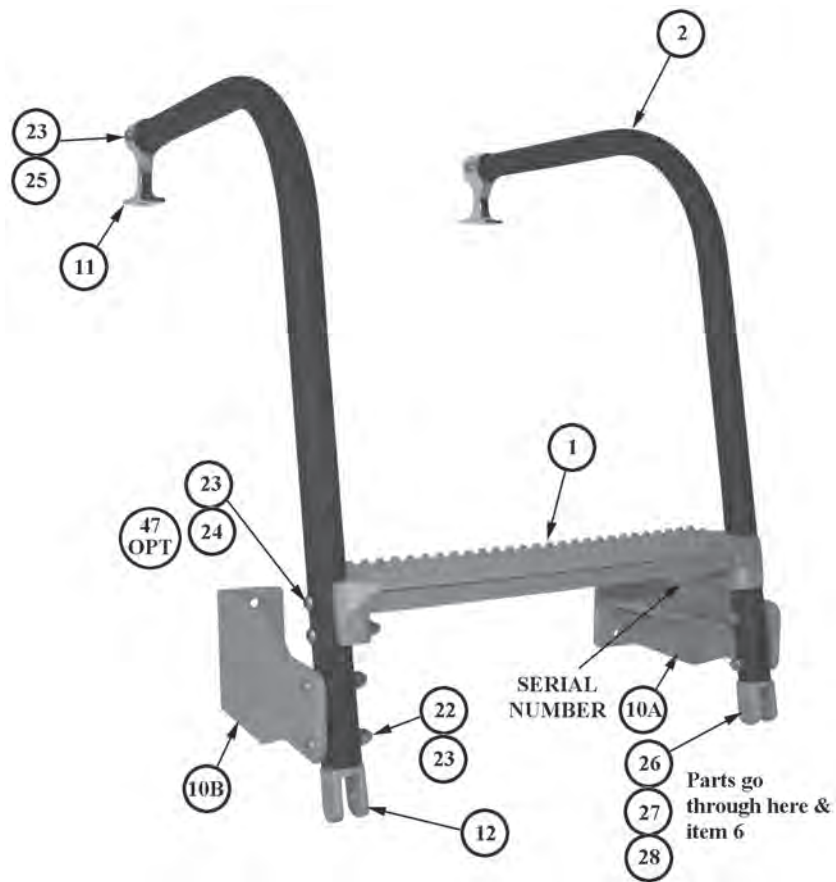
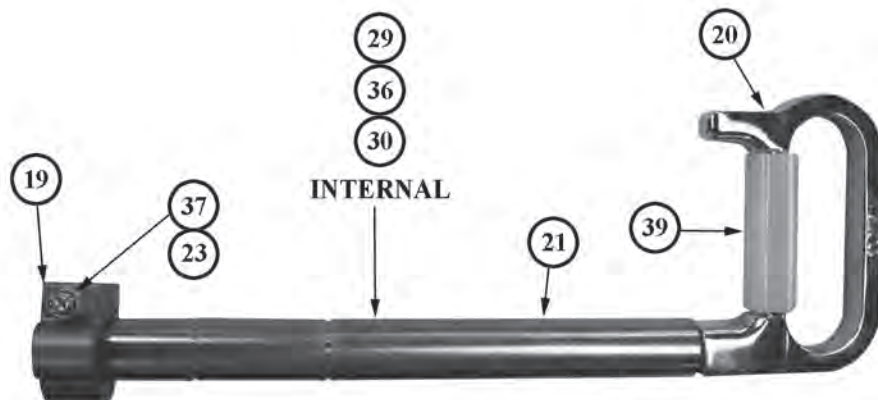

FIGURE 1: UPPER BRACKET AND FIXED RAILS



**FIGURE 2: HANDLE ASSEMBLY
(3096-005-910)**

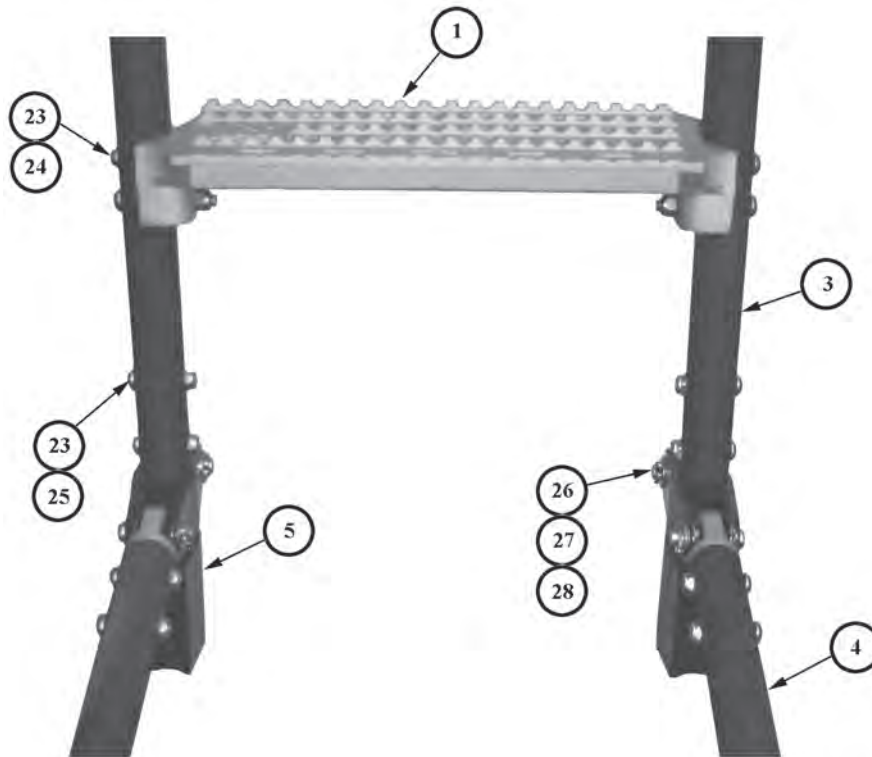

FIGURE 3: FOLDING RAIL (FOREGROUND) ATTACHED TO MAIN RAIL

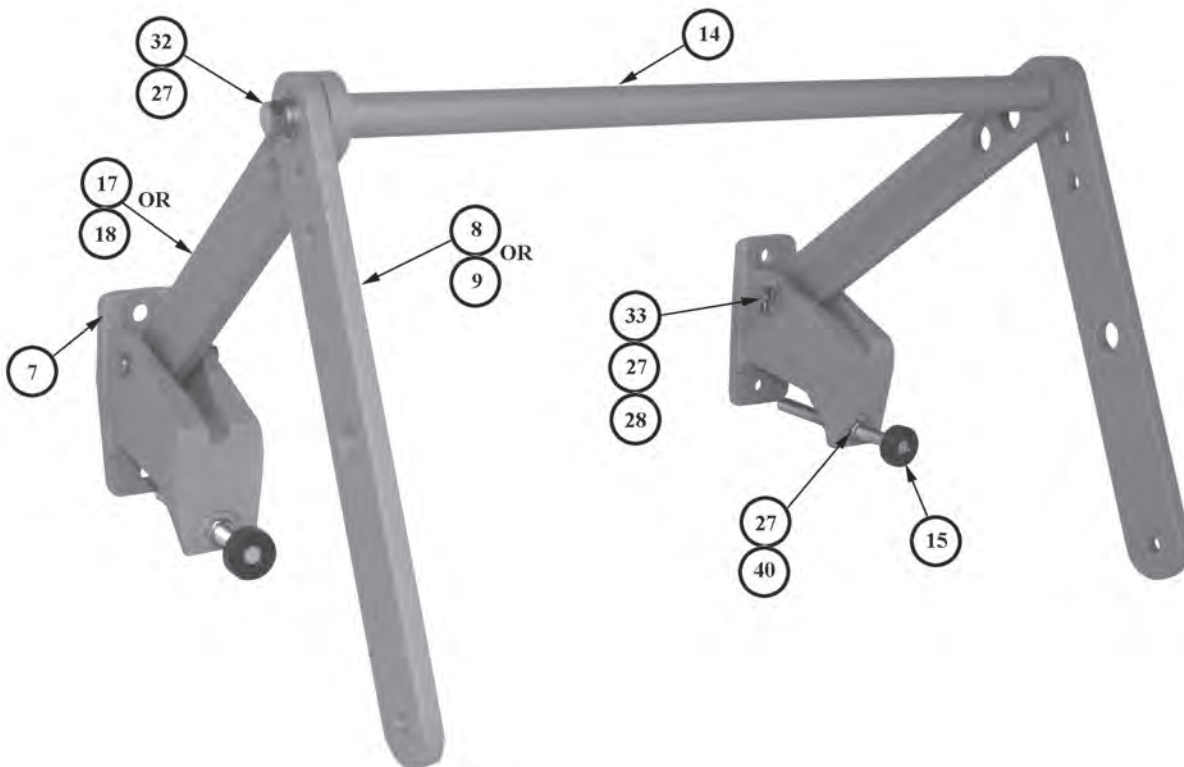

FIGURE 4: LOWER HINGE BRACKET ASSEMBLY

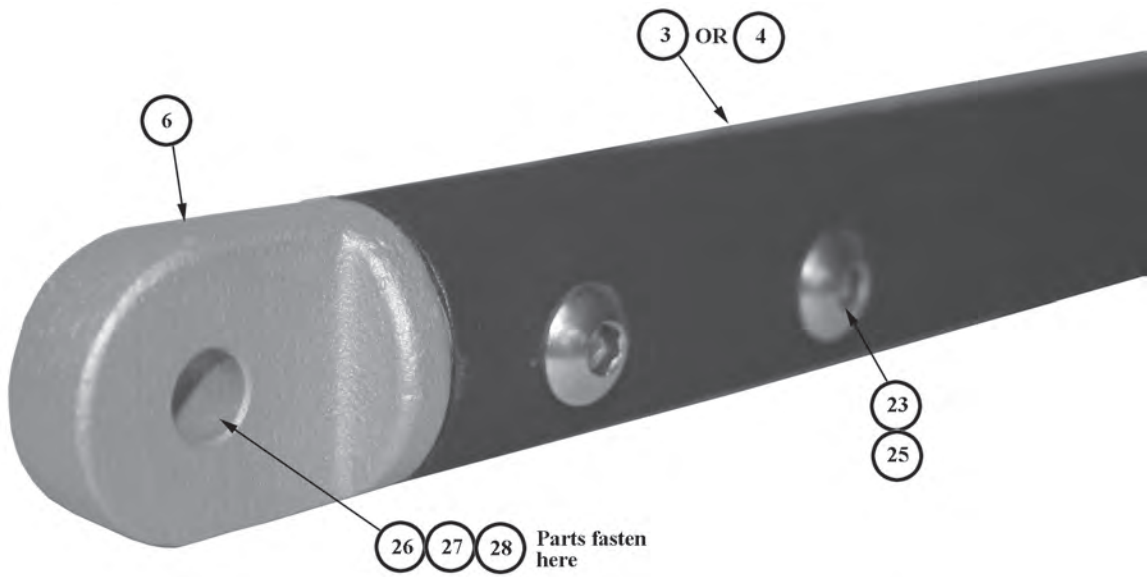

FIGURE 5: CLEVIS JOINT, MALE IN END OF FOLDING RAIL

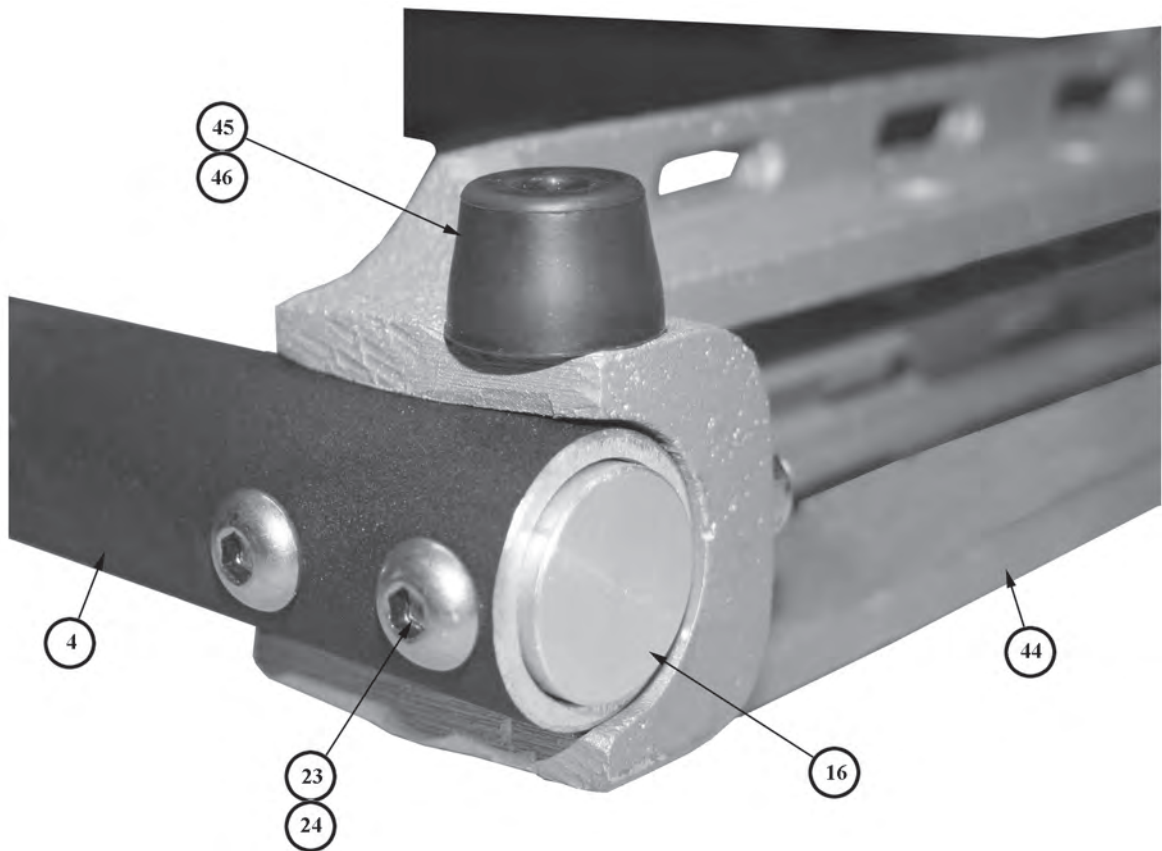
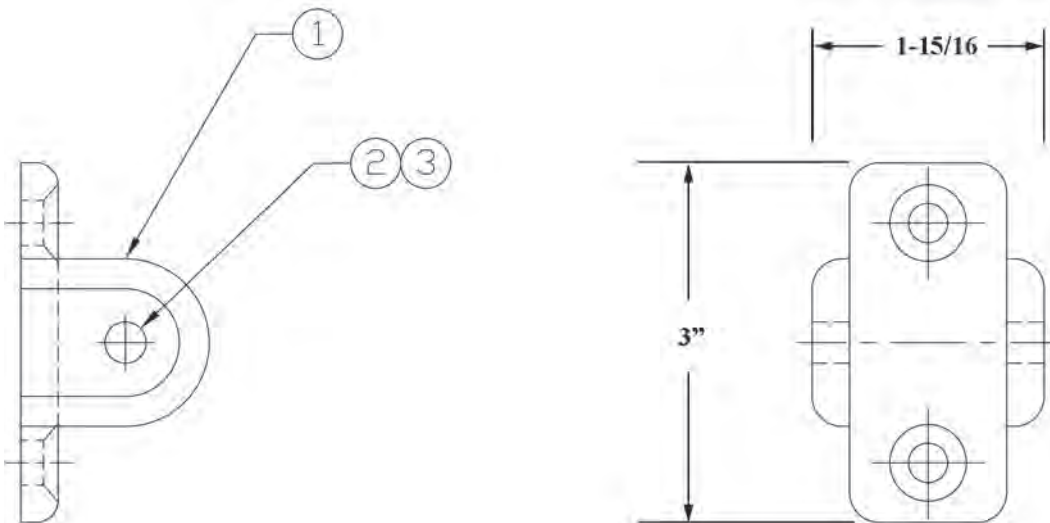

FIGURE 6: TUBE PLUG IN END OF FOLDING RAIL

Optional Equipment - Top End Bracket Assembly

Designed for easier termination to truck body. No welding required.



ITEM #	PART #	DESCRIPTION	QTY
1	3096-090-105	TOP END BRACKET (CASTING ONLY)	1
2	9110-503140	SCREW, BUTTON HD., 5/16-18 X 2 1/2" LG. SS	1
3	9113-173100	NUT, HEX., NYLOCK, 5/16-18 SS	1

Note: Sold individually. For a complete bracket assembly, order Model RL-TEB. Two may be required for application.

Optional Equipment - Splice Rod Assembly

Designed to extend the length of handrails.

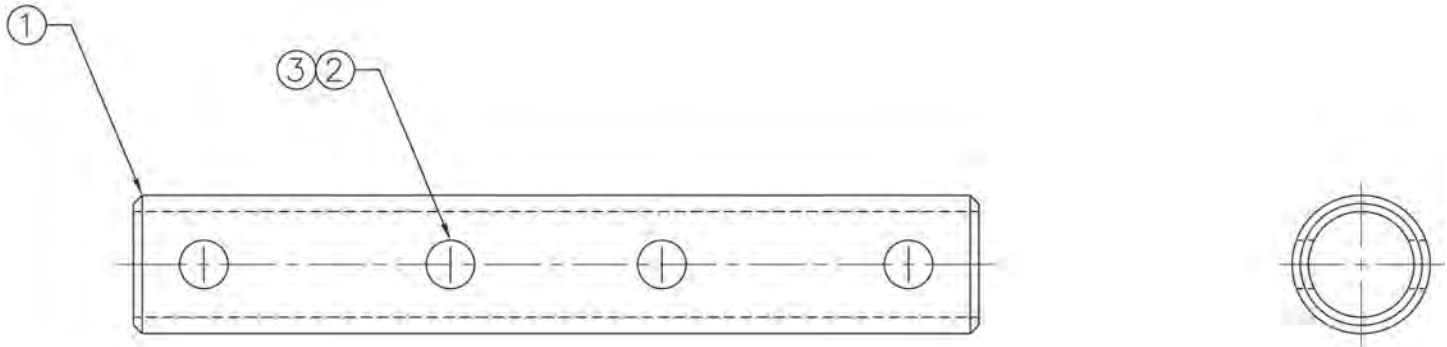

ITEM #	PART #	DESCRIPTION	QTY
1	3096-085-105	SPLICE ROD	1
2	9110-503128	SCREW, BUTTON HD., 5/16-18 X 1 3/4" LG. SS	4
3	9113-173100	NUT, HEX NYLON, 5/16-18 SS	4

Serial Number _____

Please record the serial number for your system here. The serial number may be found on the Upper Bracket (Figure 1, Page 5).

We will require the serial number when you call with any questions pertaining to your ladder system or whenever you are ordering parts.

You may also want to keep a set of the drawings, for your system, with this booklet as shown on Page 3.

Recommended Installation Instructions

1. Before beginning installation, confirm truck dimensions match provided Zico installation drawing. A template is provided for the installation of the mounting brackets. It is suggested in cases where the Quic Ladder is to be installed on thin sheet metal that an additional metal plate should be mounted on opposite side of sheet metal at bracket mounting points to ensure structural integrity of ladder-to-truck attachment.
2. Attach Upper Brackets (Item 10, Figure 1, Page 5) and Fixed Rails (Item 2, Figure 1, Page 5) Assembly and Lower Hinge Brackets (Item 7, Figure 4, Page 6) Assembly to Main Ladder (Item 3, Figure 3, Page 6) Assemble using the hardware provided.
3. Hang assembled Quic-Ladder (in stored position) in desired location on truck.
4. Drill holes to attach End Posts (Item 11, Figure 1, Page 5) to the Fixed Rails (Item 2), if not already done.
5. Assemble to top of truck. In cases where Fixed Rails (Item 2) are not included in order, attach only the Upper Bracket (Item 10) to the truck in this step.
6. Drill holes for Upper Brackets (if not already completed) and Lower Hinge Brackets after locating the proper placement for the brackets. For the locking linkage to function properly the lower hinge brackets must be parallel to one another. The Lower Hinge Brackets should be mounted onto truck so that when the Folding Rail (Item 4, Figure 3, Page 6) is in the stored position, the center linkage hole between the Scissor Lock Link Out (Item 8, Figure 4, Page 6) and the Scissor Lock Link In (Item 17, Figure 4, Page 6) should be about halfway between the Main Ladder and the truck wall. Attach Upper Bracket and Lower Hinge Bracket to the truck.
7. Find proper placement on the truck for the Handle Assembly (Figure 2, Page 5) to ensure support for the Ladder Rung of the Folding Rail in the stored position. Drill holes and attach Handle Assembly to truck.



Ziamatic Corp.

10 West College Avenue, P.O. Box 337, Yardley, PA 19067-0587 • (215) 493-3618 • FAX: (215) 493-1401

www.ziamatic.com

TOLL FREE: 800-711-3473

*ZICO is a registered trademark for fire, safety and marine products made by Ziamatic Corp.

Copyright Ziamatic Corp. 6-17

WARRANTY REGISTRATION

PLEASE EMAIL OR FAX A COPY TO ZICO TO REGISTER YOUR UNIT

EMAIL: SALES@ZIAMATIC.COM FAX: 866-493-1401

FIRE DEPARTMENT NAME: _____ CONTACT PERSON: _____

PHONE NO. _____ FAX NO. _____

STREET ADDRESS: _____ P.O. BOX: _____

CITY: _____ STATE: _____ ZIP: _____

UNIT MODEL NO.: _____

SERIAL NO. ON UNIT: (SEE PAGE 5 FOR LOCATION) _____

INSTALLED ON: (VEHICLE MFG.) _____ DELIVERED: (DATE) _____

WAS UNIT INSTALLED ON: _____ NEW VEHICLE

_____ RETROFITTED ONTO EXISTING VEHICLE

WHERE DID YOU HEAR ABOUT OUR PRODUCT?

_____ MAGAZINE AD (SPECIFY) _____

_____ DEALER (SPECIFY) _____

_____ VEHICLE MFG. (SPECIFY) _____

_____ ANOTHER DEPARTMENT (SPECIFY) _____

_____ OTHER (SPECIFY) _____