

# VALVE WRENCH BRACKET MODELS QR-VWB AND QR-VWB-W

3030PM29  
REV. 6-25-26

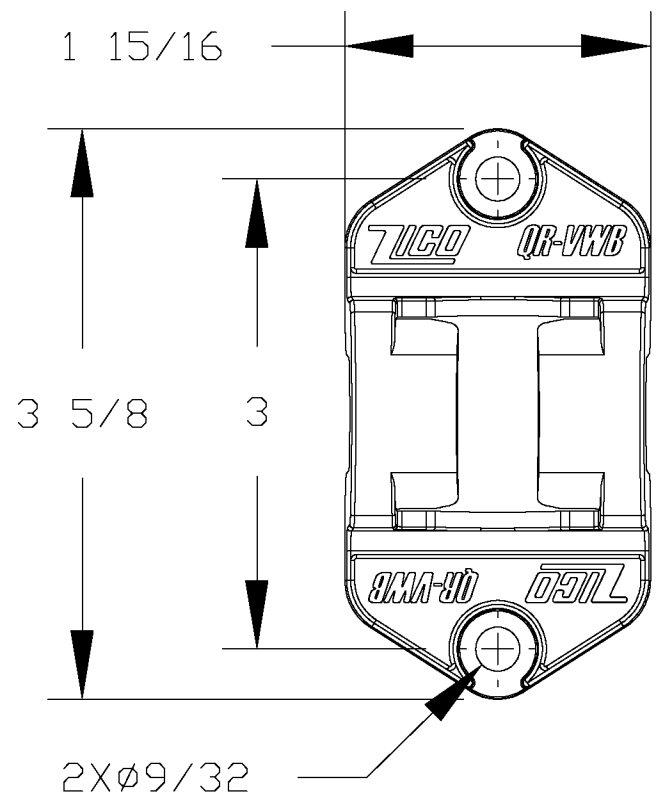
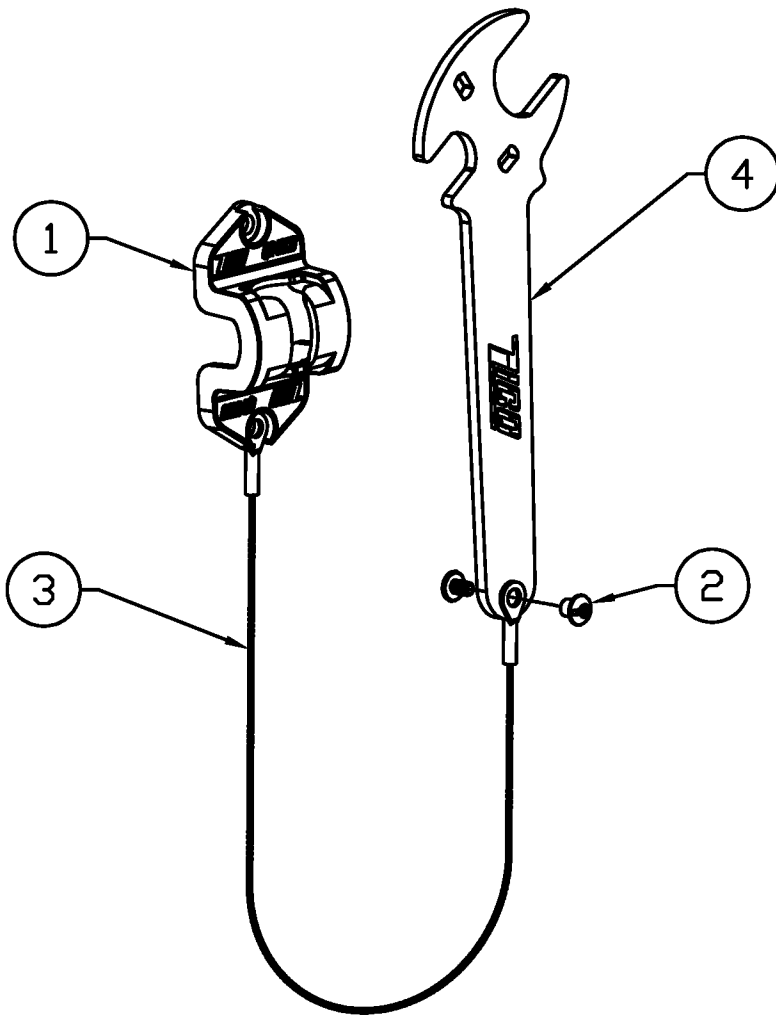

Item	Part Number	Description	Quantity
1	3030-350-105	Valve Wrench Bracket	1
2	3030-350-111	Barrel Screw, Ø1/4 × 3/8 L, ZPS	1
3	3030-350-107	Cable, 20" L, SS	1
4*	3030-350-103	Oxygen Valve Wrench	1

\*Only supplied with model QR-VWB-W

## Attaching cable(2) to your wrench

1. Drill a  $\varnothing 17/32$ " hole  $5/16$ " from the bottom of your wrench for the best fit. See drawing below
2. Place one eye of the cable(2) over the hole and secure with the included barrel screw(3).  
**Blue thread locker is recommended to ensure the wrench does not come loose.**

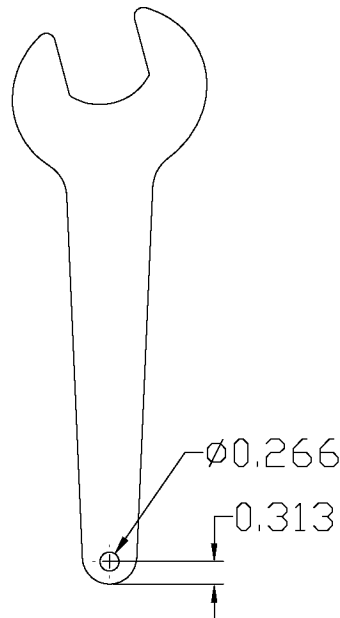

## Mounting Instructions

1. Drill two mounting holes spaced 3" vertically.
  - a. For 1/4-20 nuts and bolts, drill  $9/32$ " clearance holes.
  - b. For #14 tapping screws, drill  $7/32$ " holes.
2. Mount the Valve Wrench Bracket with hardware of your choice.
3. Free end of cable may be placed in line with the bottom mounting hole of the bracket and secured with the same 1/4" hardware.

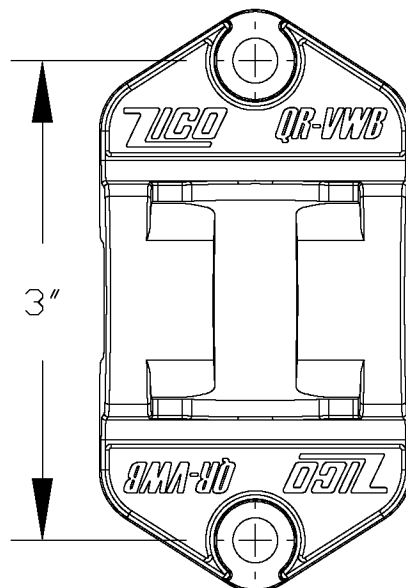

Mounting Hole Spacing

Ziamatic Corp. 10 West  
College Avenue, P.O. Box  
337, Yardley, PA 19067-  
8337

Ph: (215) 493-3618 Fax:  
(215) 493-1401 Toll Free:  
(800) 711-3473 www.  
ziamatic.com

Zico is a registered  
trademark for fire, safety  
and marine products made  
by Ziamatic Corp.

**ZICO**  
Copyright Ziamatic Corp. 12-10