

QUIC-RELEASE® STRAPLESS CYLINDER BRACKET
MODEL QR-D-2
PARTS AND INSTRUCTION MANUAL

3030PM14

Rev. 11-17-16

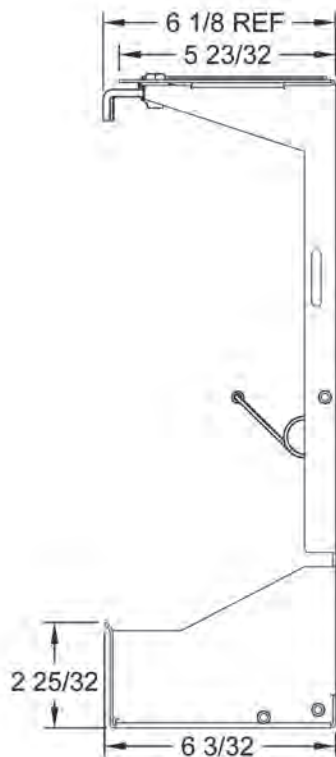
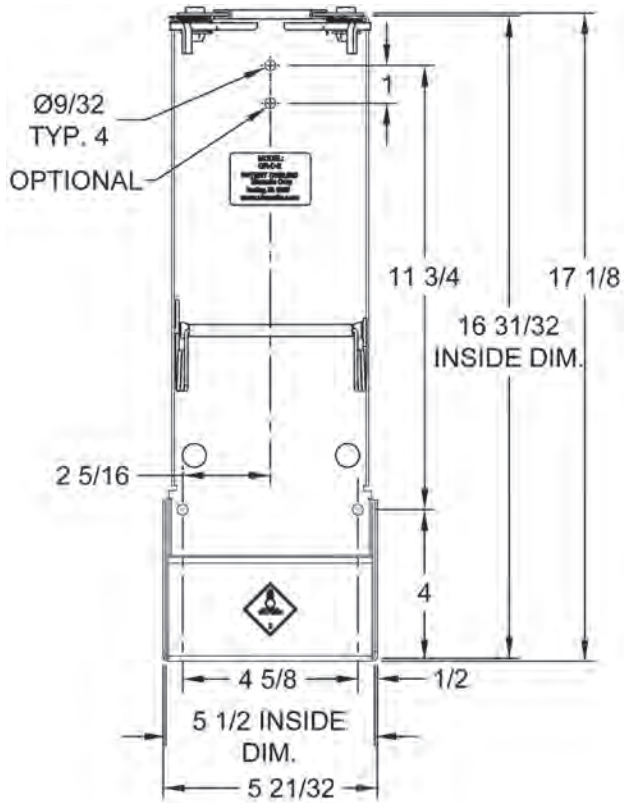

MODEL	DESCRIPTION	WT./@ IN LBS.
QR-D-2	Strapless Cylinder Bracket	5.8

Parts Diagram

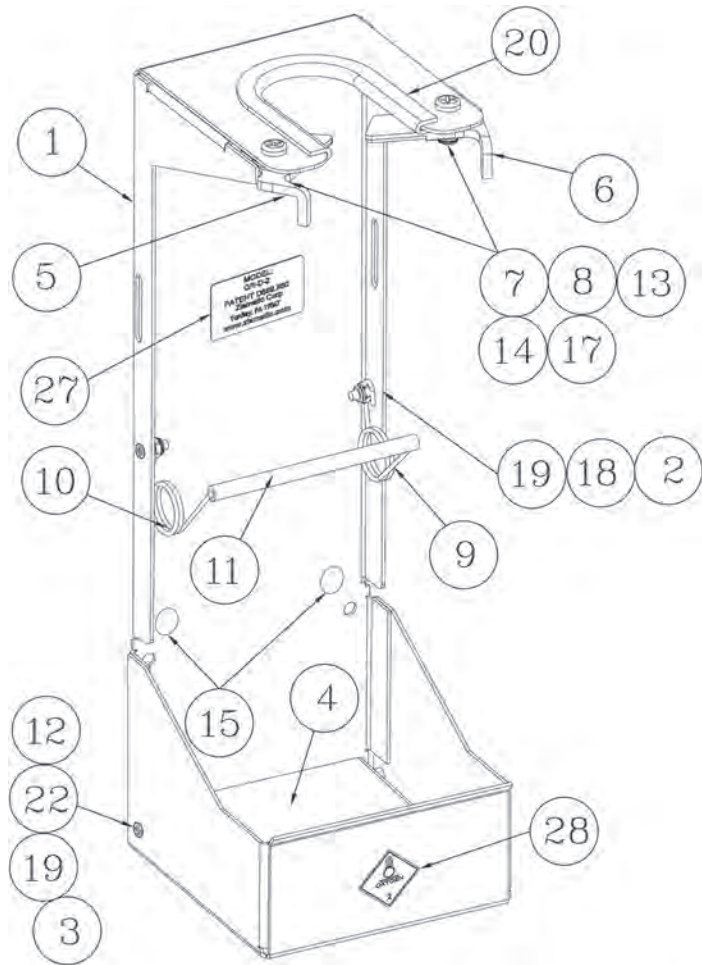

EXPLODED VIEW

ISOMETRIC VIEW

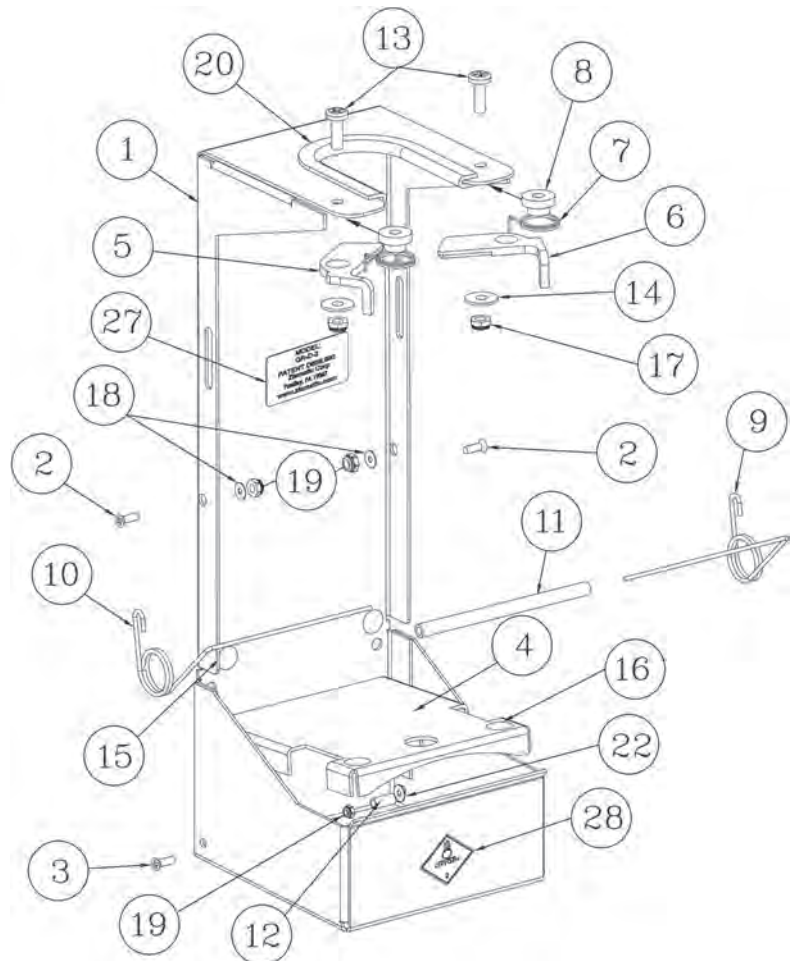

Parts Breakdown

ITEM NO.	PART NO.	DESCRIPTION	QTY.
1	3030-113-101	D-CYL. BRACKET FORM	1
2	9110-361608	#8 x 1/2" FLAT HD, SOCKET HD. S.S.	2
3	9110-361612	#8 x 3/4" FLAT HD, SOCKET HD. S.S.	2
4	3030-113-107	D-CYL. BRACKET SS SPACER	1
5	3030-113-109	D-CYL. BRACKET CAM (LEFT)	1
6	3030-113-111	D-CYL. BRACKET CAM (RIGHT)	1
7	3030-113-113	D-CYL. BRACKET CAM SPRING	2
8	3030-113-115	D-CYL. BRACKET CAM SPACER	2
9	3030-113-117	D-CYL. BRACKET RETURN SPRING RH	1
10	3030-113-119	D-CYL. BRACKET RETURN SPRING LH	1
11	3030-113-121	D-CYL. BRACKET SPRING JACKET	1
12	3030-113-129	SLEEVE .25OD, .186ID, 3/8"L	2
13	9110-352512	BUTTON HD CAP, 1/4"-20 x 3/4 S.S.	2
14	9114-112500	WASHER, 1/4" FLAT S.S.	2
15	3030-113-125	ROUND BUTTON HOOKS	2
16	3030-113-127	ROUND BUTTON LOOPS	2
17	9113-172500	LOW PRO. NUT, 1/4-20, NYLOCK S.S.	2
18	9114-111700	#8 FLAT WASHER, NARROW S.S.	2
19	9113-191700	LOW PRO. NUT, #8, NYLOCK S.S.	4
20	3030-113-123	VINYL EDGE GUARD	1
22	9114-111900	#10 FLAT WASHER, S.S.	2

Operating Instructions

To store standard and steel "D" cylinders:

1. Place cylinder into bracket bottom-first, onto the D-Cyl. Bracket SS Spacer (4).
2. Press cylinder through the bracket cams (5 & 6), until both click into the locked position.
3. Check that the cylinder is now secure against the latches.

To store jumbo "D" cylinders:

1. Flip up the D-Cyl. Bracket SS Spacer (4) and press it against the Round Button Hooks (15) until it remains securely in place.
2. Place cylinder into bracket bottom-first, onto base of the D-Cyl. Bracket Form (1).
3. Press cylinder through the bracket cams (5 & 6), until both click into the locked position.
4. Check that the cylinder is now secure against the latches.

Note: For additional security, extra holes are provided in D-Cyl. Bracket Form (1) to add a strap if desired.

To remove cylinders:

1. Slightly press cylinder against the D-Cyl. Bracket Return Spring Assembly (9 & 10) to relieve pressure on the latch.
2. Squeeze latch handles inward, toward each other, to disengage the latches.
3. Allow D-Cyl. Bracket Return Spring Assembly to push the cylinder free of the latches.

Mounting Instructions

- Mount vertically.
- Brackets may be mounted side by side.
- Minimum of 3 mounting points using 1/4" screws.
- Mounting surface must be able to withstand a pull-out force exceeding strength of screws.



Ziamatic Corp.

10 West College Avenue, P.O. Box 337, Yardley, PA 19067-0587 • (215) 493-3618 • FAX: (215) 493-1401

www.ziamatic.com

TOLL FREE: 800-711-3473

*ZICO is a registered trademark for fire, safety and marine products made by Ziamatic Corp.

Copyright Ziamatic Corp. 11-16