

QUIC-STEP™ RETRACTABLE VEHICLE STEP
MODEL VS-24-11
PARTS AND INSTRUCTION MANUAL

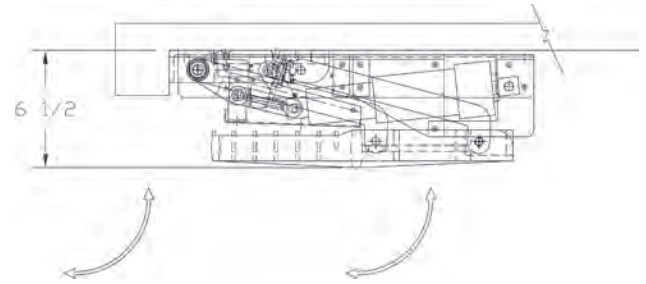

Retracted

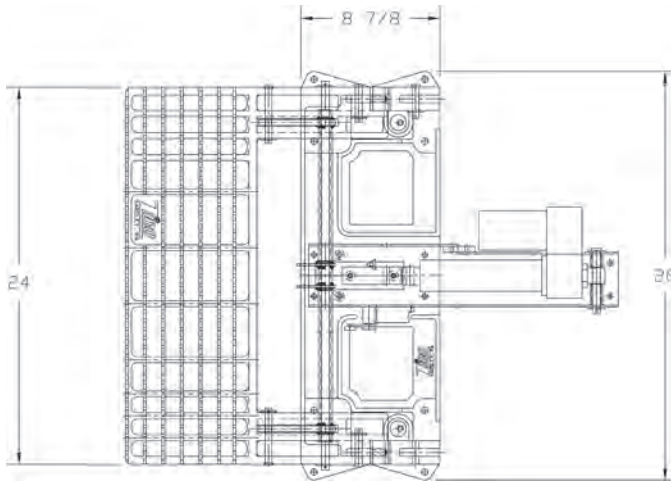
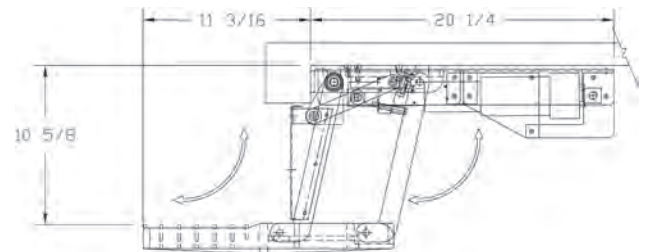

Extended

Designed specifically for use on fire and emergency vehicles. May be retrofitted onto existing apparatus.

Cast aluminum step plate 24" wide x 10-3/4" deep with a non-skid surface to provide traction and safety.



Powered by a single 12-volt electric actuator. Includes a patent pending in-line locking mechanism to hold the extended step rigidly in place.

Step may be wired into door interlock system to automatically extend with door opening and retract with door closing.

Meets NFPA 1901-09 requirements for slip resistance and static load.

MODEL	DESCRIPTION	WT./@ IN LBS.
VS-24-11	Retractable Vehicle Step	71.0

FIGURE 1 - MOTOR CONTROLLER

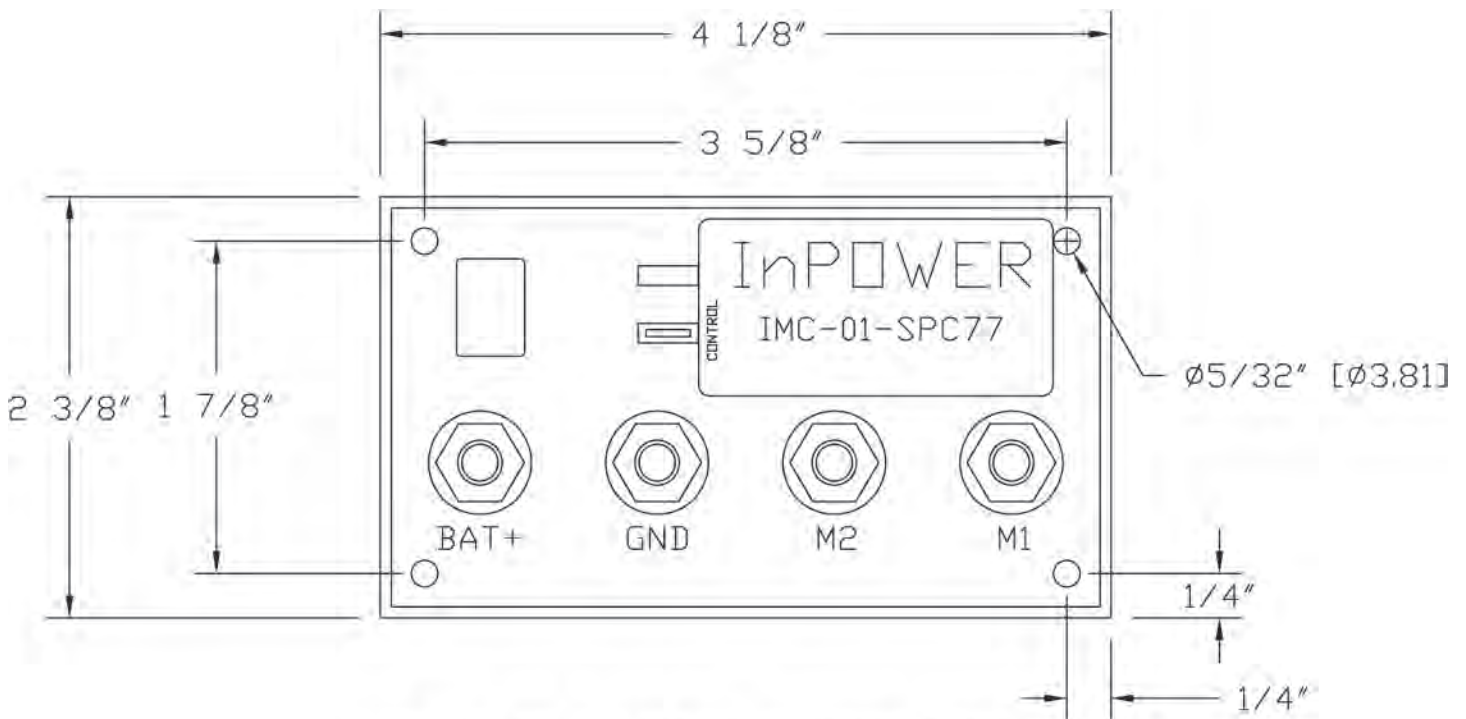

Mount in a weather-tight location

MOUNTING DETAILS

CHART FOR N.C. SWITCH

DOOR	SWITCH	ACTUATOR POL	ACTUATOR	STEP
OPEN	CLOSED	M1 +	M2 -	EXTEND
CLOSED	OPEN	M1 -	M2 +	RETRACT

NOTE: REVERSE ACTUATOR MOTOR POLARITY ON INPOWER MODULE (M1 & M2) IF DOOR SWITCH IS A N.O. SWITCH

CONTROL LOGIC

OPTION: SWITCH FOR STEP 'EXTENDED DOWN'
DASHBOARD STATUS LIGHT

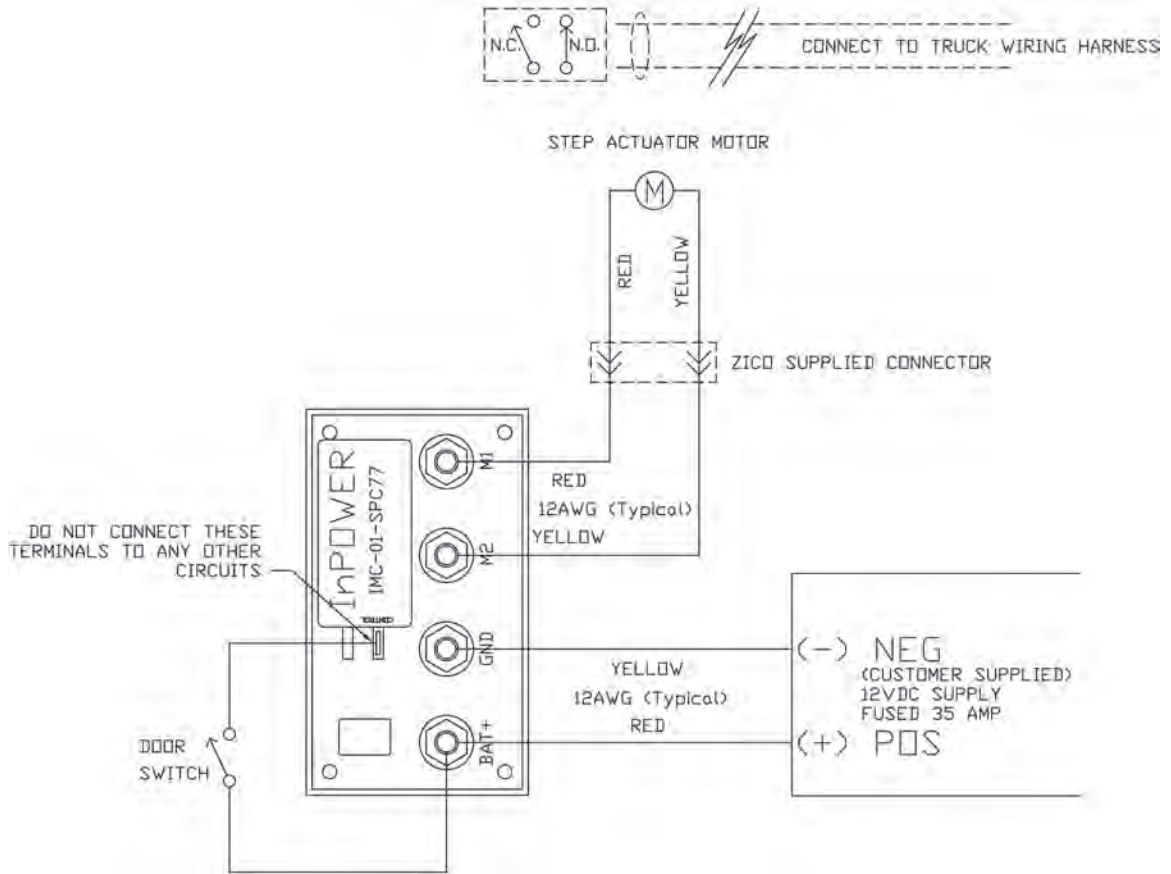

FIGURE 2 - FIELD WIRING DIAGRAM



Note: Switch and electrical panel should be mounted in waterproof compartments. Once all electrical connections are complete and system has been tested, protect connections with a weather proofer like liquid tape.

MODE OF OPERATION

- PROVIDE POWER TO AUTOSTEP

EXTEND MODE:

- STEP WILL AUTOMATICALLY EXTEND AS SOON AS THE DOOR IS OPENED.
- STEP WILL REMAIN EXTENDED AS LONG AS DOOR REMAINS OPEN.

RETRACTED MODE:

- STEP WILL AUTOMATICALLY RETRACT AS SOON AS THE DOOR IS CLOSED.
- STEP WILL REMAIN RETRACTED AS LONG AS DOOR REMAINS CLOSED.

CHART 1

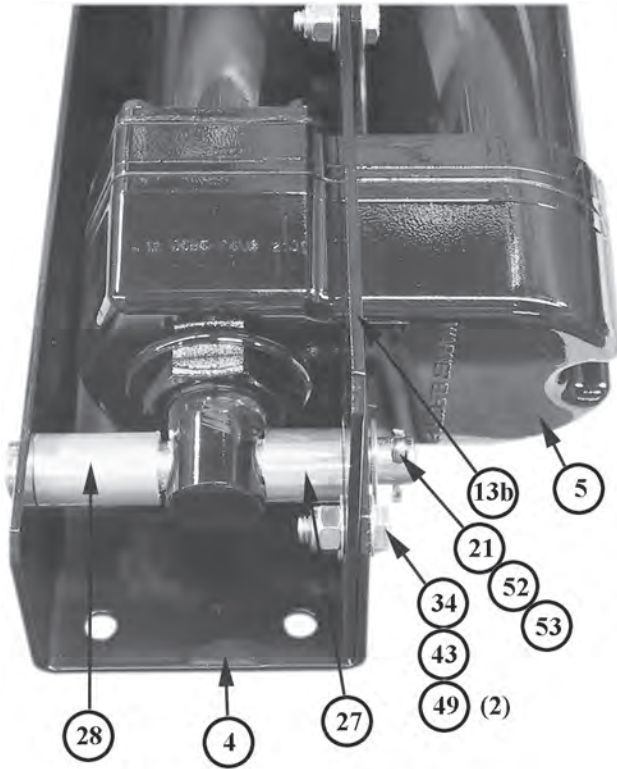

FIGURE 3 - ACTUATOR

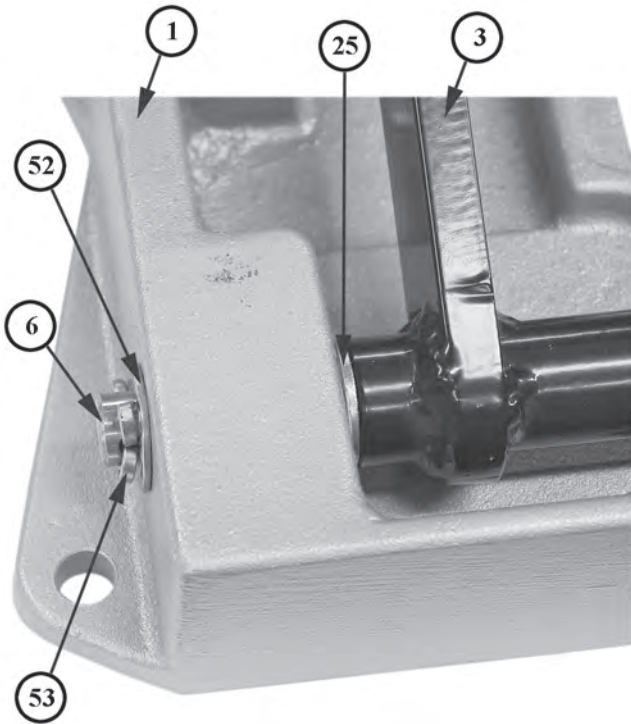
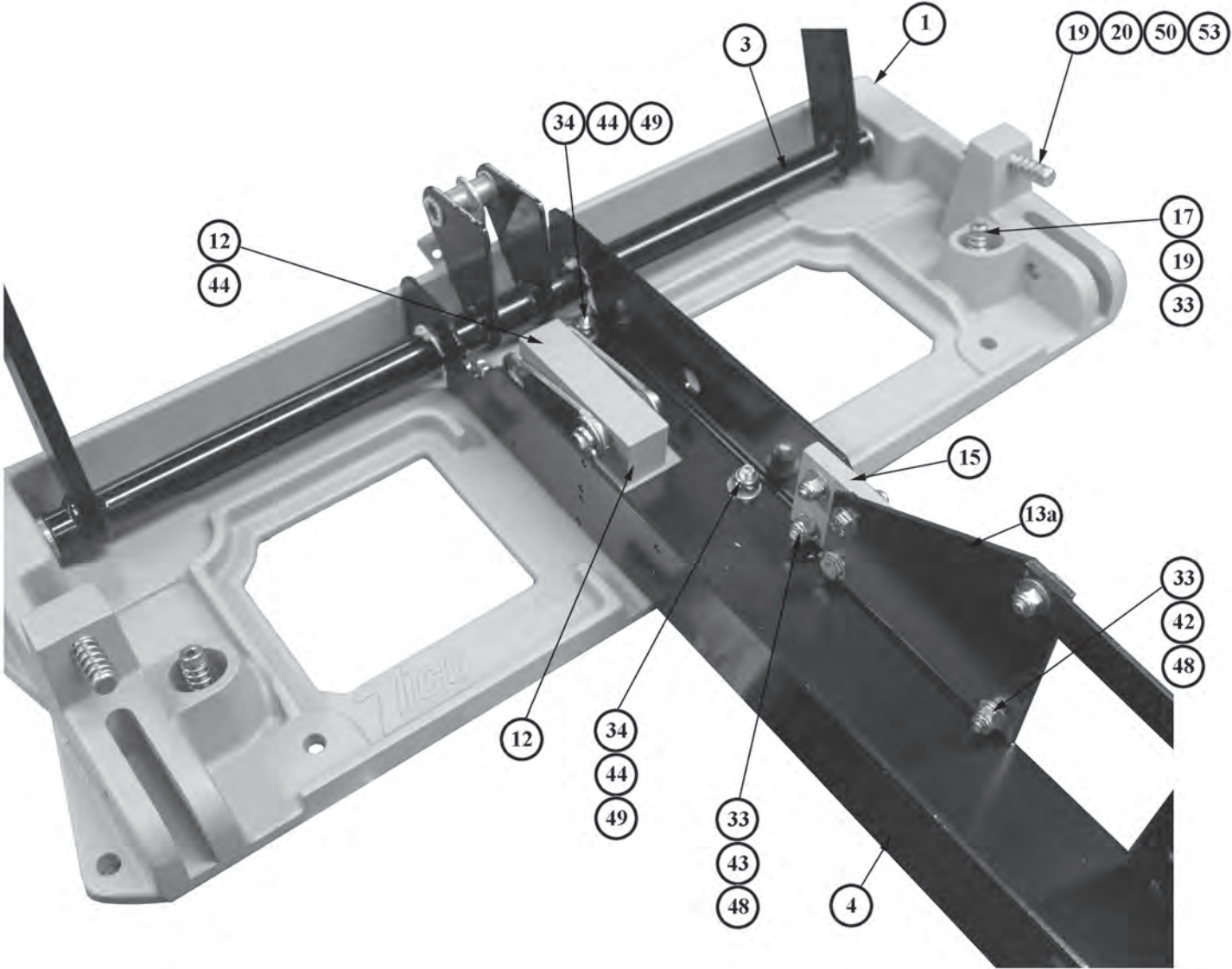

FIGURE 4 - TORQUE TUBE

ITEM	PART NO.	DESCRIPTION	QTY.
1	3094-005-101	BASE CASTING	1
2	3094-030-103	STEP CASTING	1
3	3094-005-105	TORQUE TUBE WELDMENT	1
4	3094-005-133	ACTUATOR ATTACH. BRACKET	1
5	3094-005-113	LINEAR ACTUATOR	1
6	3094-005-115	SHAFT, 1/2ø x 24"	1
7	3094-005-117	SLAVE ARM	2
8	3094-005-119	SHORT LINK	2
9	3094-005-121	LONG LINK	2
10	3094-005-123	KICK PANEL	1
11	3094-005-125	KICK PANEL BRACKET	1
12	3094-005-135	MOUNTING BLOCK, LINKAGE	1
13a	3094-005-137	STIFFENING PLATE A	1
13b	3094-005-138	STIFFENING PLATE B	1
15	3094-005-143	SPACER PLATE	1
17	9110-313116	SHOULDER SCREW, 5/16-18 x 1 S/S	2
18	9010-315032	SHOULDER SCREW, 1/2 - 13 x 2/3/8-16TH.	1
19	3094-005-180	SPRING BUMPER	4
20	9080-003136	CLEVIS PIN, 5/16 x 2-1/4	2
21	9080-005064	CLEVIS PIN, 1/2ø x 4	1
22	9080-003730	CLEVIS PIN, 3/8 x 1-7/8	1
23	0000-061-020	22-20 GA. CAVITY SEAL, PURPLE	2
24	9080-004332	CLEVIS PIN, 7/16 x 2	4
25	3094-005-182	BUSHING SHAFT, .500 ID x 5/8 OD, .1 FL, BRONZE	2
26	3094-005-184	SLEEVE, 3/8 ID x 5/8 OD x 1.625 LG., SS	1
27	3094-005-186	SPACER, .75 OD, .781 LG. x .083 WALL, ALUM. TBG.	1
28	3094-005-188	SPACER, .75 OD x 1.25 LG. x .083 WALL, ALUM. TBG.	1
29	0000-061-018	20-18 GA. CAVITY SEAL, GREEN	2
30	9080-004356	CLEVIS PIN, 7/16 x 3-1/2	2
32	9113-171900	HEX NUT, 10-24, ESNA LOCKNUT S/S	8
33	9113-172500	HEX NUT, 1/4-20, ESNA LOCKNUT S/S	10
34	9113-173100	HEX NUT, 5/16-18, ESNA LOCKNUT S/S	6
35	9018-173700	HEX NUT, 3/8-16, ESNA LOCKNUT GR. 8	1
36	9112-203700	HEX NUT, 3/8-16, JAM S/S	1
37	0000-060-002	WEATHER PACK HOUSING, FEMALE	2
40	0000-060-001	WEATHER PACK HOUSING, MALE	2
41	9110-221912	SCREW, #10-24 x 3/4, PHIL. PAN HD. S/S	8
42	9110-102512	SCREW, 1/4-20 x 3/4, HEX HD. S/S	4
43	9110-102516	SCREW, 1/4-20 x 1, HEX HD. S/S	4
44	9018-363116	SCREW, 5/16-18 x 1, FLAT HD. SOCKET GR. 8	6
45	9018-103740	SCREW, 3/8-16 x 2-1/2, HEX HD. GR. 8	1
46	0000-062-180	20-18 GA. WEATHER PACK TERMINAL, MALE	2
47	9114-101900	WASHER #10 NOM S/S	8
48	9114-112500	WASHER, 1/4ø NOM. S/S	16
49	9114-113100	WASHER, 5/16ø NOM. S/S	6
50	9014-113700	WASHER, 3/8ø NOM.	3
51	9114-114300	WASHER, 7/16ø NOM S/S	6
52	9114-105000	WASHER, 1/2ø NOM S/S	4
53	9170-001212	COTTER PIN, 1/8 x 3/4 S/S	11
54	9110-363112	SCREW, 5/16-18 x 3/4, FLAT HD. SOCKET S/S	2
55	9014-133700	WASHER, 3/8ø NOM. GR. 8	2
56	0000-062-181	20-18 GA. WEATHER PACK TERMINAL, FEMALE	2
58	3094-005-195	INPOWER MODULE	1
60	0000-000-112	SERIAL NUMBER LABEL	1
61	9120-101103	DRIVE SCREW #4 x 3/16 TYPE U	2
62	3094-005-190	WARNING LABEL, ELECTRICAL SHOCK	1

**FIGURE 5 -
ACTUATOR RETAINER BRACKET**



**FIGURE 6 -
LOWER ASSEMBLY**

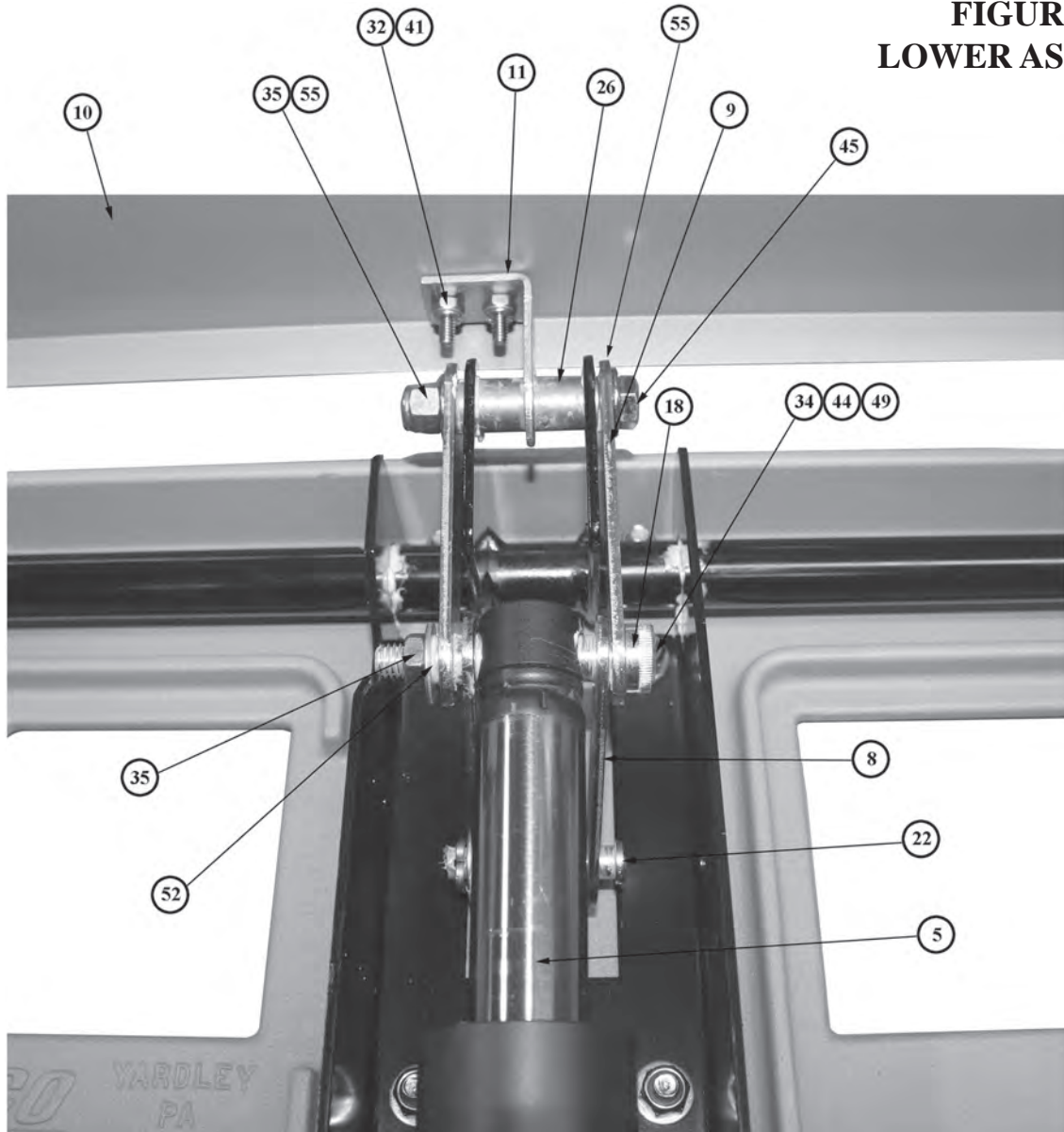
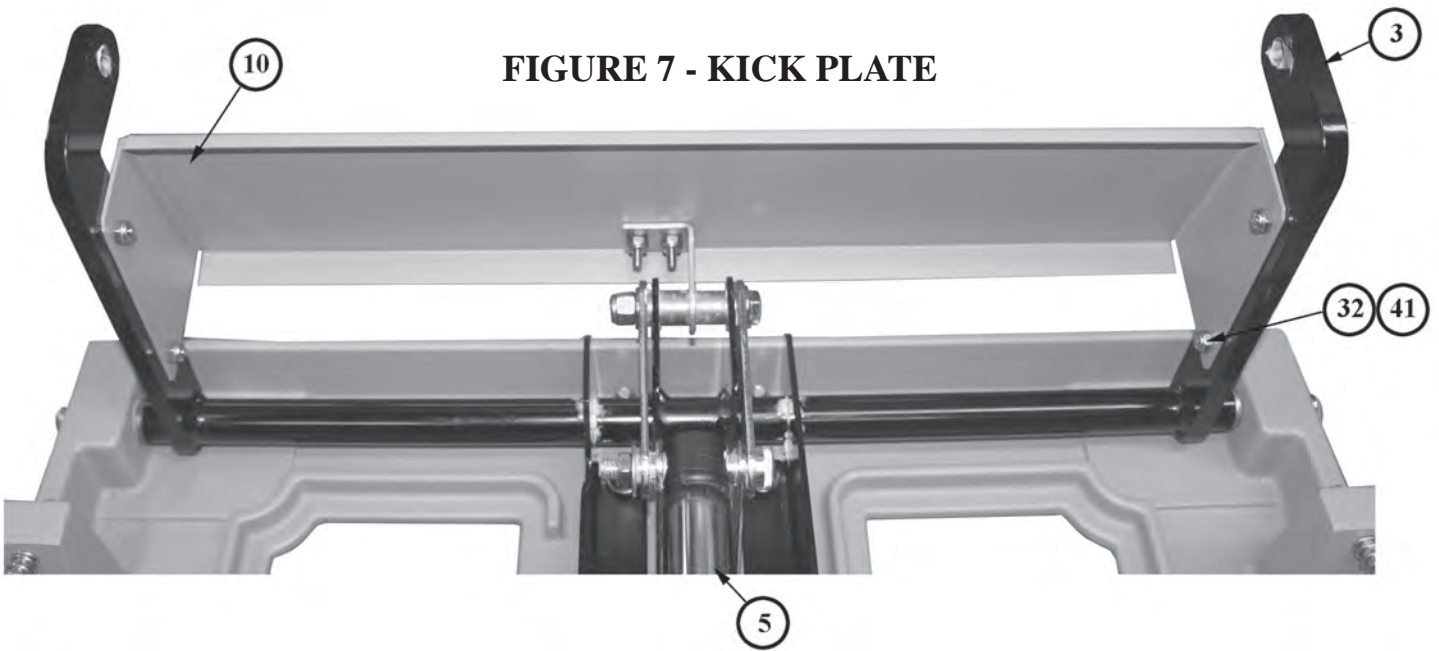
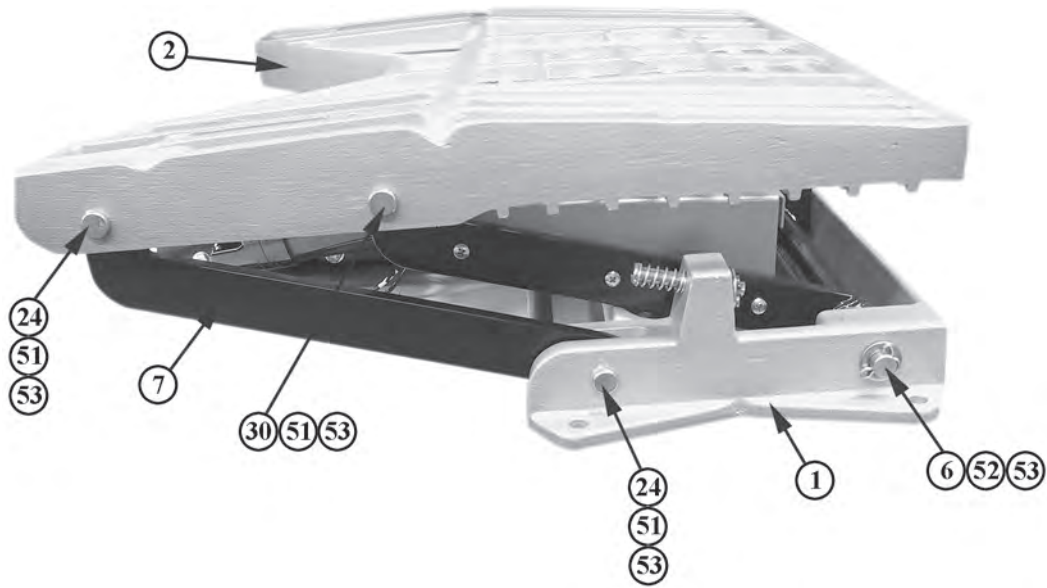

FIGURE 7 - KICK PLATE





**FIGURE 8 -
SIDE VIEW
(upside down)**

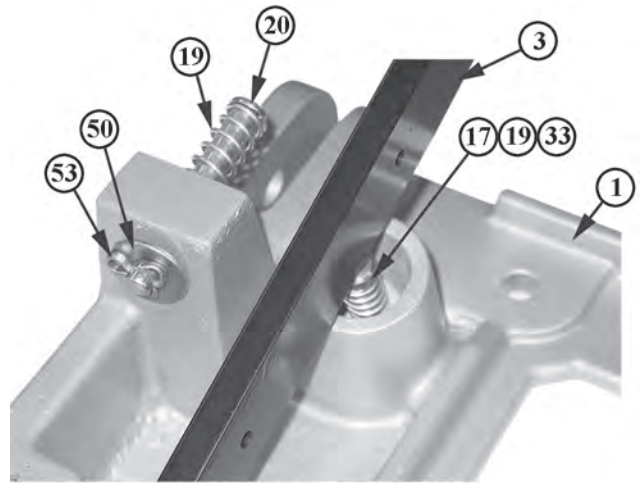
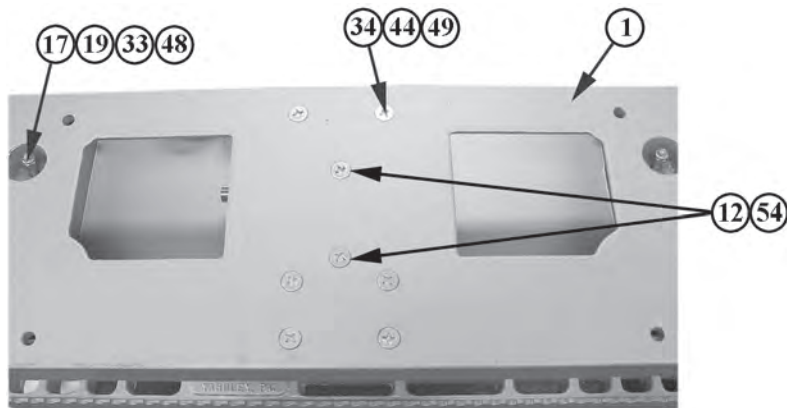

FIGURE 9 - SPRINGS

FIGURE 10 - TOPSIDE OF BASE



SERIAL NUMBER

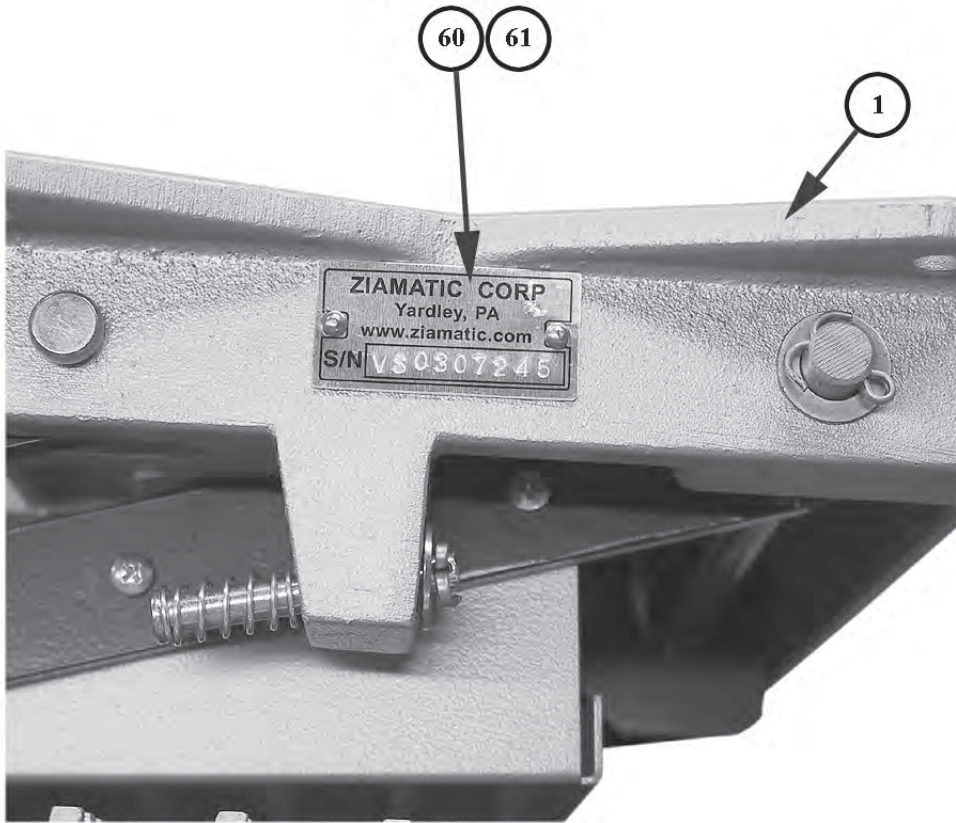

FIGURE 11 - SERIAL NUMBER LABEL

Mounting to Apparatus

- A. A 7-1/16" center to center hole pattern is provided in the side flanges of the base casting. Additional holes may be added as needed.
- B. 3/8" diameter mounting hardware, a minimum of four, is required.
- C. The apparatus structure that the step is mounted to must be strong enough to support 500 lbs. on the extended step.

Maintenance

- A. Semi-Annually or at Scheduled Apparatus Lube Service
 - 1. Visually inspect step for excess dirt build-up and debris.
 - 2. Lubricate all joints and pivots with CRC Stor & Lube long-term lubricant and rust preventative #03032. Excess lubrication should be wiped off.
 - 3. Electric Actuator - We suggest the exposed shaft be cleaned and sprayed with WD40 or a similar light, moisture-repelling silicone type lubricant.
- B. Pressure Washing

Do not operate pressure washer around or near the electric actuators. Excessive pressure may allow soap and water to blow past the seal, damaging the actuator.



Ziamatic Corp.

10 West College Avenue, P.O. Box 337, Yardley, PA 19067-0587 • (215) 493-3618 • FAX: (215) 493-1401

*ZICO is a registered trademark for fire, safety and marine products made by Ziamatic Corp.

www.ziamatic.com
TOLL FREE: 800-711-3473

Copyright Ziamatic Corp. 2-15

WARRANTY REGISTRATION

PLEASE MAIL OR FAX A COPY TO ZICO AT 866-493-1401 TO REGISTER YOUR UNIT

FIRE DEPARTMENT NAME: _____ CONTACT PERSON: _____

PHONE NO. _____ FAX NO. _____

STREET ADDRESS: _____ P.O. BOX: _____

CITY: _____ STATE: _____ ZIP: _____

UNIT MODEL NO.: _____

SERIAL NO. ON UNIT: (SEE PAGE 8 FOR LOCATION) _____

INSTALLED ON: (VEHICLE MFG.) _____ DELIVERED: (DATE) _____

WAS UNIT INSTALLED ON: _____ NEW VEHICLE

_____ RETROFITTED ONTO EXISTING VEHICLE

WHERE DID YOU HEAR ABOUT OUR PRODUCT?

_____ MAGAZINE AD (SPECIFY) _____

_____ DEALER (SPECIFY) _____

_____ VEHICLE MFG. (SPECIFY) _____

_____ ANOTHER DEPARTMENT (SPECIFY) _____

_____ OTHER (SPECIFY) _____