

QUIC-LIFT® OUTSIDE ARM LADDER SYSTEM

MODEL OALS

PARTS AND INSTRUCTION MANUAL

Booklet contains the following sections:

- I. Systems Available
- II. Operating the System
- III. Standard Equipment and general Installation Preparation Guide
 - A. Preparation for Mounting
 - B. Hydraulic Power Unit
 - C. Electrical System
 - D. Switch Panel
 - E. Air Control Valve and Components
 - F. Warning Labels
- IV. Optional Equipment
 - A. Model LAS-LGK Ladder Guard Kit
 - B. Installing the Rung Wear Sleeve
- V. Mounting Instructions
 - A. Base Castings
 - B. Hydraulic System
 - C. Electrical System
 - D. Bleeding the Hydraulic System
 - E. Mounting and Adjusting the Booms
 - F. Mounting the Rack
 - G. Mounting the Boom Stop and Bracket
 - H. Mounting the Power Clamp
 - I. Mounting the Pneumatic System
 - J. Wiring Lights on Booms
 - K. Complete Electrical Wiring
 - L. Mount Ladder Rack Components
 - M. Replace "R" Clips with Cotter Pins
- VI. Trouble Shooting
- VII. Maintenance
 - A. Periodic
 - B. Semi-Annually or At Scheduled Apparatus Lube Service
- VIII. Service
- IX. Warranty

I. Systems Available

Outside Arm Ladder Systems are made to order according to the ladders to be carried. In order to provide the System you require, we need to know the manufacturer, model number, and length of the ladders you plan to carry. The following models are available, depending on the nested depth of the ladder combinations:

MODEL	DESCRIPTION
OALS-775	Outside Arm Ladder System for 7-3/4" Ladder Combination
OALS-975	Outside Arm Ladder System for 9-3/4" Ladder Combination
OALS-1200	Outside Arm Ladder System for 12" Ladder Combination

Systems are also available for customers wishing to make their own ladder racks. These Systems have no rack provided by ZICO:

MODEL	DESCRIPTION
OALS	Basic Outside Arm Ladder System, Less Ladder Rack

Complete rack assemblies may be purchased separately for customers who have their own ladder mounting system. Contact ZICO for more information.

WARNING: The following restrictions apply to all OALS systems:

- **Systems are designed for ladders not exceeding 35' in length**
- **Systems are not designed for ladders with bangers or poles**
- **Maximum weight of ladders and other equipment carried on the ladder rack may not exceed 300 pounds.**

The Outside Arm Ladder System was designed for use with ladders meeting the current NFPA 1931 Standard. Systems will accommodate most ladder combinations, with the exceptions noted above.

OALS SPEC SHEET

This specification sheet will need to be completed prior to acceptance of an order. ZICO will send this sheet to the customer for completion. ZICO Engineering will then confirm that a system is available for your desired ladder combination.

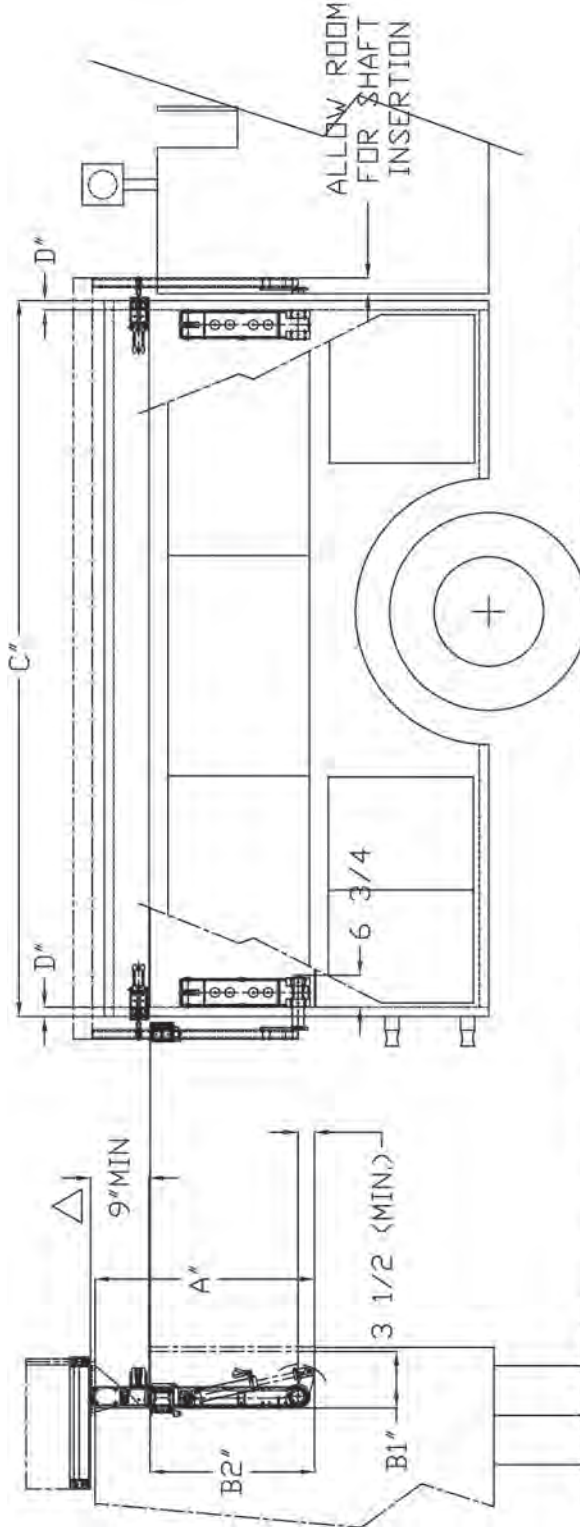

PLEASE PICK APPROPRIATE SHAFT LENGTH
THEN CALCULATE RACK LENGTH

DIM. "D"(RANGE)	SHAFT LENGTH	RACK LENGTH
0.25" - 1"	9.25"	C" + 8.875 - 2D" = _____"
1.06" - 1.5"	9.75"	C" + 9.875 - 2D" = _____"
1.56" - 2"	10.25"	C" + 10.875 - 2D" = _____"
2.06" - 2.5"	10.75"	C" + 11.875 - 2D" = _____"
2.56" - 3"	11.25"	C" + 12.875 - 2D" = _____"
3.06" - 3.5"	11.75"	C" + 13.875 - 2D" = _____"

PLEASE FILL IN INFORMATION BELOW:

SYM	DESCRIPTION	DIM.(INCHES)
A"	SHELF TO TOP OF TRUCK (64" max)	
B1"	SHELF DEPTH(INSIDE) (9 3/8" MIN.)	
B2"	SHELF HEIGHT(INSIDE) (29" MIN.)	
C"	OUTSIDE SKIN DIM.	
D"	OUTSIDE SKIN TO INSIDE MOUNTING FACE (0.25"(MIN))	
EXT. LADDER	MODEL NO.	
ROOF LADDER	MODEL NO.	

* CUSTOMER TO CUT BOOM TO LENGTH REQUIRED TO OBTAIN PROPER TRUCK CLEARANCE
 FROM MOUNTING SURFACE OF POWER CLAMP
 △ TO BOTTOM OF RACK

NOTE: Numbers in parenthesis refer to item numbers. Locate the item number on the enclosed figures (see pages 14 through 42) to find the corresponding parts diagram, parts number and description.

II. Operating the System

The System is designed to operate in the following manner:

1. Turn on the toggle switch on the switch panel assembly (36).
2. Press the "down" switch to unlock the power clamp (23).
3. When the power clamp is fully opened the hydraulic power unit will activate, lowering the rack.
4. Release the toggle switch when the rack is all the way down.

III. Standard Equipment and General Installation Preparation Guide

A. Preparation for Mounting

1. Confirm the body mounting surfaces for the left and right base castings (1) are square with each other and with the center line of the body.
2. Confirm center lines of the main shaft hole and the base mounting bolt patterns are aligned with each other from a common location.
3. The booms (13) are 62" long and machined on the bottom end. Customer will cut booms to desired length to obtain proper clearance.
4. Shaft weldments (2) are available in six predetermined lengths. When installed there should be at least 1-1/2" between the inner face of the booms (13) and the body parts (side panel, drip lip, lights, louvers and doors). Refer to the chart on page 3 to determine which shaft and length of the rack is required.

D. Switch Panel (see page 33)

1. The switch panel assembly (36) should be mounted in a water-proof compartment where it will be readily accessible to the operator, but out of the direct path of the moving components of the System. The operator must have a clear view of the rack when it is in motion.

E. Air Control Valve and Components (see page 37)

1. The air control valve (26) should be located in proximity with the electrical control panel.

F. Warning Labels (see page 42)

1. Warning labels are supplied with each OALS. The pressure sensitive or metal labels must be mounted in close proximity to the switch panel assembly (36). All apparatus operators must be instructed to keep the area in front of the ladders clear of personnel when the System is being raised or lowered.

IV. Optional Equipment

A. Model LAS-LGK Ladder Guard Kit

The Ladder Guard Kit contains one tube of epoxy and two stainless steel guards. The guards may be attached to the ladder rung to prevent wear and possible damage as a result of the locking handle's contact with the rung.



Our new handle assemblies have a replaceable plastic wear pad (R-33) (see page 38), which should prevent damage to the rungs, but the Ladder Guard Kit may also be required if exceptional wear is noted.

B. Installing the Rung Wear Sleeve

Small plastic sleeves may be purchased directly from your ladder manufacturer. The sleeves are pop-riveted to the rungs and prevent unnecessary wear to the rungs caused by constant rubbing against the side rails.

V. Mounting Instructions

A. **Base Castings** (see pages 14 - 19)

Use the following steps in preparing the base casting assemblies for mounting:

1. Remove "R" clips from cylinder pins (65 & 66) on the hydraulic cylinder (4).
2. Set hydraulic cylinders and attached hose lines aside.
3. Remove three 3/8-16 x 1" hex head bolts (46) and 3/8" ID lock washers (59) from the lock plate (9) and set aside.
4. Pull shaft (2) out of main body casting (1) and lay aside, while an assistant holds the crank casting (3), which will become free as the shaft is removed. NOTE: There is a left and right side of shaft.
5. Remove inboard (7) and outboard thrust washers (8) and lay aside.
6. Mount the main casting to the end panel (grade 8 mounting hardware not provided). The shaft and mounting holes may be pre-drilled or punched in advance or they may be drilled at this time.
7. After bases (1) are mounted to body and the shaft weldments (2) **only** are slid through and secured with lock plates (9), then you may mount the booms (13). Check for parallel between booms in the "up" and "down" positions. If the measurements are more than 1/2" out on the booms, shim both bases equally to correct.
8. When alignment is correct, remove the shaft weldments and booms and install shaft seal (83) and seal ring (84).
 - a. If your apparatus is of single wall construction: Use 3/8" mounting bolts to secure the rubber shaft seal (83) and seal ring (84) to the base via the four larger holes in the shaft seal, making sure to keep anti-crush spacers (98) in place (see page 22).
 - b. If your apparatus is of double wall construction: The rubber shaft seal (83) and seal ring (84) can be mounted, via the four smaller holes in the shaft seal, to the apparatus' outer layer using 1/4" hardware (see page 22).
9. Re-assemble the base components in the following order (see pages 17 - 19):
 - a. Attach outboard thrust washer (8) to outboard bearing (5) between the two ears of the base castings with a coating of grease (universal chassis lubrication).
 - b. Attach the inboard thrust washer (7) to inboard bearing (6) also between the two ears of the base casting with a coating of grease.

- c. Use provided Styrofoam piece or, if discarded, you may use rubber 1/2" thick x 1-7/8" high x 2-3/8" long.
- d. Place keys (10) in the slots of the crank casting (3) with a liberal coating of grease.
- e. Slide the piece of Styrofoam between the two keys.
- f. Hold the crank casting, with the Styrofoam, between the two ears on the base casting.
- g. An assistant may now slowly slide the shaft weldment (2a or 2b) depending upon the side) into the base casting.
- h. When the slots in the shaft weldment (2) are properly aligned with the keys (10) in the crank casting (3) the Styrofoam piece will slide out of the open hole.
- i. Slide the lock plate (9) over the slot in the end of the shaft weldment (2) and align holes.
- j. Secure lock plate (9) to base casting (1) using the hardware provided.

B. Hydraulic System (see pages 20 & 21 and pages 25 - 27)

1. Re-insert the hydraulic cylinders (4) and secure in place with cylinder pins (65 & 66) and "R" clips.
2. Install hydraulic power unit (17) with mounting bracket (15) in location previously determined.
3. Reference Hydraulic Circuit (see page 21):
 - a. Connect hoses (42) from the blind side of each cylinder at elbow (41) to the first tee (38).
 - b. Connect hoses (42) from the rod side of each cylinder at adapter (40) to the second tee (38).
 - c. connect hose (82) from pump "UP" port to tee from blind side of cylinders.
 - d. Connect second hose (82) from pump "DN" port to tee from rod side of cylinders.

C. Electrical System (see pages 27 - 33)

1. Hookup the permanent electrical system at this time. Mount electrical panel assembly (28) (see pages 28 & 29) and switch panel assembly (36) (see page 33) and run all power lines.

NOTE: At this point "temporary jumpers" on the electrical panel will be required to make the power unit operable in order to adjust booms prior to mounting the boom stop components and power clamp (23) components. Place one jumper between terminals 9 & 10 and another between terminals 2 & 12.

D. Bleeding the Hydraulic System

This procedure is done before the booms are mounted onto the shafts. At this point all hydraulic lines are connected, the hydraulic reservoir is full and the power unit is operational.

During the entire bleeding process the hydraulic fluid in the reservoir should not be allowed to go below the minimum level.

The cylinders may be bled individually or at the same time.

1. To Bleed:
 - a. On one cylinder, loosen the upper hose connection (dead end) a quarter turn.
 - b. At the control panel, press and hold switch in the down position. Observe air and foamy fluid coming out of the loosened fitting.
 - c. Once a solid stream of fluid is observed, stop operation and tighten hose fitting. Repeat procedure on the second cylinder.
 - d. Run System in the "DOWN" mode until both cylinders are fully extended.
 - e. Check that the fluid is above "minimum" but do not fill reservoir to "maximum" level at this time.
 - f. On one cylinder loosen the lower hose connection (rod end) a quarter turn.
 - g. Run System in the "UP" mode and bleed the line as previously described.
 - h. Repeat process on second cylinder.
 - i. Run System until both cylinders are fully retracted.
 - j. Allow 4 to 5 minutes for the hydraulic fluid in the reservoir to settle and then fill the reservoir to "maximum" level.
 - k. Run the System through complete cycle several times allowing 4 to 5 minutes rest in between.
 - l. When power unit operation (sound) is uniform and shaft rotation is smooth, the system is free of air.
 - m. Make sure all connections are re-tightened and check entire system for leaks.

E. Mounting and Adjusting the Booms (see pages 22 - 24)

1. Attach booms to shaft weldments (2) (see page 22). Hand tighten at this time.
2. Run cable (72) through hole for clearance light (70) and out the bottom of the boom.
3. Attach straight connector (43) to end of boom wall spacer (12) and run the free end of the cable through the straight connector. Tighten the straight connector down on the cable until it is held firmly.
4. Insert the boom wall spacer (12) into the bottom end of the boom (13) and tighten mounting hardware (47, 64 & 89). Make sure a few inches of the cable (72) protrude from the hole for attachment of the clearance light (70).
5. Operate the switch panel assembly (36) to raise the booms (13) to the full upright position.
6. Check that booms are vertical, parallel to hose bed wall and in line with each other, while applying outward pressure to eliminate "free-play" accordingly. To adjust:
 - a. Loosen socket head cap screw on clevis end of the hydraulic cylinder (4).
 - b. Lower the booms completely so the shaft on the hydraulic cylinders are fully extended.
 - c. Support boom and remove cylinder pin (66).
 - d. Turn clevis counterclockwise to move the boom away from the body.
 - e. Turn clevis clockwise to move the boom towards the body.
 - f. Turn the clevis in 1/2 turn increments, retighten clamp bolts, and spin clevis and rod together, then reinsert the cylinder pin (66) and "R" clip (68) and run the booms back up to check alignment. If 1/2 turn is too much you can use 1/4 turn increments.

WARNING: Do not use pipe wrench or vise grips. Damage to the cylinder shaft will occur. You may have to put a rod through the holes of the clevis in order to turn it.

- g. When the vertical alignment is complete tighten the clevis clamp screw.

F. Mounting the Ladder Rack (Item numbers with "R" designation refer to Ladder Rack Parts Breakdown, see pages 38 - 41)

1. Mount the rack mounting blocks (R-7) into the four corners of the rack (R-1) using hardware noted on page 38. Measure the total outside distance of the rack, over the mounting blocks.
2. Attach boom end gusset (11) with one shim (29) mounted on either side of the boom.
3. Attach adapter angle (R-12) to gusset (11). Snug fasteners and measure distance between the inside of right hand adapter angle (R-11) and left hand adapter angle (R-12). The distance between the two angles should be equal to the total length of the rack with the rack mounting blocks in place. Move shims (29) until the distances are equal within 1/4".
4. Mount rack (R-1) onto adapter angles (R-11 & R-12) and fasten in place. Tighten all fasteners; gusset to boom, adapter angle to gusset and rack to adapter angle.
5. Apply power to pump and raise booms to full upright position. Apply outward pressure on the rack, to make sure there is no "free-play" and the booms are vertical and parallel to hose bed wall.

G. Mounting the Boom Stop Bracket (see page 23)

1. Mount boom stop bracket (14) and components as follows:
 - a. Mount on the outside panel as close to the top of the compartment as possible.
 - b. The boom adjustable side stop (22) will be on the inside of the boom and the boom and boom wear sleeve (16) will rest in the adjustable saddle (56).
 - c. Place the boom stop bracket assembly on the back side of the boom.
 - d. Raise the boom to the full upright, vertical position.
 - e. Boom needs to be parallel to the back wall. If not, apply outward pressure to rack to make the boom parallel to the back wall and mark outline of the boom stop bracket (14).
 - f. Lower the booms (13) and mount the boom stop bracket to the side panel (mounting hardware not provided).
 - g. Make sure the booms (13) and boom wear sleeves (16) rest firmly against the rubber bumpers (21) in the full-up, stored position and there is no "play" in the system.

H. Mounting the Power Clamp (see pages 35 & 36)

1. Mount power clamp so the spindle (78) is mounted all the way out on the power clamp (23) arm and is centered on the boom (13).

I. Mounting the Pneumatic System

1. Refer to suggested layout on page 37.

J. Wiring Lights on Booms

1. Refer to schematic and photo of materials provided on pages 31 & 34.

K. Complete Electrical Wiring (see pages 27 - 34)

1. Complete all wiring and remove temporary "jumpers" from the electric panel. Secure all wiring.

L. Mount Ladder Rack Components

1. Follow photos on pages 38 - 41 to assemble all components.

M. Replace "R" Clips with Cotter Pins (see page 17)

1. Replace "R" clips with cotter pins (68) on cylinder pins (65 and 66).

VI. Troubleshooting

In the event of a malfunction, contact Zico at 1-800-711-FIRE.

VII. Maintenance

A. Periodic

1. Visually inspect hydraulic system for leaks indicated by the presence of hydraulic fluid or the accumulation of dirt around a fitting.
2. Visually inspect the plastic pads (R-33) on the ladder retainer handle (R-21) for wear and replace as needed.
3. Visually inspect the boom wear sleeves (16) and adjustable side stop (22) for wear. Adjust or replace as needed.

B. Semi-Annually or At Scheduled Apparatus Lube Service

The items listed previously under Periodic Maintenance should be checked first and then proceed to lubricate the following parts as indicated:

1. Joints and pivot points should be sprayed with CRC brand Stor&Lub long term lubricant and rust preventative # 03032. Wipe off excess lubrication.
2. Hydraulic ram is self-lubricating and should require no additional lubrication. We suggest the exposed shaft be cleaned and sprayed with WD-40 or a similar light, moisture-repelling silicone-type lubricant.
3. Grease fittings are located on the ears at the bottom of the base casting (1) and are identified (69) and one grease fitting is located in the end of cylinder pin (66).
4. Check fluid level in hydraulic power unit (17) by visual inspection to see the plastic tank is full, when the rack is in the "up" position. Replenish as required using:
 - **Multi-viscosity hydraulic oil, SAE 5W-20**
 - **System capacity (dry) is approximately one-half gallon**

C. Pressure Washing

Do not operate pressure washer on or anywhere around the hydraulic cylinders. Excessive pressure may allow soap and water to blow past the seal, damaging the cylinders.

VIII. Service

If you experience any problems with your Outside Arm Ladder System, please call ZICO toll free at 800-711-3473 for assistance. Please have the serial number of your system available. This number may be found on the inboard side of the base casting just above the lock plate (9).

IX. Warranty

A copy of the warranty registration **MUST** be returned to ZICO to ensure registration of your System (see back cover).

PART DIAGRAMS

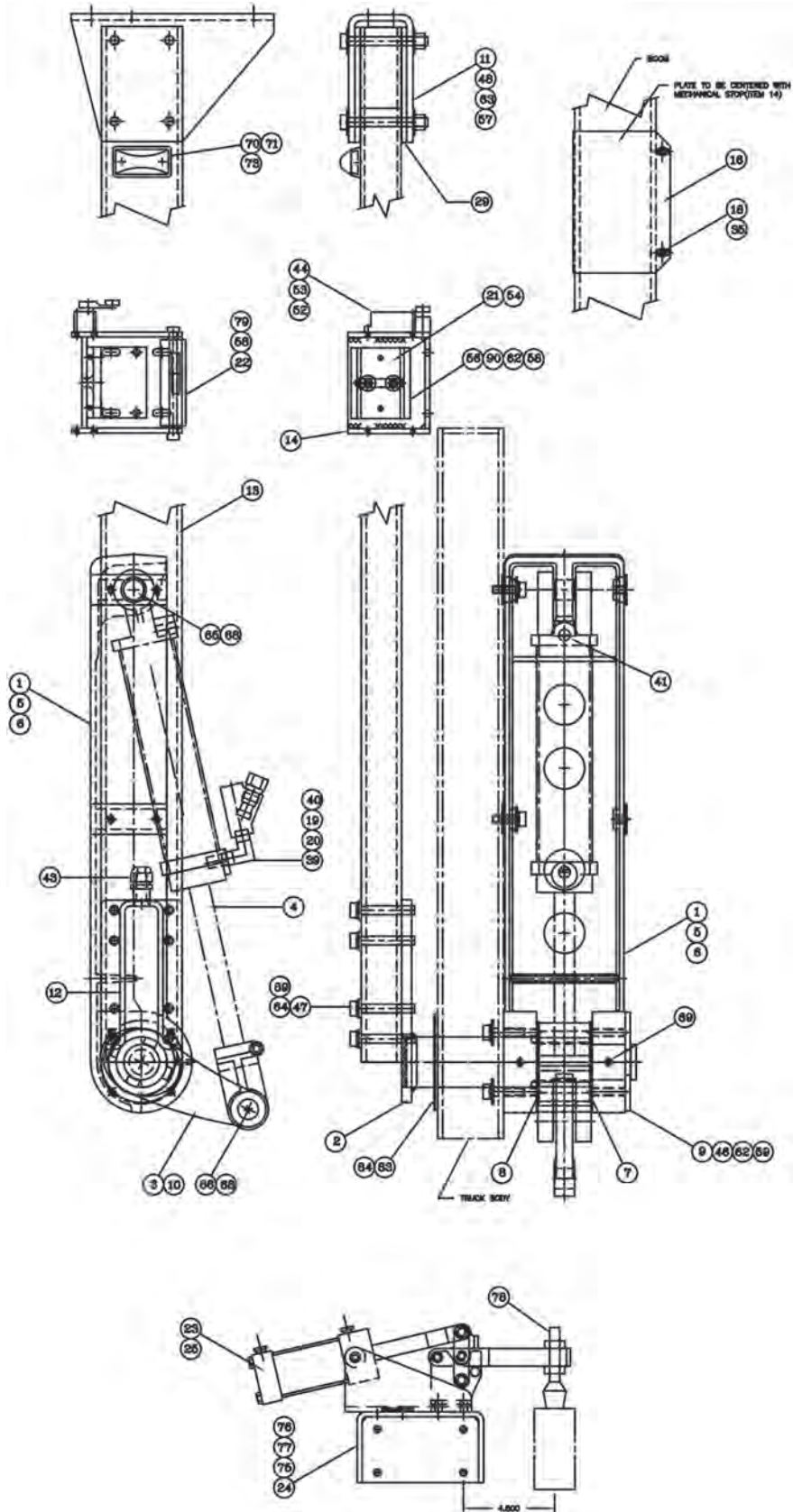

PART BREAKDOWN

ITEM NO.	PART NO.	DESCRIPTION	QTY.
1	3092-005-101	MAIN BASE	2
2A	3092-005-103	SHAFT WELDMENT, LH	1
2B	3092-005-104	SHAFT WELDMENT, RH	1
3	3092-005-105	CRANK	2
4	3092-005-107	HYDRAULIC CYLINDER	2
5	3092-005-109	OUTBOARD BEARING	2
6	3092-005-111	INBOARD BEARING	2
7	3092-005-113	INBOARD THRUST WASHER	2
8	3092-005-115	OUTBOARD THRUST WASHER	2
9	3092-005-117	LOCK PLATE	2
10	3092-005-119	KEY, 5/8 SQUARE 2.5" LONG, TOL. +000/-0.002, TO BE ZP	4
11	3092-005-121	GUSSET, BOOM END	2
12	3092-005-122	SPACER, BOOM WALL, SHAFT END	2
13	3092-005-123	BOOM, 2 x 4 x 1/4 ALUM.	2
14	3092-005-124	STOP BRACKET, BOOM	2
15	3092-005-125	MOUNTING BRACKET, POWER UNIT	1
16	3092-005-126	WEAR PLATE, BOOM	2
17	3092-005-127	HYDRAULIC POWER UNIT	1
18	3092-005-128	TRUNNION NUT	4
19	3092-005-129	RESTRICTOR FIXED ORIFICE	2
20	3092-005-131	BODY, CARTRIDGE	2
21	3092-005-130	RUBBER BUMPER	2
22	3092-005-132	ADJUSTABLE SIDE STOP, BOOM	2
23	3092-005-133	PNEUMATIC POWER CLAMP W/MAG. RING	2
24	3092-005-134	MOUNTING BRACKET, POWER CLAMP	2
25	3092-005-135	LIMIT SWITCH, SPST, N.O. LSIA, LSIB	2
26	3092-005-137	DIR. CTRL. VLV, DBL. SOL.	1
27	3092-005-139	POWER CONTACTOR	2
28	3092-005-148	ELECTRICAL PANEL ASSY.	1
29	3092-005-149	SPACER, ALUM. 1/4 THK	4
30	3092-005-151	ELBOW, 1/8 MNPT x 1/4 OD COMP.	4
31	3092-005-152	TEE, 1/4 OD COMP	2
32	3092-005-153	ADAPTER, 1/8 MNPT x 1/4 OD COMP	3
33	3092-005-154	AIR MUFFLER	2
34	3092-005-157	TUBING, 1/4 OD x 1/8 ID POLYETHYLENE	40'
35	9110-382310	SETSCREW, 1/4-28 x 5/8, CUP POINT, SS	4
36	3092-005-179	SWITCH PANEL ASSY W/WIRING HARNESS	1
37	3092-005-161	ADAPTER, SAE4 (7/16-20 UNF) x 37° FL	2
38	3092-005-163	TEE, 7/16-20- 37° FL	2
39	3092-005-165	ELBOW, 3/8 NPT MALE	2
40	3092-005-167	ADAPTER, 3/8 NPT MALE x 1/4 37° FL	2
41	3092-005-169	ELBOW, 3/8 NPT MALE x 1/4 37° FL	2
42	3092-005-171	HYDRAULIC LINE ASSY. 18 FT.	4
43	3097-500-172	STRAIGHT CONNECTOR, PLASTIC, 1/2 NPT	4
44	3097-500-181	LIMIT SWITCH LS3A, LS3B	2
45	9010-103712	SCREW, 3/8-16 x 3/4, HEX HD. (PUMP)	2
46	9010-103716	SCREW, 3/8-16 x 1, HEX HD. (LOCKPLATE)	6
47	9018-114448	SCREW, 7/16-20 x 3, HEX HD. GR. 8 (BOOM TO SHAFT)	16
48	9018-114464	SCREW, 7/16-20 x 4, HEX HD GR. 8 (BOOM TO GUSSET)	8

PART BREAKDOWN

ITEM NO.	PART NO.	DESCRIPTION	QTY.
49	9018-114422	SCREW, 7/16-20 x 1-3/8, HEX HD, GR. 8 (GUSSET TO ANGLE)	4
50	9018-165022	SCREW, 1/2-20 x 1-3/8, FH, GR. 8 (GUSSET TO ANGLE)	4
51	9010-102510	SCREW, 1/4-20 x 5/8 HEX. HD, (SOLENOID)	4
52	9110-162008	SCREW, 10-32 x 1/2 PH, SS (BOOM UP SWITCH) (GRND BAR)	10
53	9014-201900	LOCKWASHER, #10, SPLIT	8
54	9010-162010	SCREW, 10-32 x 5/8 FH, ZPZ (RUBBER BUMPER)	4
55	9013-172500	NUT, 1/4-20 HEX, NYLON INSERT LOCKNUT	4
56	3092-005-136	ADJUSTABLE SADDLE	2
57	9013-254300	NUT, 7/16-20 HEX, NYLON INSERT LOCKNUT	16
58	9113-173700	NUT, 3/8-16 HEX, NYLON INSERT LOCKNUT, SS	2
59	9014-203700	LOCKWASHER, 3/8 ID SZP	8
60	9014-11900	FLATWASHER, #10, SZP	2
61	9014-112500	FLATWASHER, 1/4 ID, SZP	12
62	9014-113700	FLATWASHER, 3/8 ID, SZP	8
63	9014-114300	FLATWASHER, 7/16 ID SZP	16
64	9014-184300	FLATWASHER, 7/16 ID x 59/64 OD x .125 THK. (FOR GR. 8)	32
65	3097-500-226	CYLINDER PIN, UPPER (PROVIDED W/CYLINDER)	2
66	3097-500-126	CYLINDER PIN, LOWER (W/GREASE FITTING)	2
67	3092-005-181	TERM. BLOCK W/BUS BAR 4 x #10	1
68	9070-001524	COTTER PIN, 5/32 ϕ x 1-1/2	4
69	3097-500-162	SPIN DRIVE GREASE FITTING, 1/4-28	6
70	3097-270-102	CLEARANCE LIGHT	2
71	000-015-101	SNAP PLUG CONN	4
72	3097-510-110	CABLE, 2 COND., 16 GA. JACKETED	100'
73	9025-221108	SCREW, #4-40 x 1/2 SELF TAP RND HD SZP	4
74	9013-172000	NUT, 10-32 HEX, NYLON INSERT LOCKNUT	2
75	9010-103116	SCREW, 5/16-18 x 1" HEX. HD. (POWER CLAMP)	8
76	9113-173100	NUT, 5/16-18 HEX, NYLON INSERT LOCKNUT, SS (POWER CLAMP)	8
77	9014-113100	FLATWASHER, 5/16 NOM. ID (POWER CLAMP)	8
78	3092-005-178	SPINDLE W/CAP, (POWER CLAMP)	2
79	9010-103788	SCREW, 3/8-16 x 5.5 LG. GR. 8	2
80	3092-005-140	LABEL, WARNING "HANDS & ARMS MAY..."	1
81	3092-005-159	SUB-PANEL, ALUMINUM	1
82	3097-500-132	HYDRAULIC LINE ASSY., 37 $^{\circ}$ FEM SWIVEL	2
83	3092-005-138	SHAFT SEAL	2
84	3092-005-120	SEAL RING	2
85	3097-500-178	SWITCH PLATE, ALUMINUM	1
86	3097-500-179	NAME PLATE	1
87	3092-005-187	HOSE CPLG., SOCKET, 1/4 CPLG, 1/4 NPTF (MALE), HI-PRESS	4
88	3092-005-188	HOSE CPLG., SOCKET, 1/4 CPLG. 1/4 NPTF (FEMALE), HI-PRESS	4
89	9014-214300	LOCKWASHER, 7/16 SPLIT, GR. 8	16
90	9010-363720	3/8-16 x 1-1/4 FH CAP SCREW, ALLEN	4
91	9018-175000	1/2-20 HH NYLON INSERT LOCKNUT GR. 8	4
92	9014-185000	FLATWASHER, 1/2 ID NOM., GR. 8	4
93	3097-500-423	LABEL, "LOSS OF HYDRAU..."	1
94	3097-500-427	LABEL, "KEEP CLEAR..."	1
95	3092-005-182	JUG, 1 GAL. HD POLYETHYLENE 6 ϕ x 12 HT.	1
96	3092-005-189	SPACER, MECHANICAL STOP BRACKET	AR
97	3092-005-190	CLAMP, BAND, FOR LIMIT SWITCH	2
98	9114-103700	SPACER, SHOULDER BOLT	8

BASE COMPONENTS - RIGHT SIDE

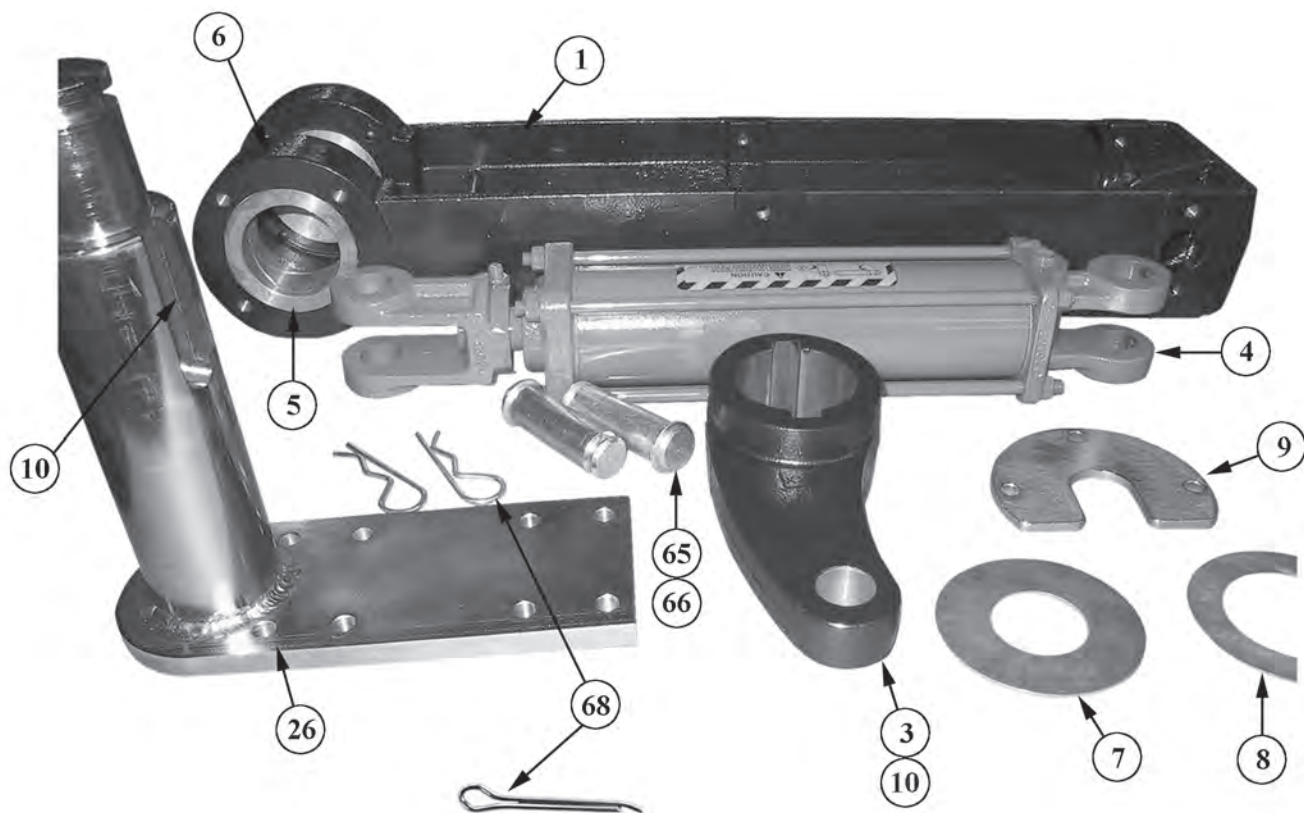

***NOTE: "R" clips are replaced with cotter pins (68) in final assembly.**

BASE ASSEMBLY - RIGHT SIDE

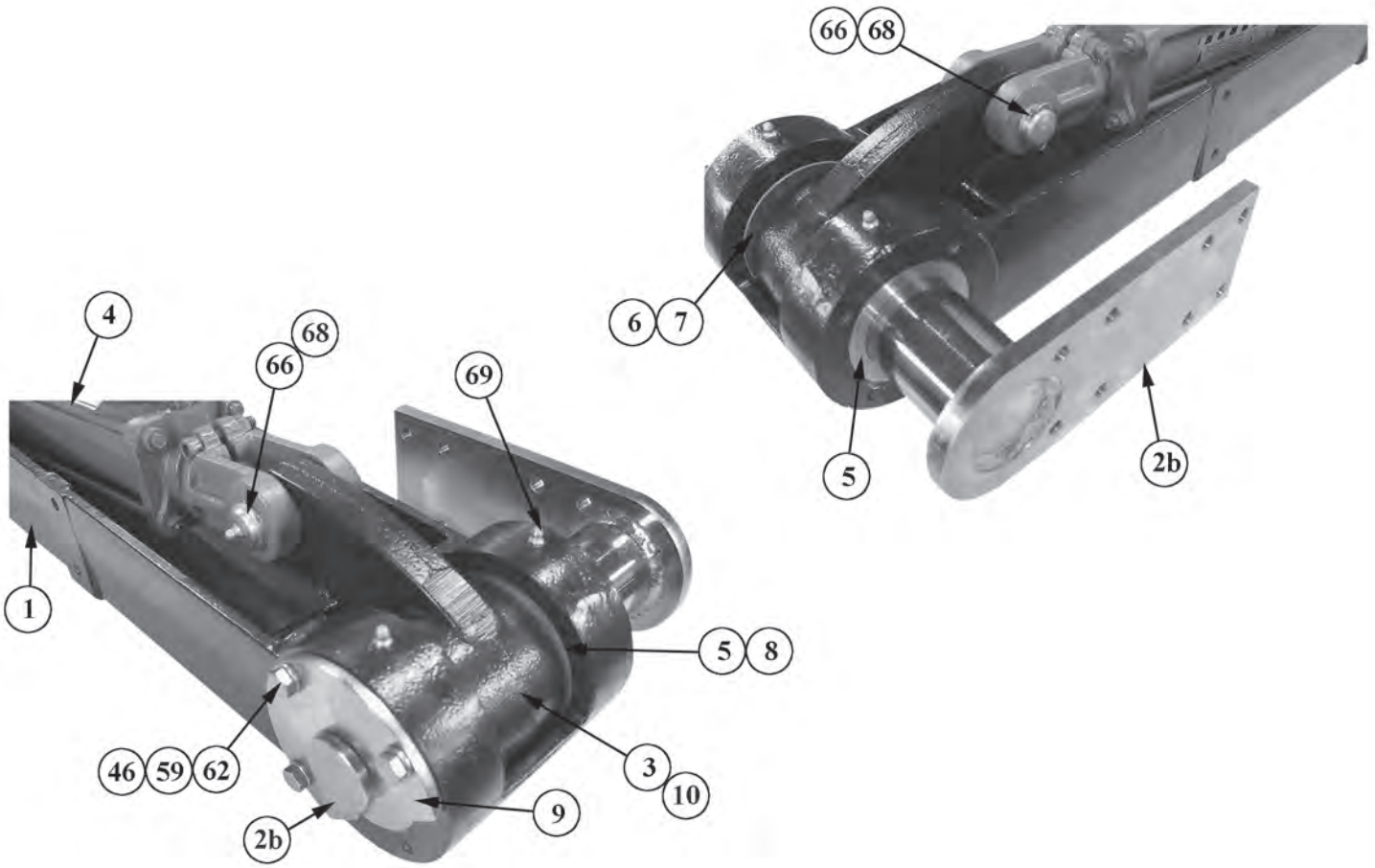

RE-ASSEMBLY OF BASE COMPONENTS



1. Slide Styrofoam between the two keys.



2. Base casting ears showing hole for shaft insertion.

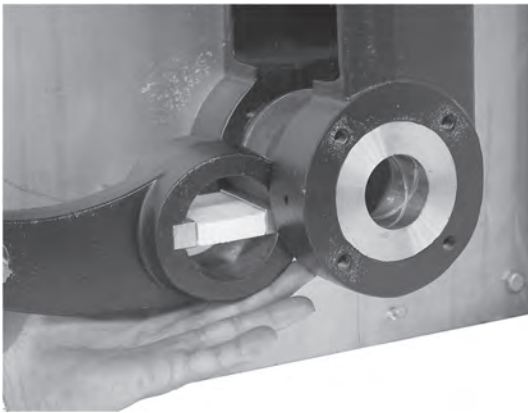

3. Move the crank casting into position.

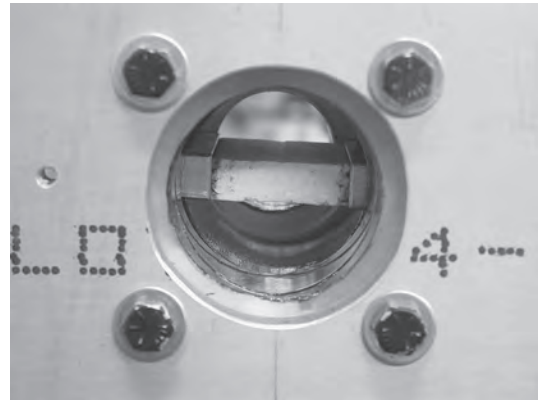

4. Shaft end view showing Styrofoam between keys.

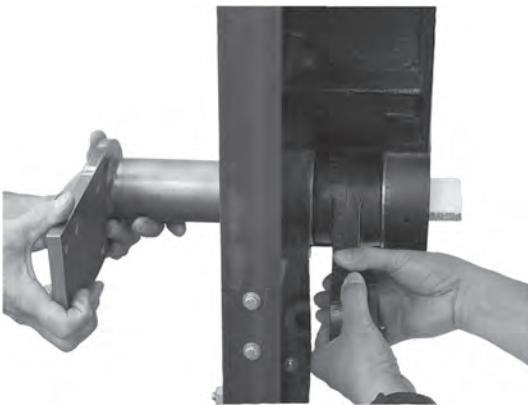

5. Styrofoam coming out as shaft is inserted.



6. Slide lock plate in position and insert fasteners.

HYDRAULIC CYLINDER AND COMPONENTS

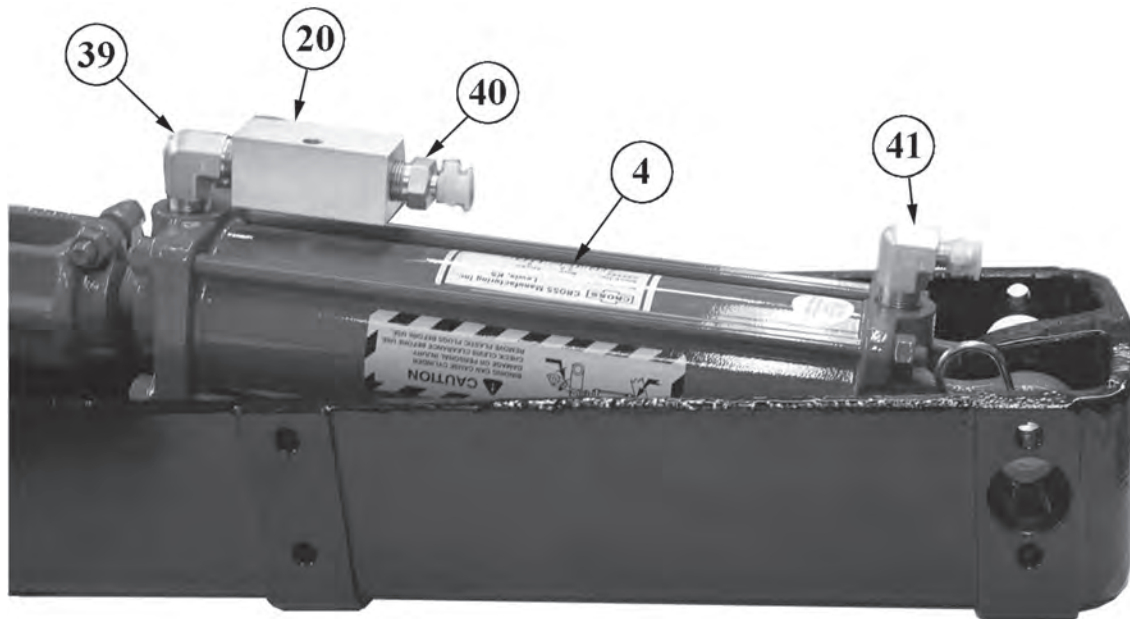

NOTE: Two hydraulic line assemblies (42) attach to Adapter (40) and Elbow (41).

NOTE 2: Elbows are factory set and should not be turned.

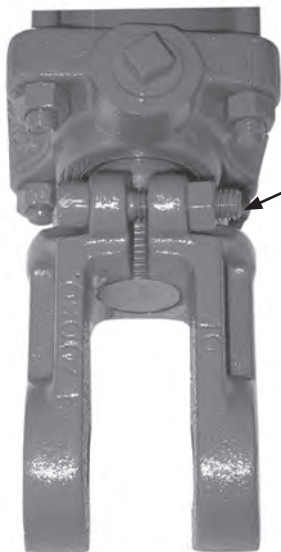

Socket head cap screw on clevis (see Adjusting the Booms, page 10).

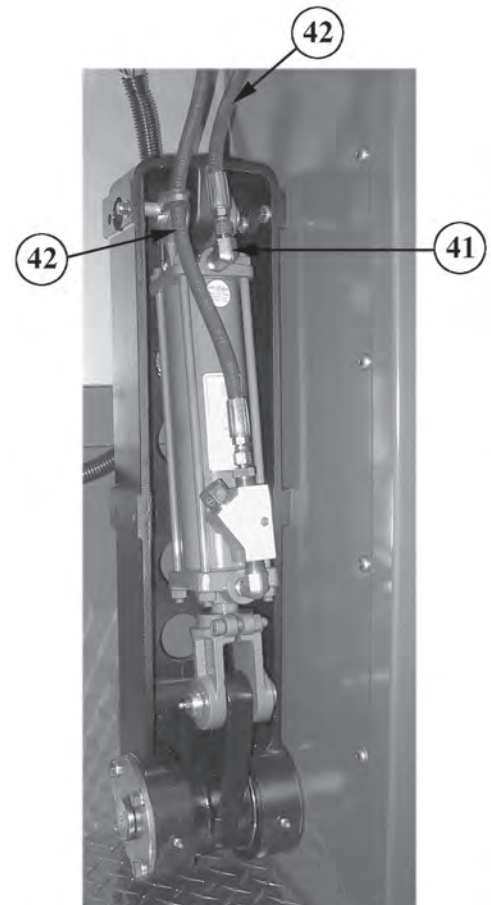

BOOM ATTACHMENT TO SHAFT WELDMENT

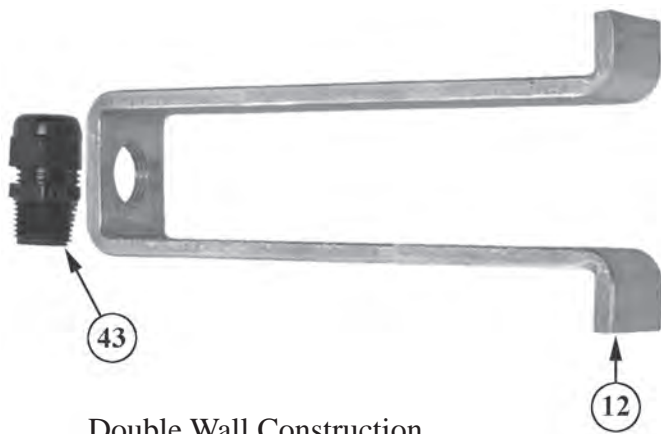
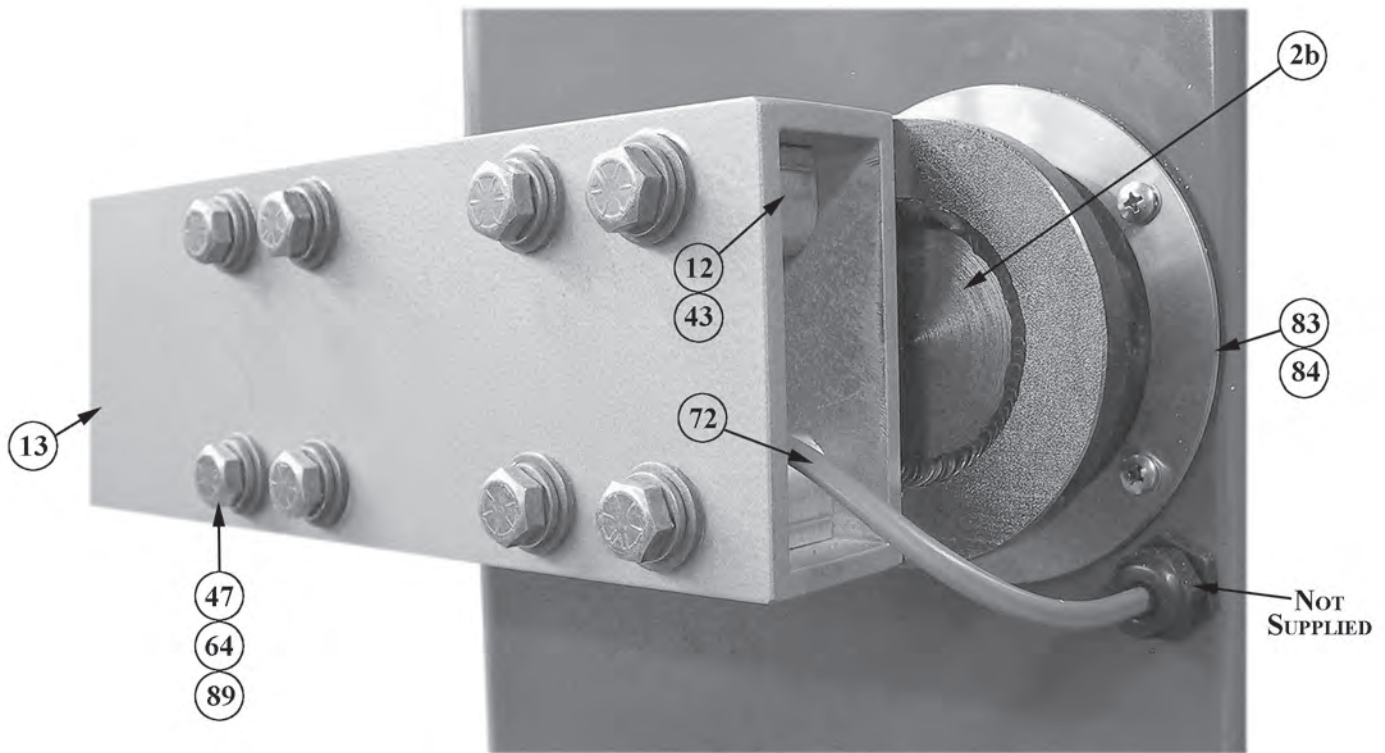

Double Wall Construction

NOTE: Spacer (12) is located inside of the boom with the Straight Connector (43) connected to top in order to guide Cable (72) down through the center of the boom.

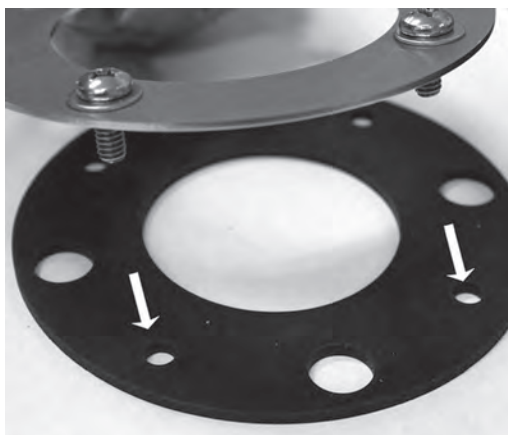

Single Wall Construction

BOOM STOP BRACKET COMPONENTS & ASSEMBLY

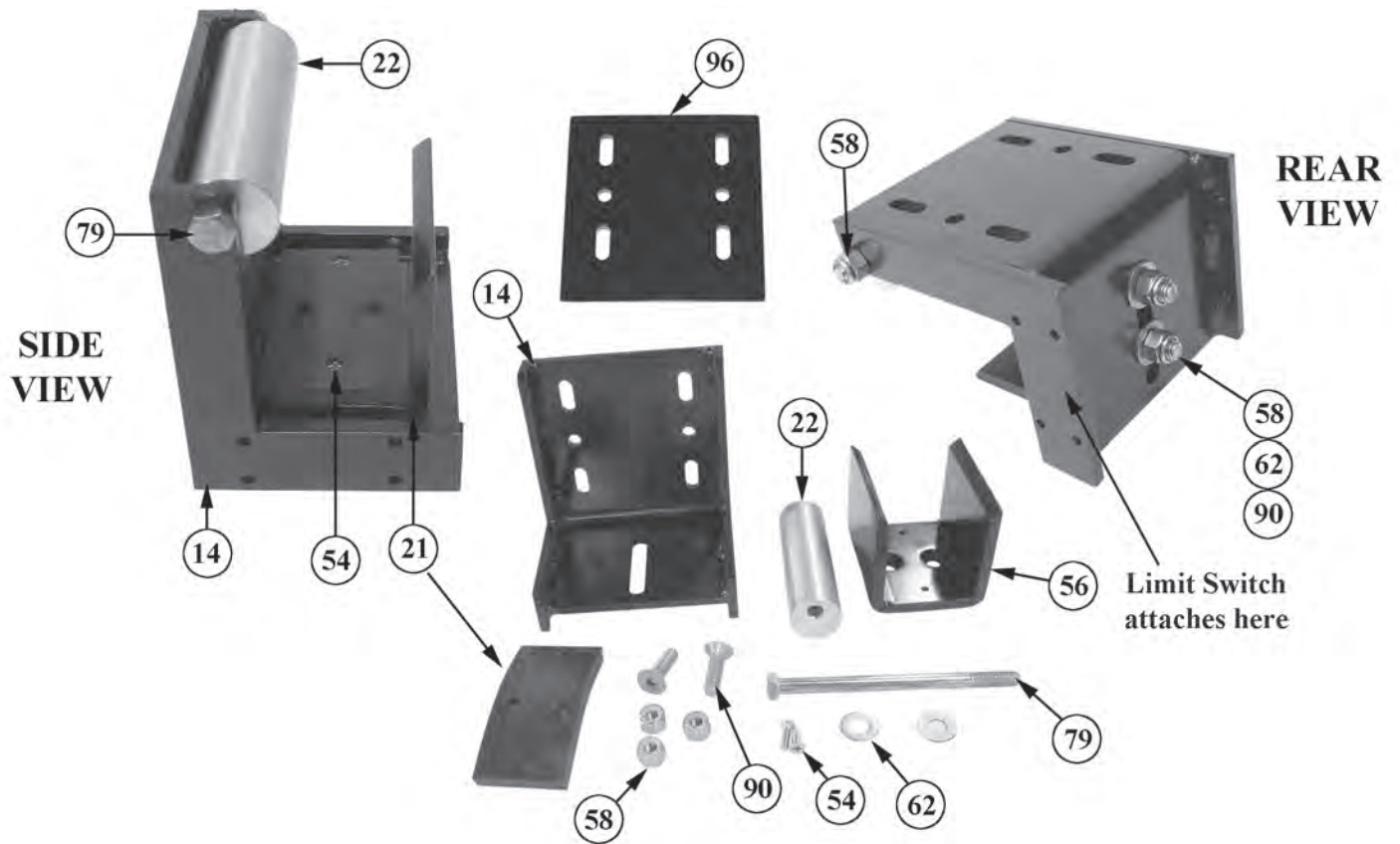

Boom wear sleeve (16) attaches around boom and will come into contact with adjustable side stop (22) and rubber bumper (21). Adjustable side stop (22) may be rotated in or out to achieve proper contact.



TOP END OF BOOM

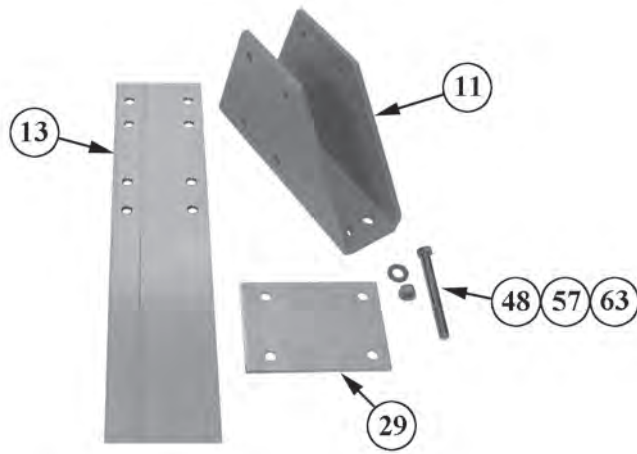
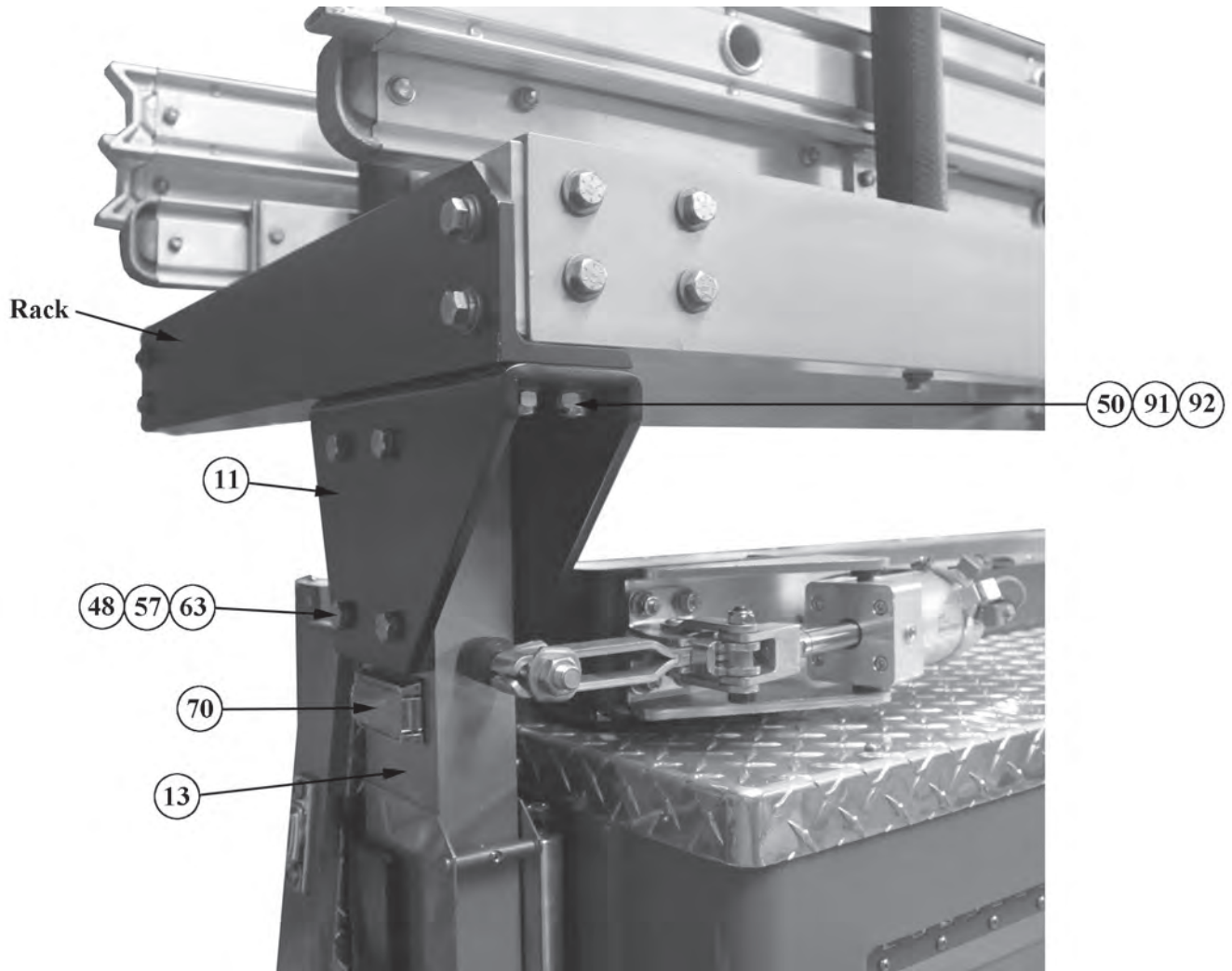

HYDRAULIC POWER UNIT ASSEMBLY

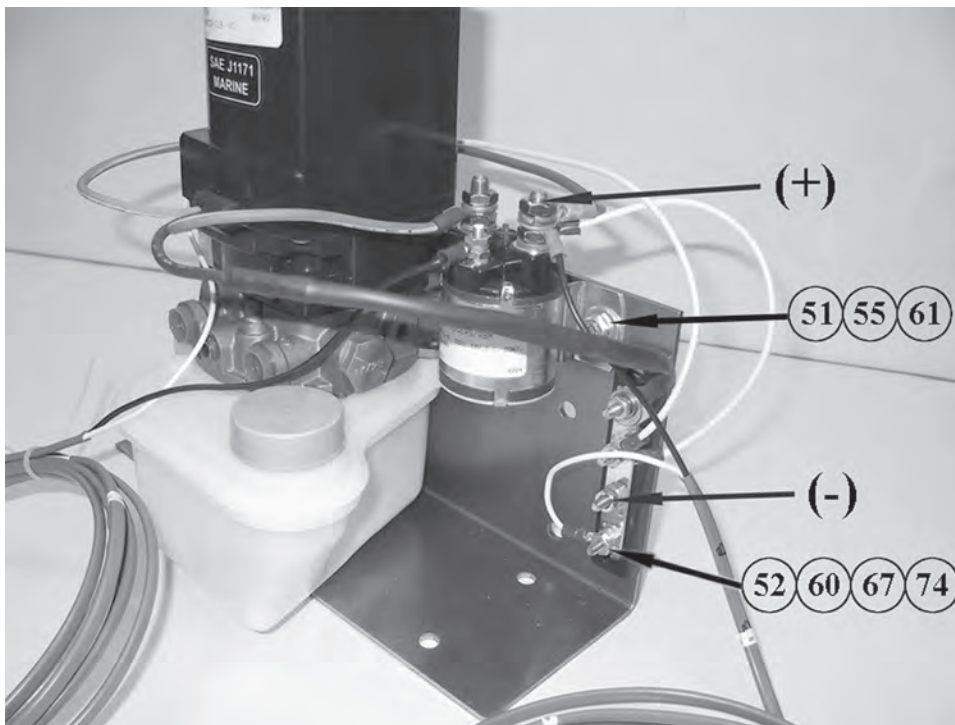
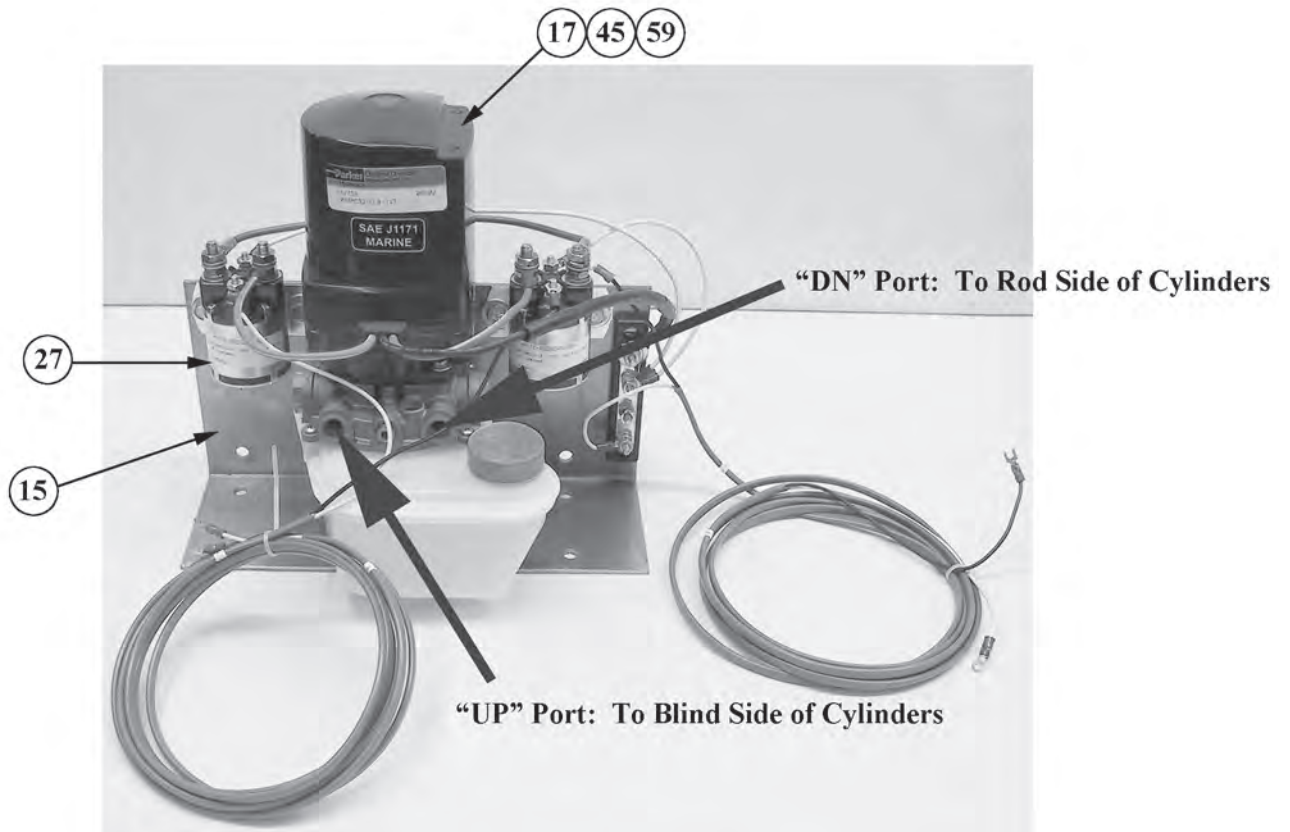

**12 VDC - 120 AMP FUSED
POWER CONNECTIONS**

POWER UNIT WITH BRACKET

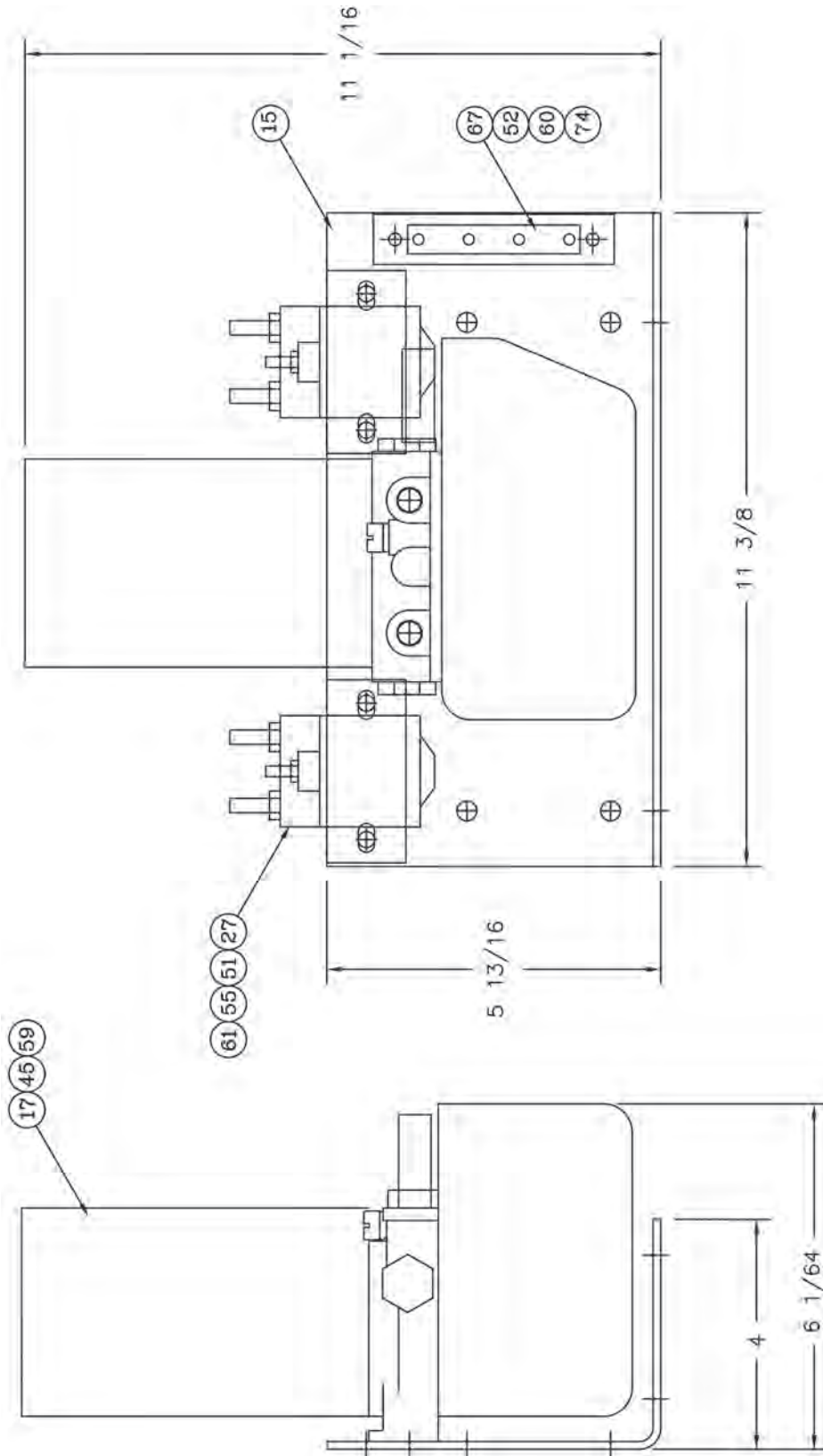

POWER UNIT WIRING

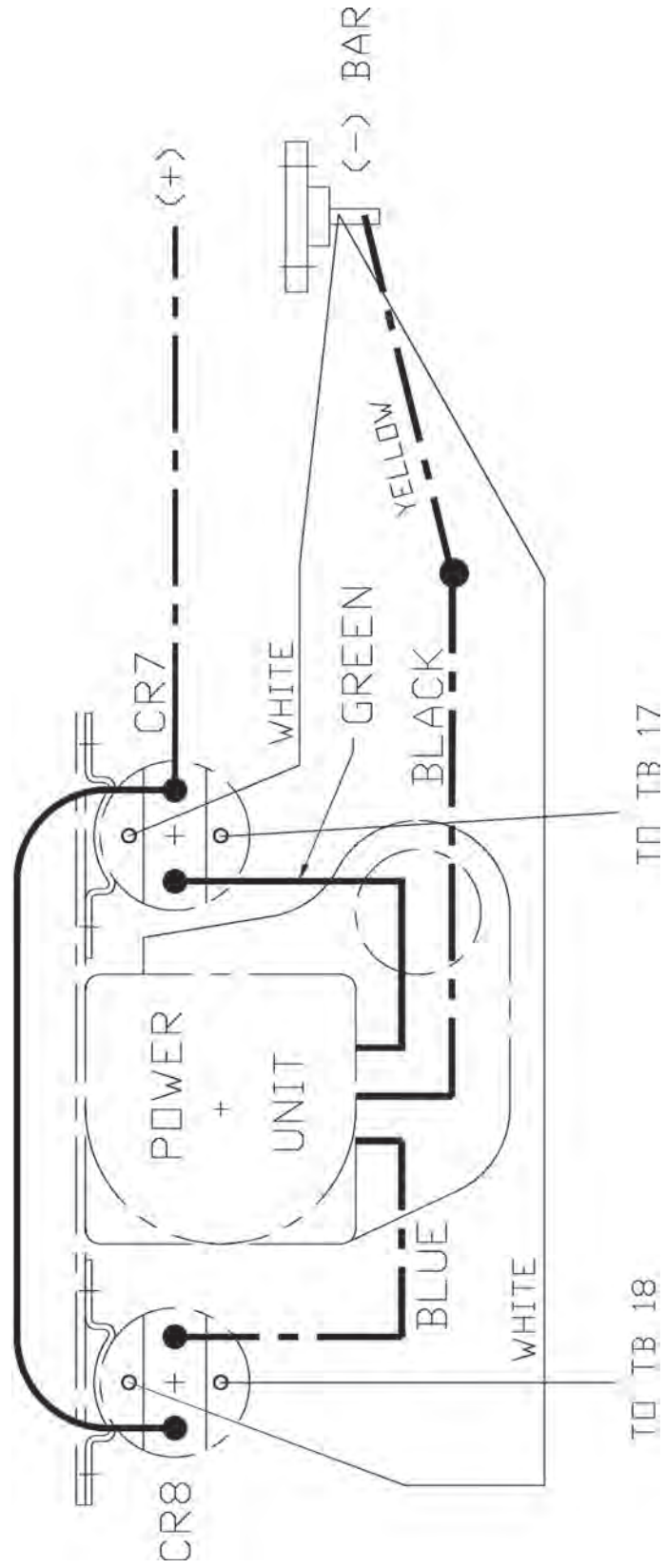

ELECTRICAL PANEL ASSEMBLY (28)

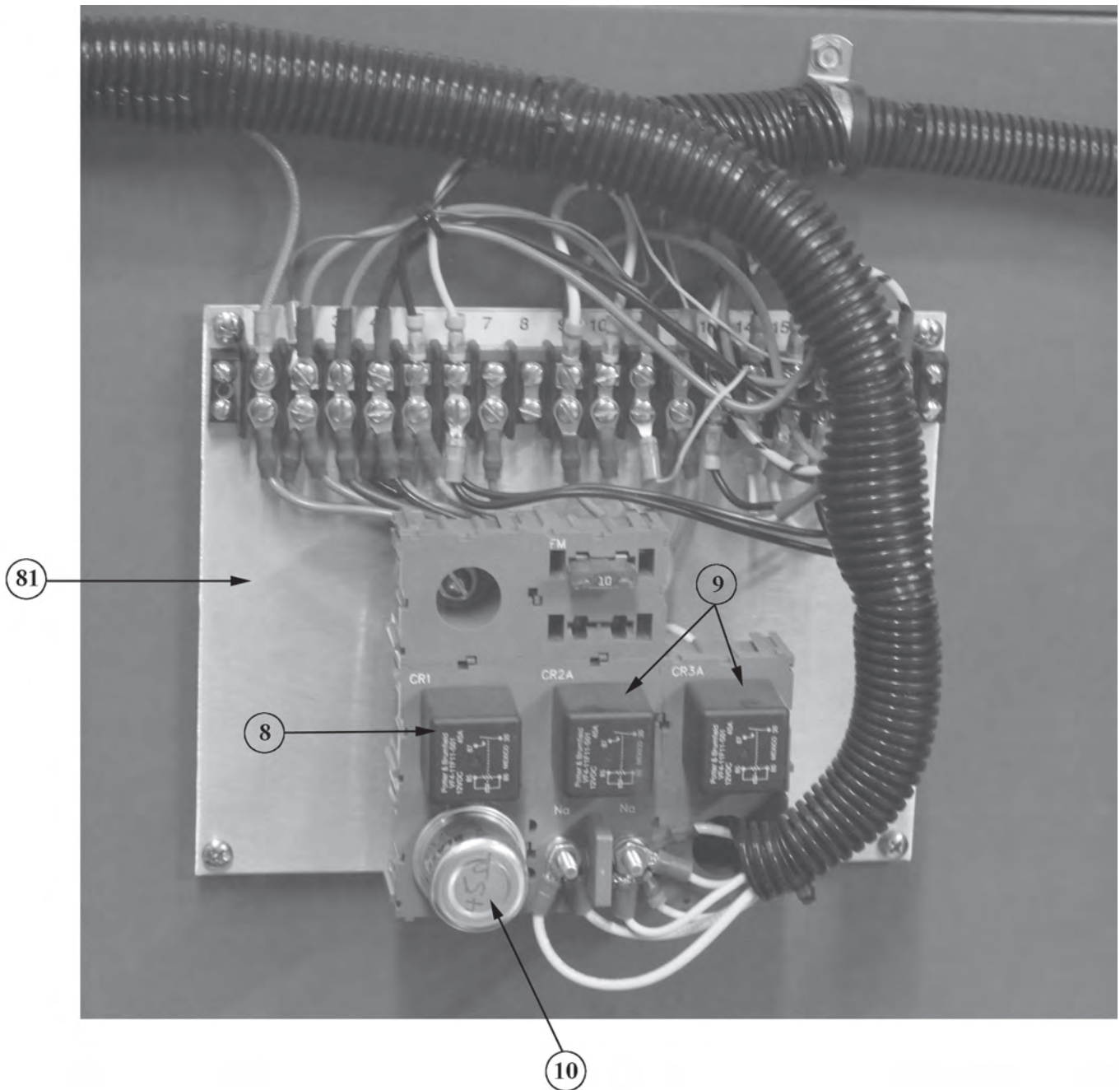

Note: Electrical panel should be mounted in waterproof compartment.

ELECTRICAL PANEL

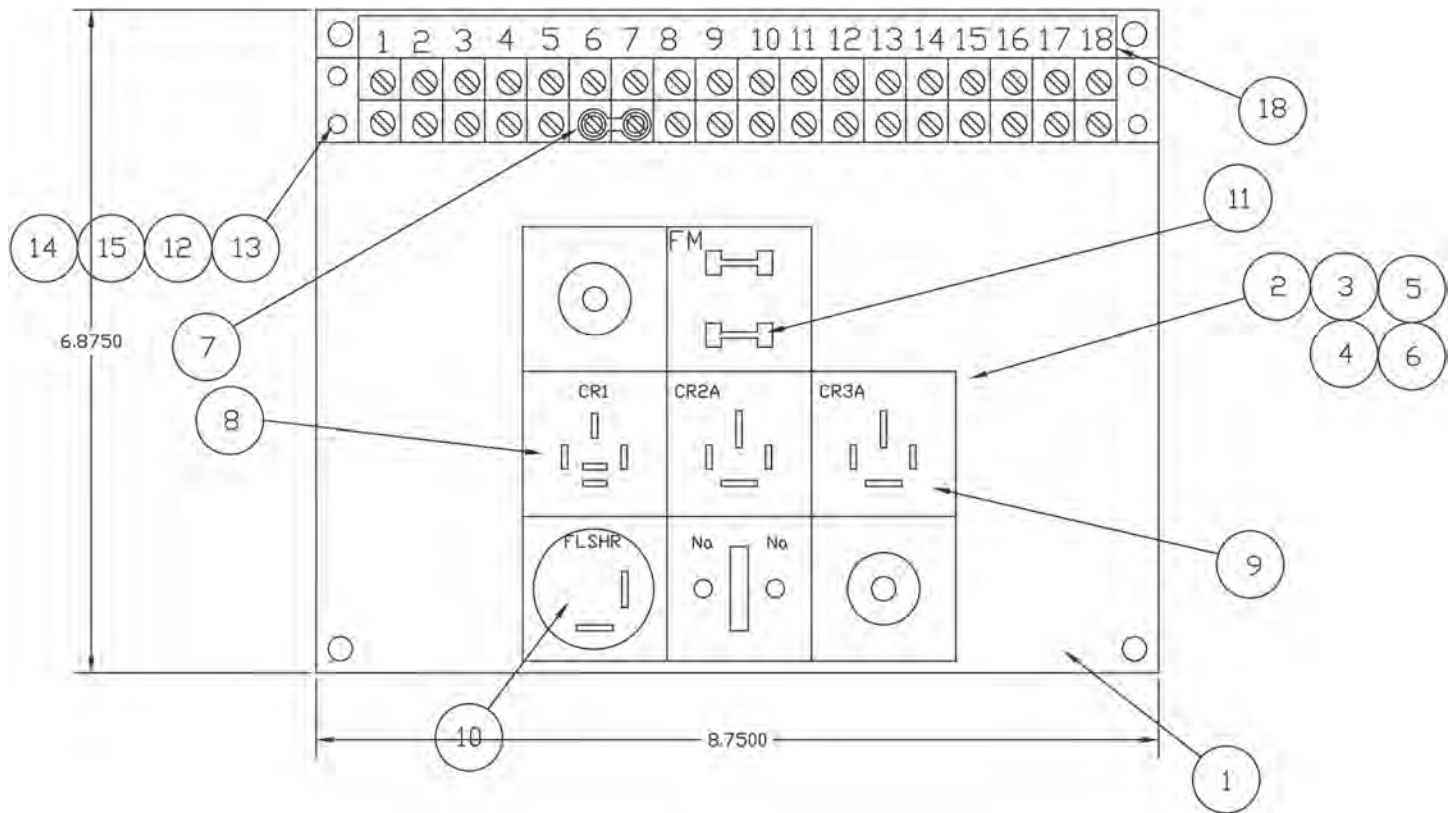

ELECTRICAL PANEL ASSEMBLY			
ITEM	PART NUMBER	DESCRIPTION	QTY.
1	3092-005-159	SUB-PANEL; 8.75 x 6.88	1
2		DIL-BLOX MODULE	1
3		STANDOFF #74096	2
4		SCREW, 10-32 x 1-1/2 PH	2
5		LOCKWASHER #10	6
6		HEX NUT, 10-32	6
7		JUMPER	1
8	3097-500-155	DOOR INTERLOCK RELAY CR1	1
9	3097-500-155	CONTROL RELAY CR2, CR3	2
10	3097-270-109	FLASHER	1
11		FUSE 10A	1
12		LOCKWASHER #6	4
13		HEX NUT, 6-32	4
14		TERM. BLOCK; 18 POS. CINCH 141 SERIES	1
15		SCREW, 6-32 x 5/8 RD. HD.	4
17		WIRING SET	1
18		TERMINAL LABEL	1
19		TERMINAL MARKING	1

WIRING DIAGRAM

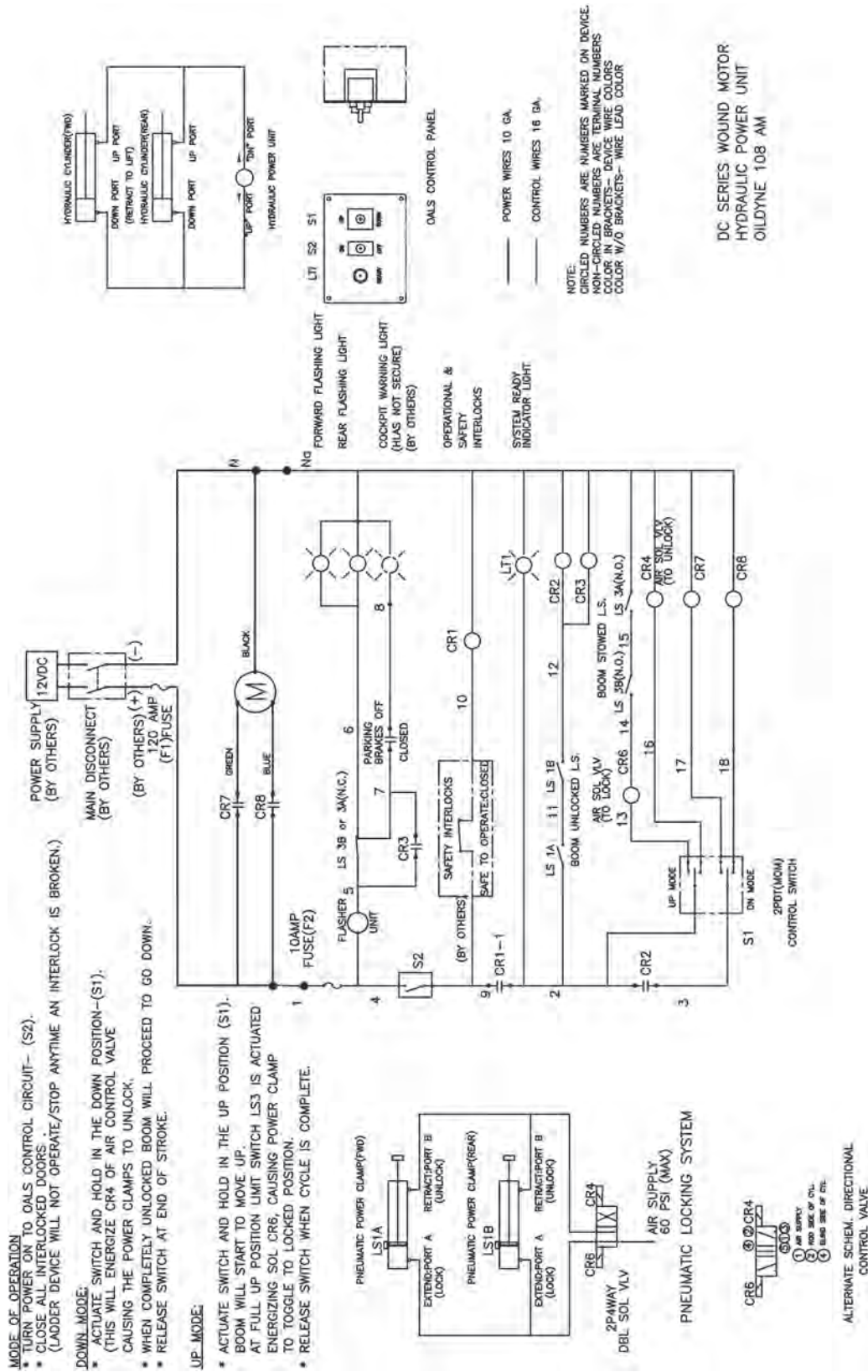

ELECTRICAL SCHEMATIC

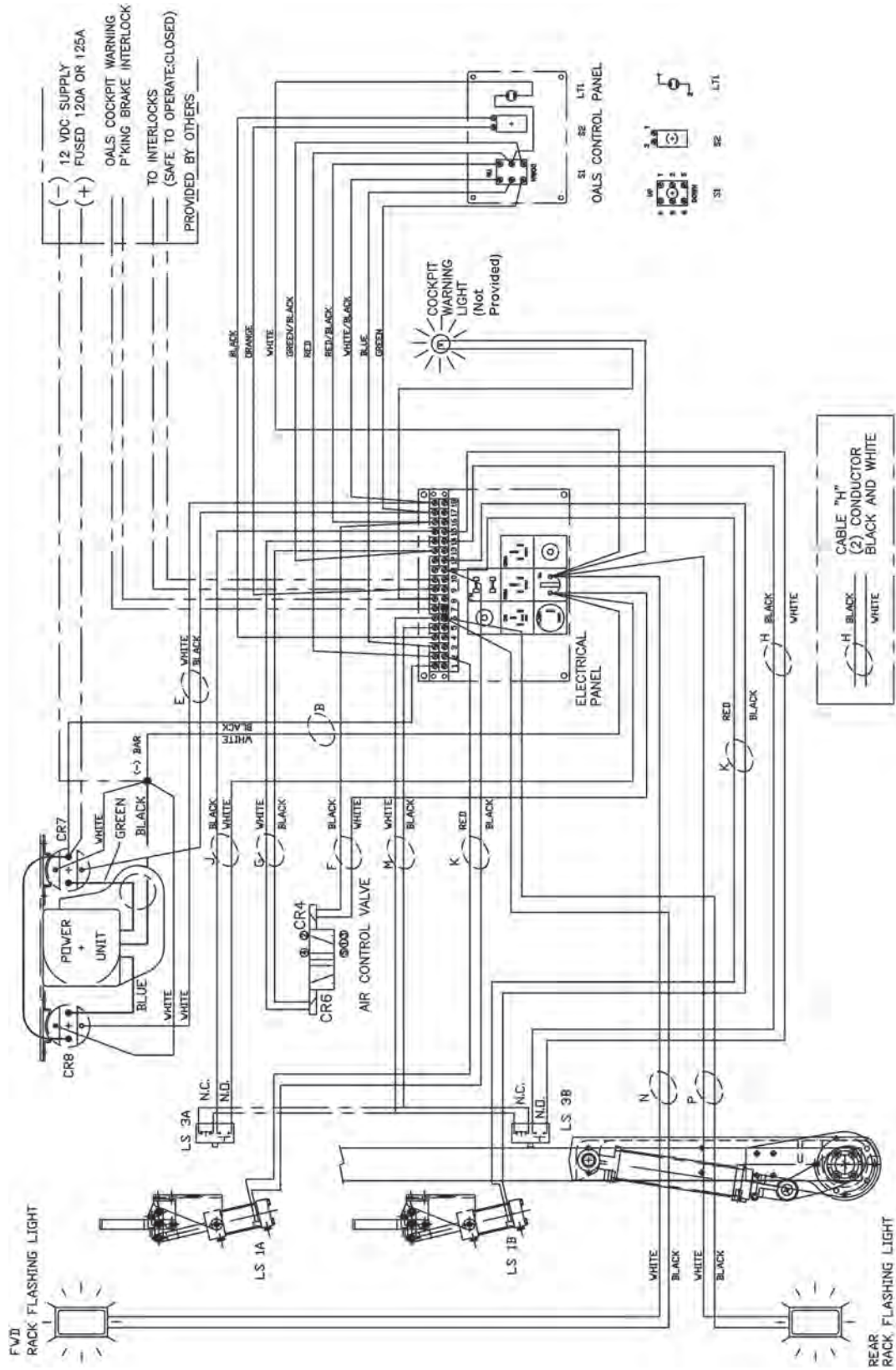

WIRING LIST

FROM	TO	END A	END B	WIRE SZ/COLOR/LGTH	QTY.
CR1-85	TB-N6	CODE A	CODE F	16GA./WHITE/5'	1
CR1-86	TB-10	CODE A	CODE B	16GA./YELLOW/6'	
CR1-87	TB-2	CODE A	CODE B	16GA./RED/6 1/2'	1
CR1-90	TB-9	CODE A	CODE B	16GA./DRNG/4'	
CR2-85	TB-N6	CODE A	CODE F	16GA./WHITE/5'	1
CR2-86	TB-12	CODE A	CODE B	16GA./YELLOW/4 1/2'	
CR2-87	TB-3	CODE A	CODE B	16GA./BLU/7'	1
CR2-30	TB-2	CODE A	CODE B	16GA./RED/7 1/2'	
CR3-85	TB-N6	CODE A	CODE F	16GA./WHITE/5'	1
CR3-86	TB-12	CODE A	CODE B	16GA./YELLOW/4'	
CR3-87	TB-7	CODE A	CODE B	16GA./RED/5 1/2'	1
CR3-30	TB-5	CODE A	CODE B	16GA./DRNG/6'	
F2-1	TB-1	CODE J	CODE B	16GA./RED/5'	1
F2-2	TB-4	CODE J	CODE B	16GA./BLACK/4'	
FL-1	TB-4	CODE A	CODE B	16GA./BLACK/6'	1
FL-2	TB-5	CODE A	CODE B	16GA./DRNG/6'	
TB-6	TB-7	-	-	JUMPER	
TB-N6	TB-N6	CODE F	CODE F	16GA./WHT/2'	

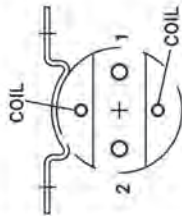

CR7 & CR8



WIRE HARNESS: SWITCH PANEL

FROM	TO	END A	END B	WIRE SIZE/COLOR/LGTH	PART NO.
LT1 *	S1-2	CODE B	CODE B	16GA./RED	3 1/2"
LT1-2	TB-N6	CODE B	CODE F	16GA./WHT	
S2-2	TB-9	CODE B	CODE H	16GA./ORANGE	
S2-1	TB-4	CODE B	CODE H	16GA./BLACK	9 COND. JACKETED
S1-1	TB-2	CODE B	CODE H	16GA./RED/BLACK	CABLE
S1-3	TB-13	CODE B	CODE H	16GA./GREEN/BLACK	14 1/2 FT.
S1-4	TB-18	CODE B	CODE H	16GA./WHITE/BLACK	
S1-5	TB-3	CODE B	CODE H	16GA./BLUE	
S1-6	TB-17	CODE B	CODE H	16GA./GREEN	BELDEN# 9621

CODE A: 250 FEM; FARGOW#30343

CODE B: RING 22-16GA./#6 NEWARK96F7159 TYP 34144

CODE C: 375 FEM; FARGOW#20437

CODE D: LUG 12-10GA./#10; NEWARK96F7912

CODE E: STRIP & TIN 3/16"

CODE F: RING16-14GA./#10; NEWARK96F7911

CODE G: STRIP & TIN 1/4"

CODE H: FLANGED 22-16GA./#6 NEWARK96F7279 TYP 322249

CODE J: FUSE TERM14-16GA./FARGOW 23433

CODE K: RING 12-10GA./ #31256

CODE L: RING 12-16GA./ #31256

CODE M: SNAP PLUG CONNECTOR 22-16 GA. (P/N 3097 270 115)

JUMPER: TYP 141J NEWARK 28F790

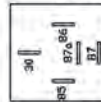

BOTTOM VIEW RELAY

EXTERNAL WIRING

ITEM	FROM	TO	DEVICE	END A	END B	GA./CLR./LGTH	PART NO.	QTY.
A	P.S.(+)	CR7-1	12VDC POWER SUPPLY	CODE D	CODE D	BY OTHERS		-
B	PSX (-)	(-)BAR		CODE K	CODE K	16GA./BLK		1
C	CR7-1	CR8-2		CODE H	CODE H	16GA./WHT	2 COND. CABLE 3097 510 110	12'
D	(-)STUD	TB-N6	POWER UNIT CONTACTORS	CODE F	CODE F	16GA./WHT/8"		1
E	CR8-COIL (-)BAR	CR7-COIL		CODE F	CODE F	16GA./WHT/16"		1
F	CR7-COIL	TB-17		CODE H	CODE H	16GA./BLK	2 COND. CABLE 3097 510 110	12'
G	CR8-COIL	TB-18		CODE H	CODE H	16GA./WHT		1
H	PUGLND	CR8-1	POWER UNIT	CODE K	CODE K	12' LG. UNIT PIGTAIL		-
I	PUGBLKO	CR7-2		CODE K	CODE K			-
J	CR4-1	TB-16	AIR SOLENOID VALVE	CODE E	CODE E	16GA./BLK	2 COND. CABLE 3097 510 110	12'
K	CR6-1	TB-13		CODE E	CODE E	16GA./BLK	2 COND. CABLE 3097 510 110	12'
L	CR6-2	TB-14		CODE E	CODE E	16GA./WHT	2 COND. CABLE 3097 510 110	12'
M	LS3B-3	TB-15	ROOM STOVED	CODE G	CODE G	16GA./BLK	2 COND. CABLE 3097 510 110	20'
N	LS3A-4	TB-N6	LIMIT SWITCHES	CODE G	CODE G	16GA./WHT	2 COND. CABLE 3097 510 110	20'
O	LS1A-1	TB-2	ROOM UNLOCKED	CODE H	CODE H	2 FT. PIGTAIL		-
P	LS1A-2	TB-11	LIMIT SWITCHES	CODE H	CODE H	2 FT. PIGTAIL		-
Q	LS1B-2	TB-12		CODE H	CODE H			-
R	NC-2	TB-6	NFPA LIMIT SV. LS3A OR LS3B	CODE G	CODE G	16GA./BLK	2 COND. CABLE 20'	
S	FWD LT	TB-6	RACK FORWARD	CODE H	CODE H	16GA./BLK	2 COND. CABLE 20'	
T	FWD LT	TB-N6	FLASHING LIGHTS	CODE M	CODE M	16GA./WHT	2 COND. CABLE 20'	
U	RR LT	TB-6	RACK REAR	CODE H	CODE H	16GA./BLK	2 COND. CABLE 20'	
V	RR LT	TB-N6	FLASHING LIGHTS	CODE M	CODE M	16GA./WHT	2 COND. CABLE 20'	
W	DOOR	TB-9	DOOR	CODE H	CODE H	BY OTHERS		-
X	SWITCH	TB-10	INTERLOCKS	CODE H	CODE H			-
Y	PIKING	TB-7	PARKING BRAKES	CODE H	CODE H	BY OTHERS		-
Z	BRKES	TB-8	INTERLOCK	CODE H	CODE H			-
AA	COCKPIT	TB-8	DALS NOT SECURE	CODE H	CODE H	BY OTHERS		-
AB	LIGHT	TB-N6	WARNING	CODE F	CODE F			-

16GA LEAD WIRE BELDEN HOOK UP WIRE TYPE 9916 SOURCE: NEWARK

SWITCH PANEL ASSEMBLY (36)

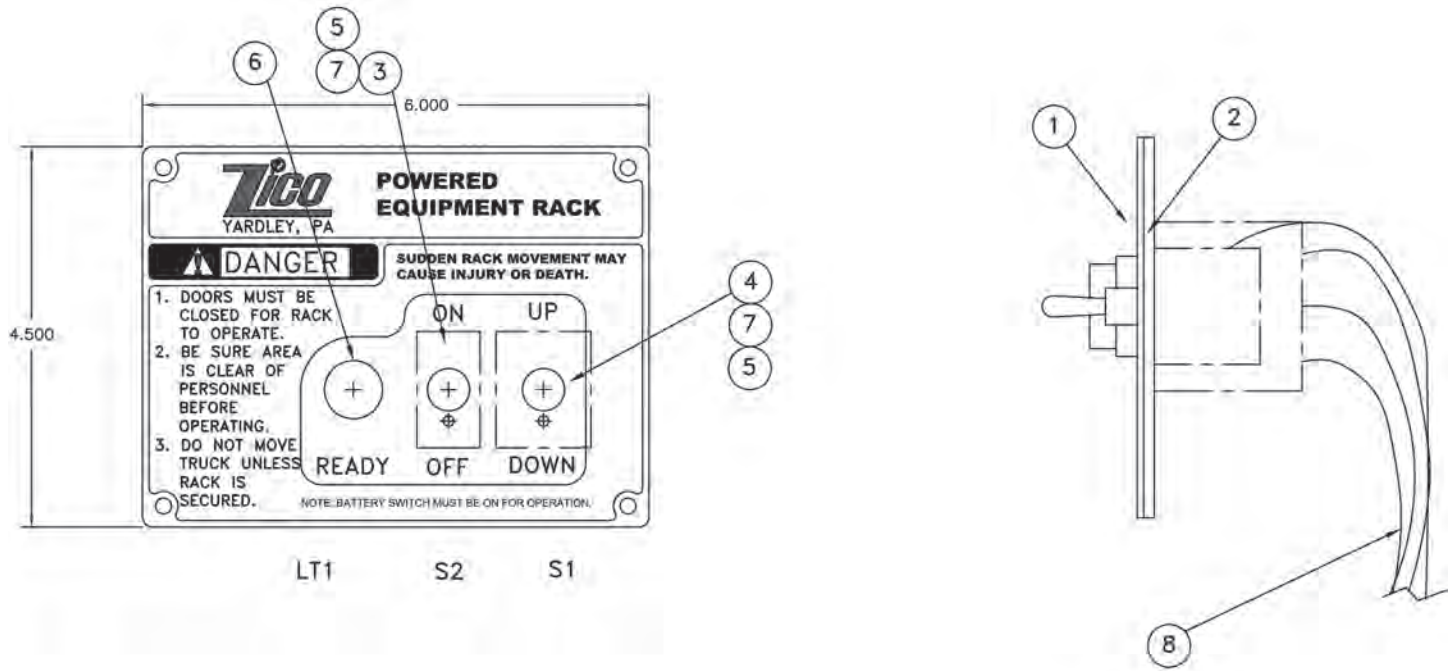

ELECTRICAL SWITCH PANEL			
ITEM	PART NUMBER	DESCRIPTION	QTY.
1	3097-500-179	NAMEPLATE, SWITCH	1
2	3097-500-178	MOUNTING PLATE, SWITCH	1
3	3097-500-157	POWER SWITCH (ON/OFF)	1
4	3097-500-156	CONTROL SW> (UP/DOWN) S1	1
5	3097-105-145	BOOT, TOGGLE SWITCH	2
6	3097-500-169	INDICATOR LIGHT (READY LIGHT)	1
7	3097-105-146	LOCKING RING TYPE 29-761-5	2
8		WIRING HARNESS (14 FT)	1

LIGHTING KIT COMPONENTS

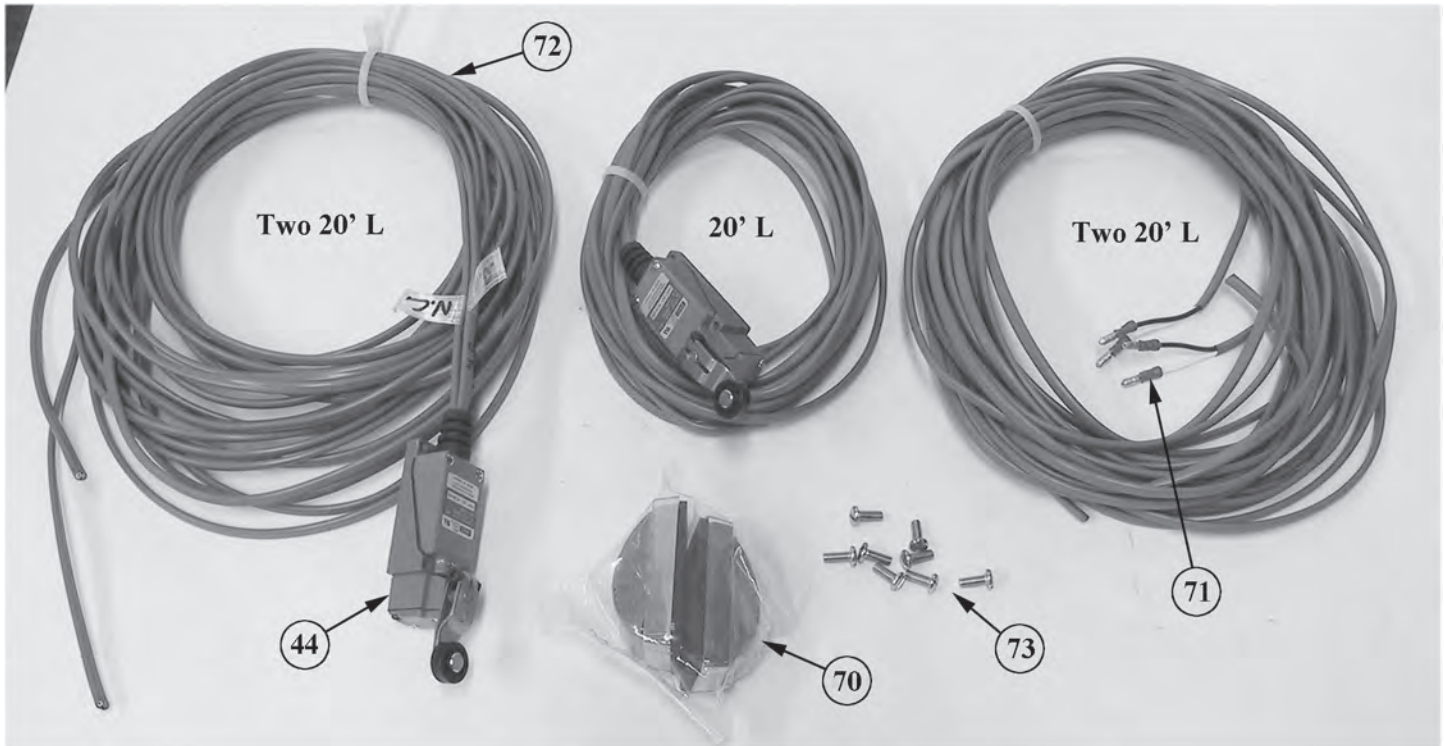

NOTE: Limit Switch (44) attaches to Boom Stop Bracket (14) with Screw (52).

NOTE 2: #4-40 screws are provided with clearance lights for mounting.

POWER CLAMP COMPONENTS

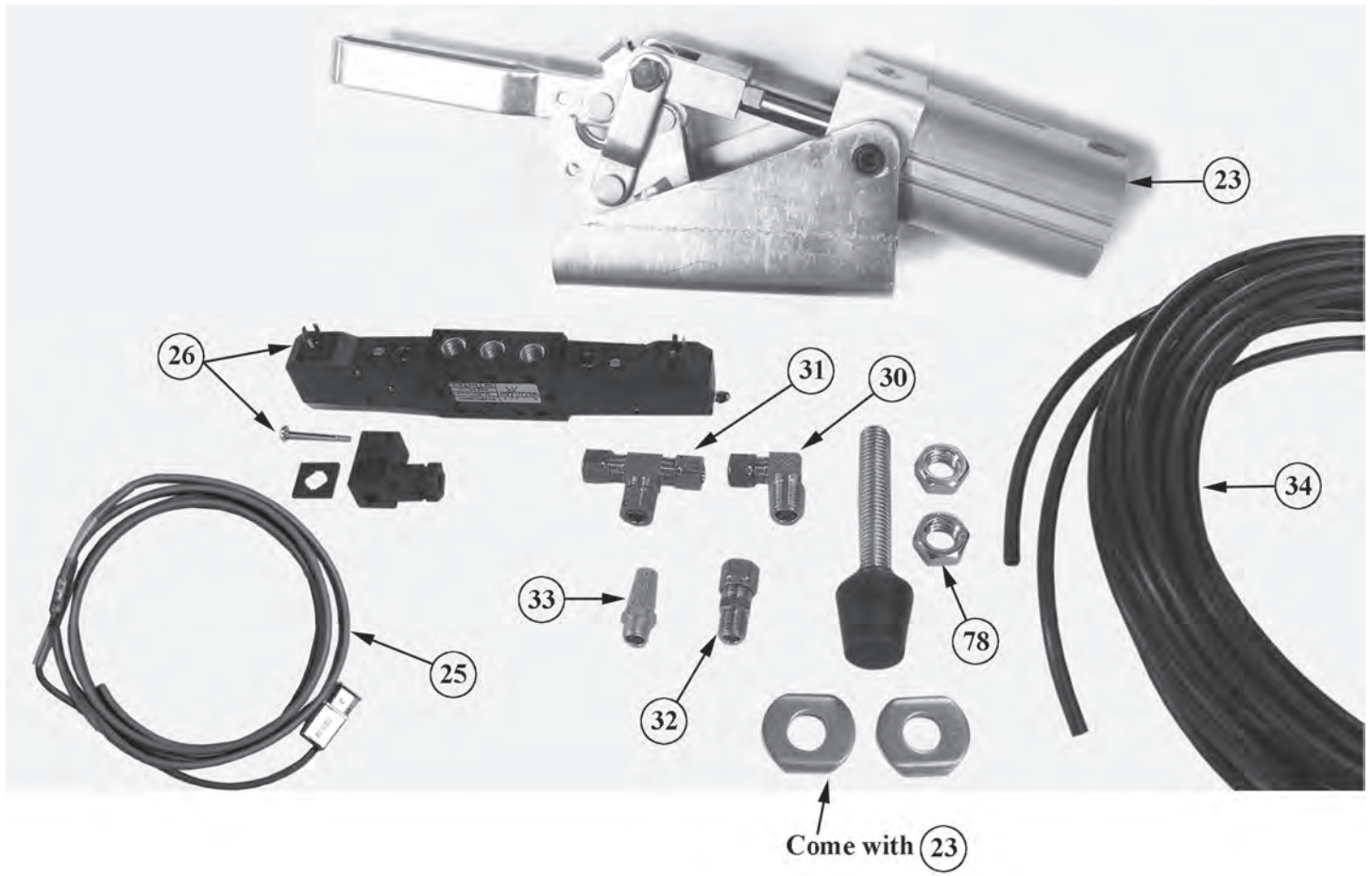

POWER CLAMP - MOUNTED ON BRACKET

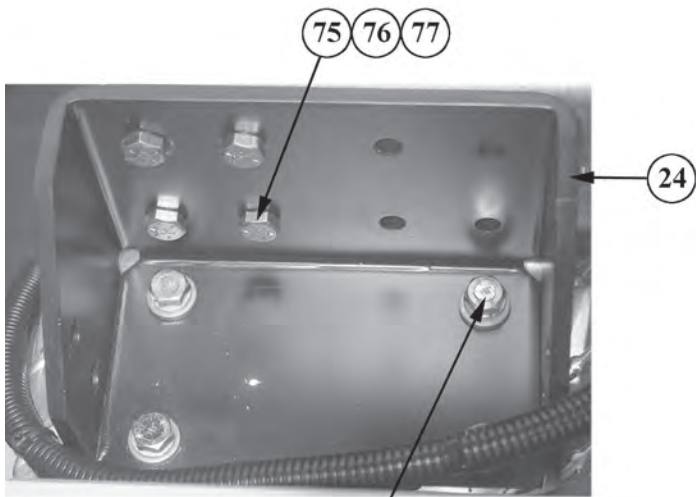
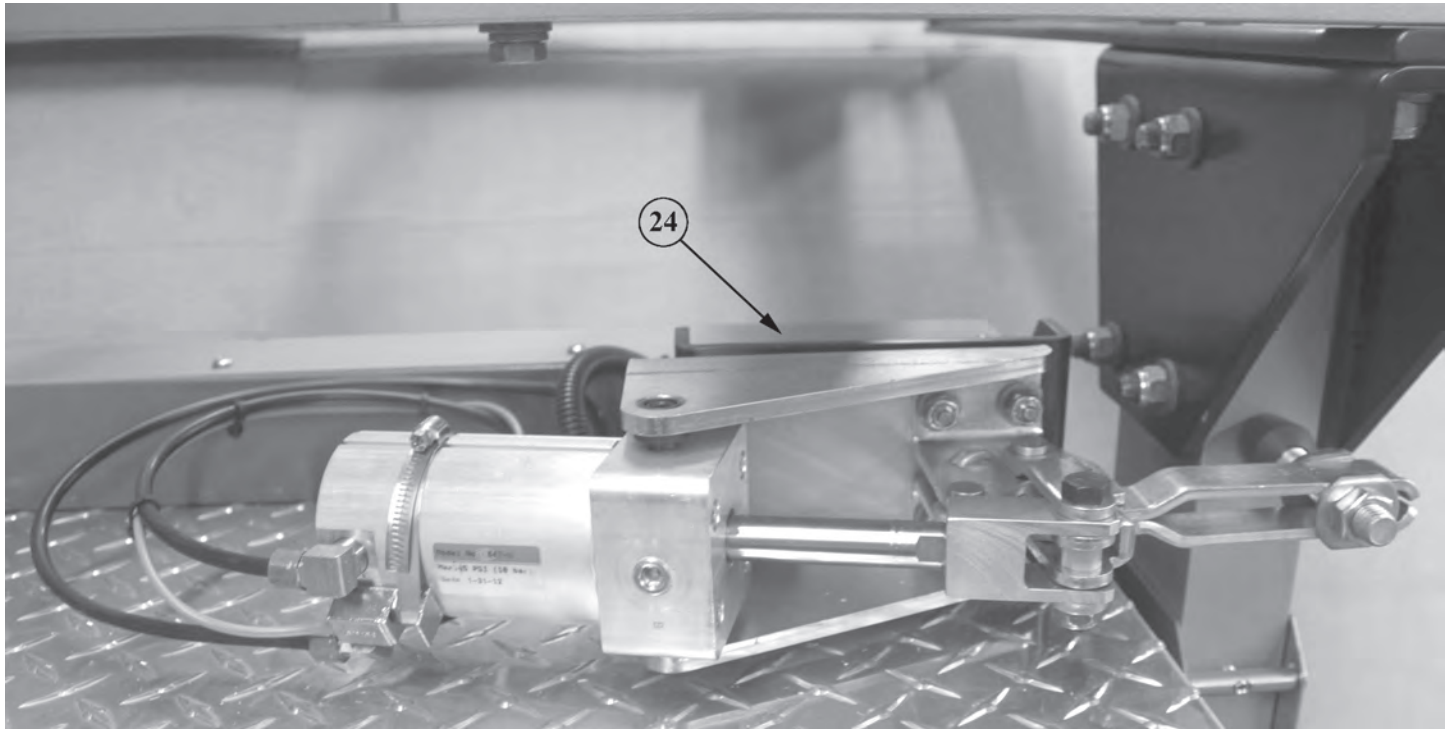

Mounting bolts not provided

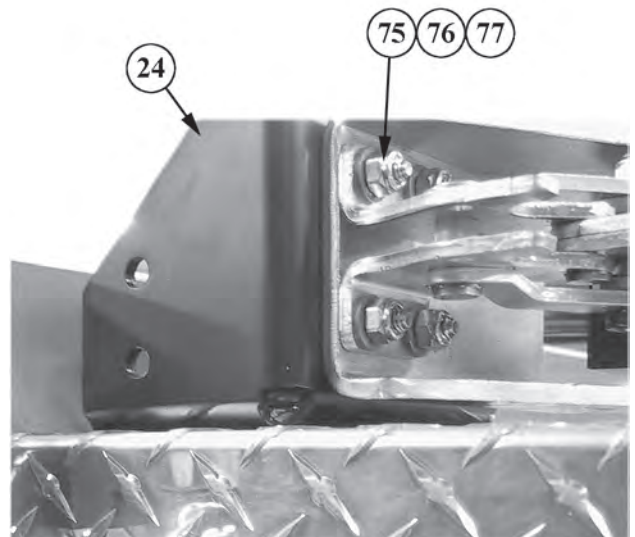

AIR CONTROL VALVE AND COMPONENTS

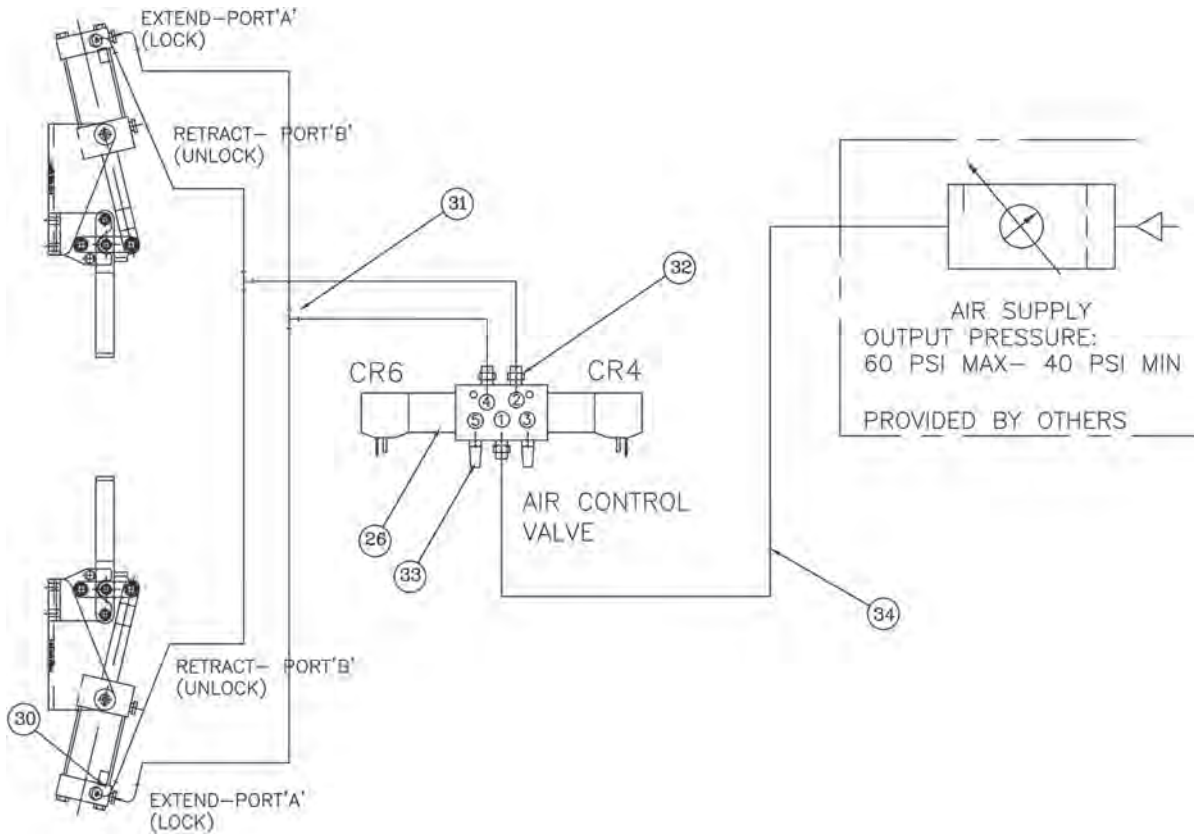
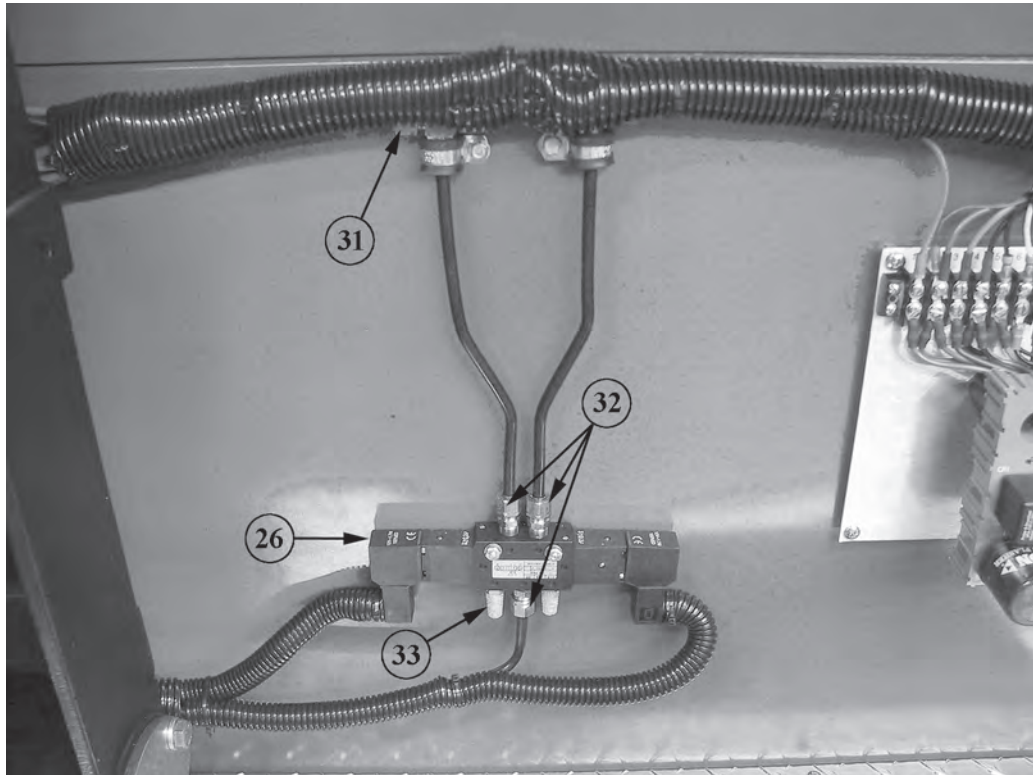

OALS RACK - PARTS DIAGRAM/BREAKDOWN

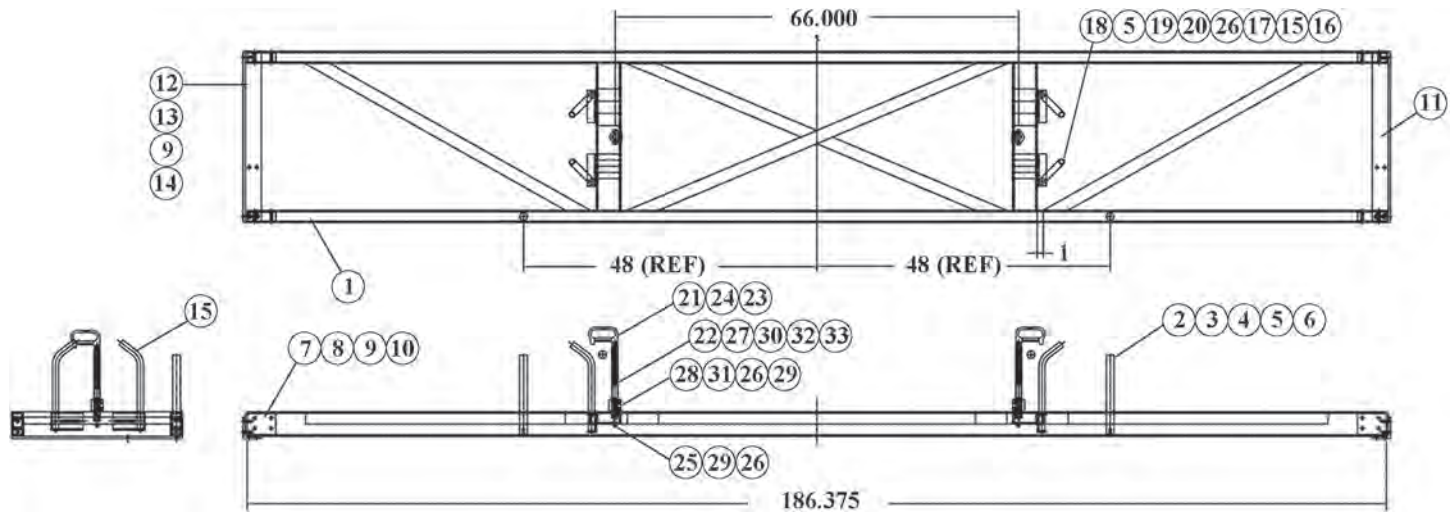

ITEM NO.	PART NO.	DESCRIPTION	QTY.
1	3092-050-101	RACK WELDMENT	1
2	3092-050-103	SIDE POST, 1-1/4 ϕ x 13" LG. ALUM. ROD	2
3	3092-050-105	RUBBER SLEEVE, 1-1/4 ϕ x 9-1/4" LG.	2
4	9010-103720	SCREW, 3/8-16 x 1-1/4, HH, ZPS	2
5	9014-113700	FLATWASHER, 3/8 ID SZP	10
6	9014-203700	LOCKWASHER, 3/8 NOM. ϕ , SPLIT	2
7	3092-050-107	MOUNTING BLOCK, RACK	4
8	9018-104444	SCREW, 7/16-20 x 2-3/4, HEX HD. GR 8 (RAIL TO MOUNTING BLOCK)	16
9	9014-114300	FLATWASHER, 7/16 NOM. ϕ	32
10	9013-254300	NUT, 7/16-20, HEX SELF LOCKING	16
11	3092-050-109	ADAPTER ANGLE, RH., 3 x 3-1/2 x 3/8 CRS	1
12	3092-050-111	ADAPTER ANGLE, LH., 3 x 3-1/2 x 3/8 CRS	1
13	9018-104324	SCREW, 7/16-14 x 1-1/2, HEX HD. GR 8 (ANGLE TO MOUNTING BLOCK)	8
14	9014-204300	LOCKWASHER, 7/16 SPLIT	8
15	3092-050-142	LADDER SAFETY LOOP MEDIUM LENGTH	4
	3092-050-141	LADDER SAFETY LOOP FULL LENGTH	
16	3092-015-116	SLEEVE, LADDER SAFETY LOOP, (MEDIUM) 11.5" L	4
	3092-020-116	SLEEVE, LADDER SAFETY LOOP, (LONG) 13.75" L	
17	3097-500-418	MOUNTING BRACKET, SAFETY LOOP	4
18	9018-103778	SCREW, 3/8-16 x 4-7/8, HEX HD GR 8 (SAFETY LOOP BRACKET)	8
19	9013-133700	NUT, 3/8-16, HEX, SELF LOCKING	8
20	9018-163112	SCREW, 5/16-18 x 1-3/4 LG, FH SZP GR 8 MMC 91253A589 (SAFETY LOOP)	4
21	3097-105-109	HANDLE, LADDER RETAINER	2
22	3097-105-125	RETAINER HOUSING, SHORT LENGTH 6.12" L	2
	3097-165-125	RETAINER HOUSING, MEDIUM LENGTH 8.25" L	
	3097-145-125	RETAINER HOUSING, FULL LENGTH 10.50" L	
23	3097-105-113	COMPRESSION SPRING	2
24	9010-3350104	SCREW, SOCKET HEAD, 1/2-13 x 6-1/2	2
25	9018-103172	SCREW, 5/16-18 x 4-1/2 SOCKET HD. GR 8 (RETAINER)	4
26	9113-133100	NUT, 5/16-18, HEX, SELF-LOCKING, SS	8
27	3097-105-118	SETSCREW, 7/8-14 HOLLOW LOCK	2
28	3097-105-126	SUPPORT, RETAINER HANDLE	2
29	9014-203100	LOCKWASHER, 5/16 NOM. ϕ SPLIT	4
30	3097-105-121	RET. RING	2
31	9010-333132	SCREW, 5/16-18 x 2 SOCKET HD. (RETAINER SUPPORT)	4
32	3097-105-130	WASHER, NYLON, 1/2 ID x 3/4 OD	2
33	3097-105-160	WEAR STRIP, PLASTIC	2

OALS RACK COMPONENTS

NOTE: Numbers correspond to OALS Rack parts breakdown on page 38.

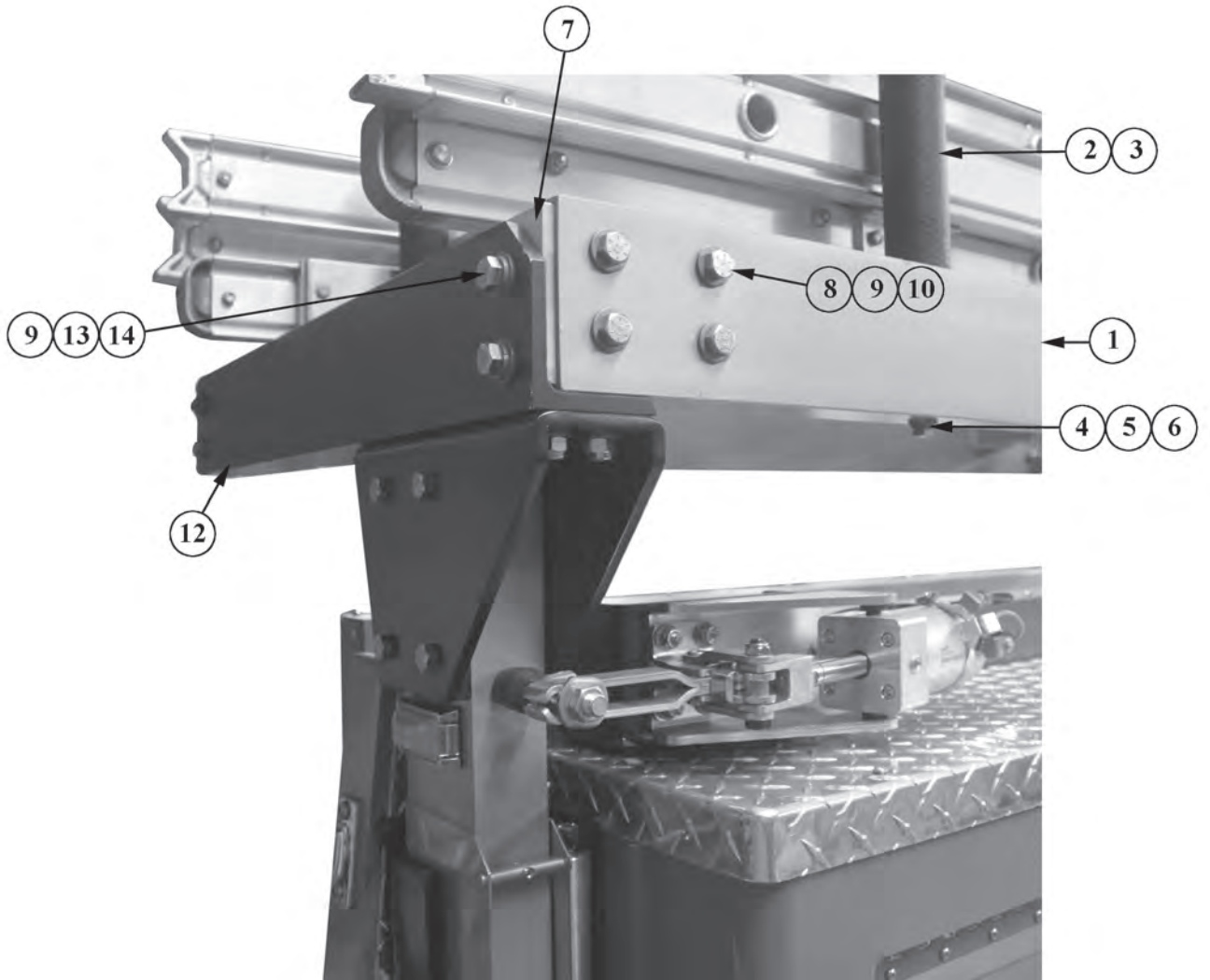

OALS RACK - SAFETY LOOP COMPONENTS

NOTE: Numbers correspond to OALS Rack parts breakdown on page 38.

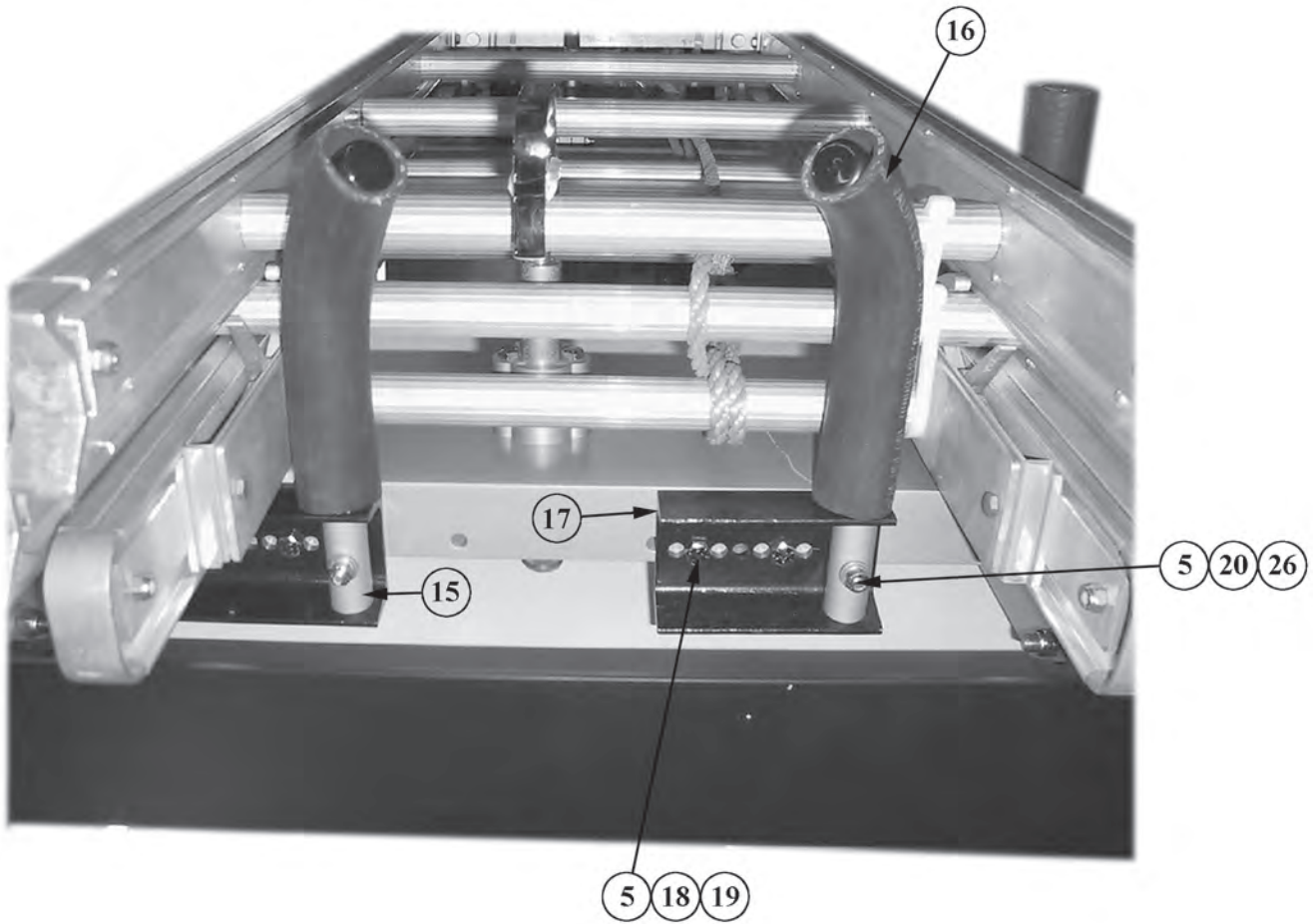

OALS RACK - HANDLE ASSEMBLY

NOTE: Numbers correspond to OALS Rack parts breakdown on page 38.

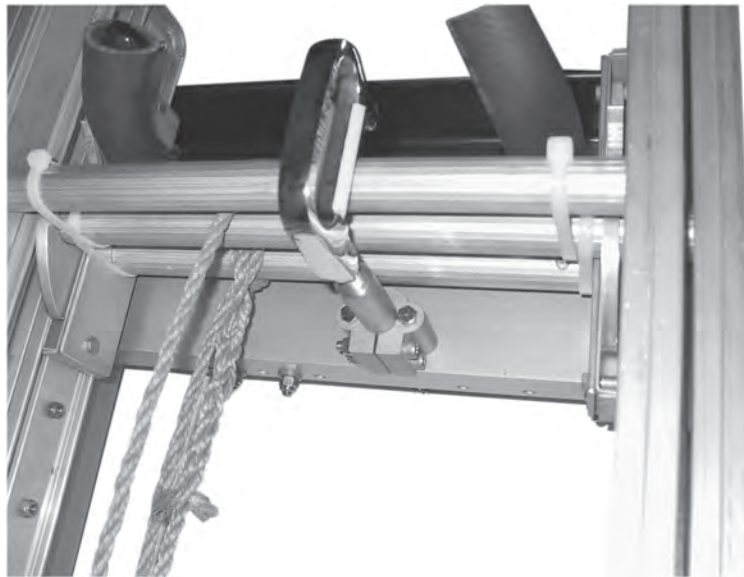
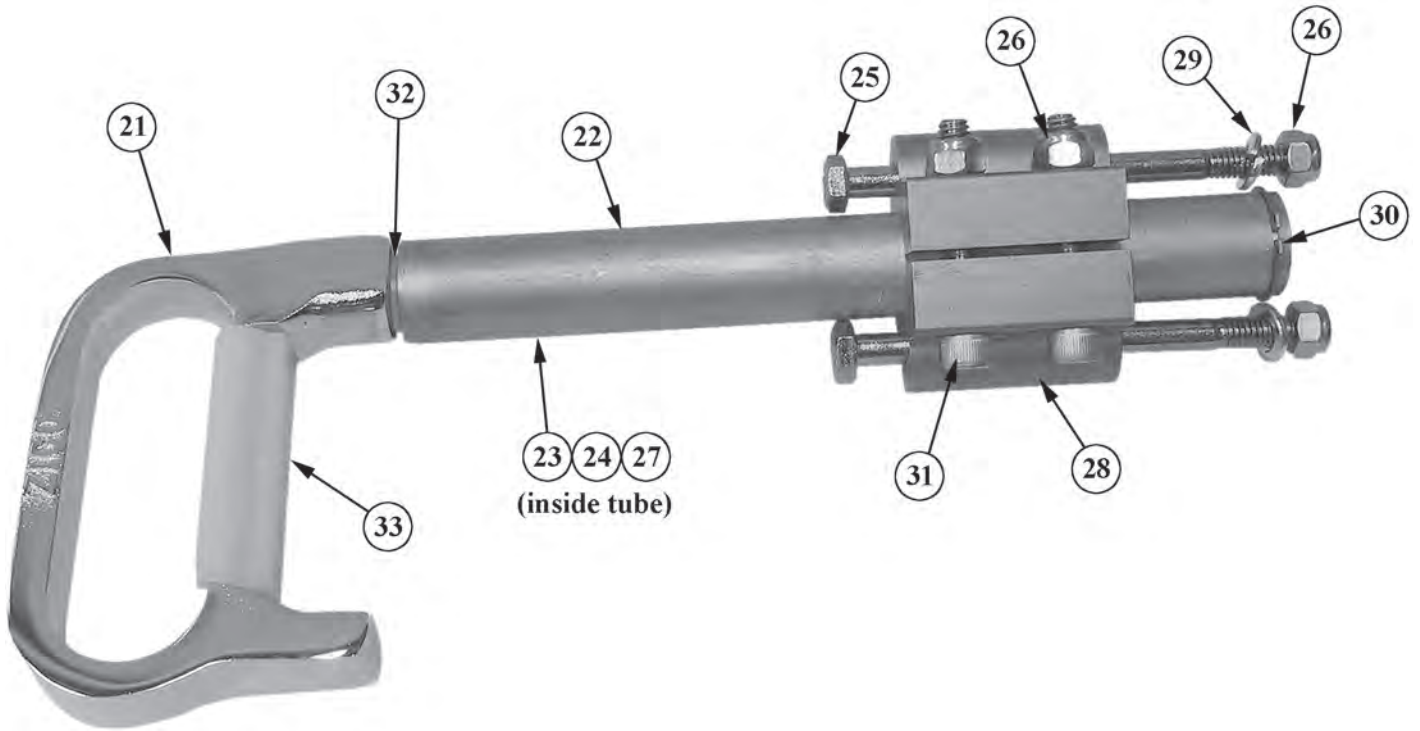



Hands and arms may be crushed between the boom and truck body. Keep clear of this area when operating the ladder access system. Always wear protective gear when working around system.



Keep clear of area when raising or lowering ladder access system to prevent striking injury. Always wear full protective clothing including helmet when working around system.



Loss of hydraulic fluid may cause ladder access system to drop rapidly. Severe injury may result. Never operate system when hydraulic fluid is leaking. Consult operator's manual prior to removing any hydraulic fittings. Always wear protective equipment when working around system.



Ziamatic Corp.

10 West College Avenue, P.O. Box 337, Yardley, PA 19067-0587 • (215) 493-3618 • FAX: (215) 493-1401

www.ziamatic.com

TOLL FREE: 800-711-3473

*ZICO is a registered trademark for fire, safety and marine products made by Ziamatic Corp.

Copyright Ziamatic Corp. 12-16

WARRANTY REGISTRATION

PLEASE MAIL OR FAX A COPY TO **ZICO** TO REGISTER YOUR UNIT

Fire Department Name: _____

Contact Person: _____ Phone: _____ Fax: _____

Street Address: _____ P.O. Box _____

City: _____ State: _____ Zip: _____ - _____

Model No.: (check one) _____ OALS-775 _____ OALS-975 _____ OALS-1200

Serial No.: (see Fig. ____, page ____) _____

Installed On: (vehicle mfg.) _____ Delivered: (date) _____

Was Unit Installed On: _____ New Vehicle or _____ Retrofitted onto Existing Vehicle

Ladders Mounted on this System:

Duo-Safety _____ ft. extension, model _____ Alco-Lite _____ ft. extension, model _____

Duo Safety _____ ft. roof, model _____ Alco-Lite _____ ft. roof, model _____

Duo Safety _____ ft. _____, model _____ Alco-Lite _____ ft. _____, model _____

Other Manufacturer:

_____ ft. extension, model _____

_____ ft. roof, model _____

_____ ft. _____ model _____

Where Did You Hear About Our Product?

_____ Magazine Advertisement (specify) _____

_____ Dealer (specify) _____

_____ Vehicle Mfg. (specify) _____

_____ Other (specify) _____