

**QUIC-RELEASE® SLIDE ASSEMBLY**  
**MODEL QR-SA**  
**PARTS AND INSTRUCTION MANUAL**

**3030PM13**

NOTE: This mounting device has been designed for use with QUIC-RELEASE gas cylinder brackets, Models QR-M-2, QR-GH, and QR-MV, which must be ordered separately.

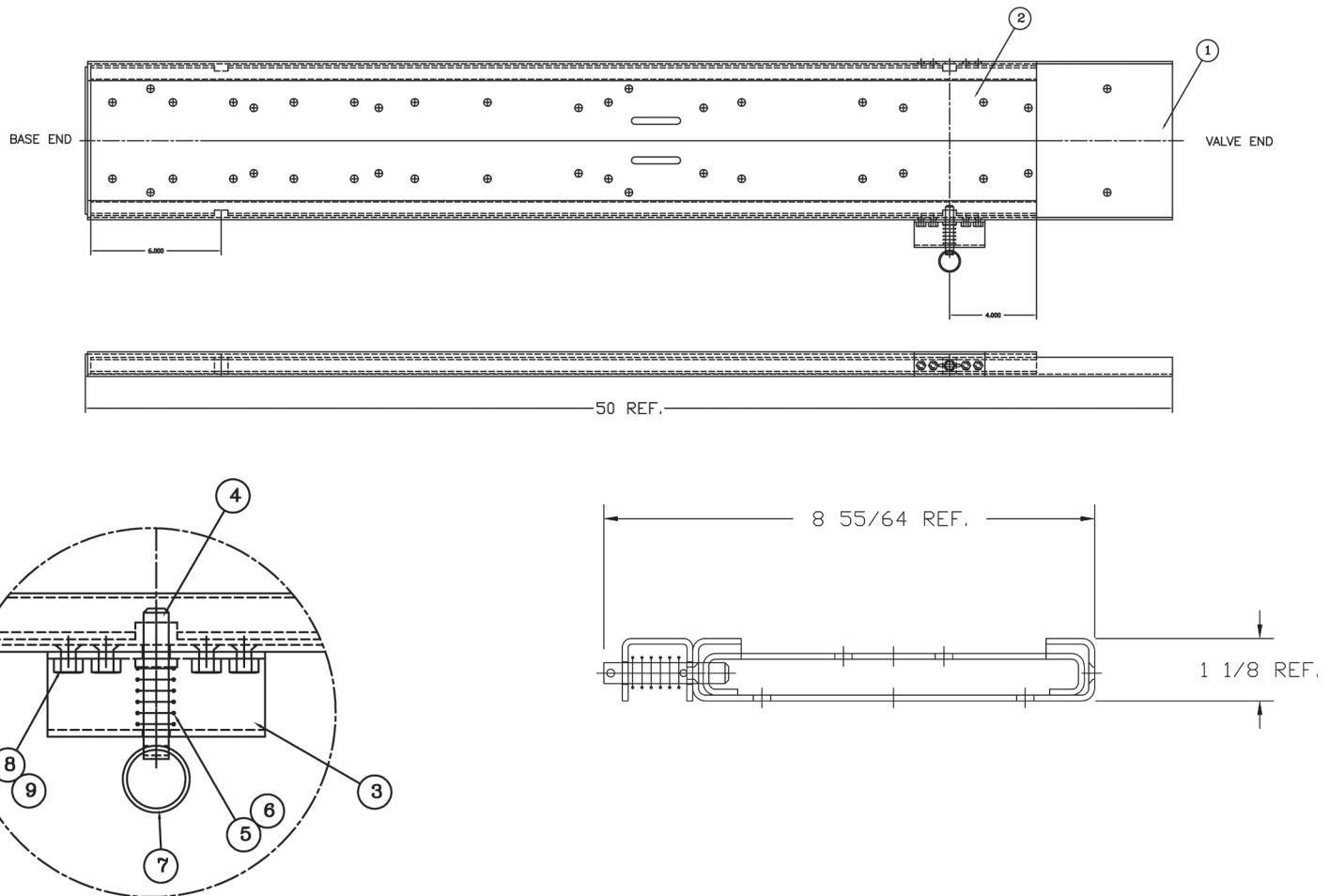

ITEM NO.	PART NO.	DESCRIPTION	QTY.
1	3030-130-105	Base	1
2	3030-130-110	Slide	1
3	3030-130-112	Lock Bracket	1
4	3030-130-115	Lock Pin	1
5	3030-130-120	Spring	1
6	9040-111212	Roll Pin 1/8ø x 3/4" LG. SS	1
7	0000-000-123	Key Ring, .142 Thk. x 1.48 OD ZP MMC 90177A223	1
8	9010-162008	Screw, 10-32 x 1/2 FH, 100°	4
9	9013-172000	Hex Nut, 10-32, Self Locking	4

## Assembly Instructions - Horizontal Position

---

**Note:** Numbers in parentheses correspond to numbers in Parts List for ease of assembly.

1. Attach QUIC-RELEASE gas cylinder bracket (either Model QR-M-2, QR-GH, or QR-MV) to sliding tray (2) using 5/16-18 Hex bolts and nuts as provided. Nuts should be threaded to bolts on underside of sliding tray.
2. Place empty gas cylinder in bracket and secure. Fasten gate at neck of cylinder.
3. Place assembled unit in desired storage area. To check for proper fit, mark the location of the base within the storage area.
4. Pull lock pin (4) and completely remove the sliding tray (2) from the base section (1).
5. Position base (1) into previously marked position. Using holes in the base section (1) as a template mark and drill six 11/32" diameter holes.
6. Attach base (1) to mounting surface using 5/16" bolts and nuts (bolts not provided).
7. Replace sliding tray (2) into the base section (1).

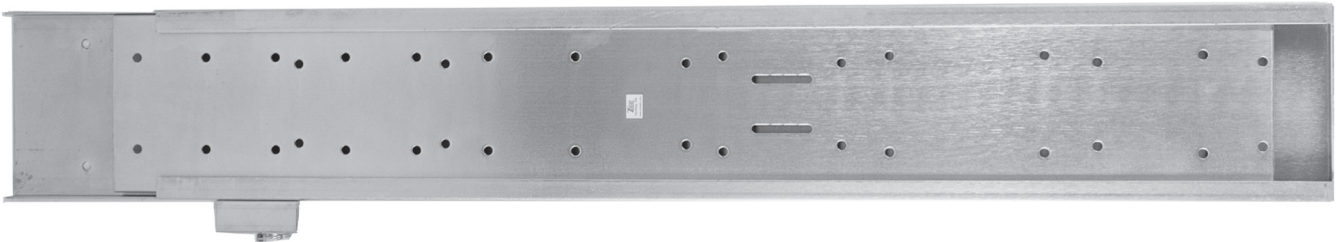

*Ziamatic Corp.*

10 West College Avenue, P.O. Box 337, Yardley, PA 19067-0587 • (215) 493-3618 • FAX: (215) 493-1401

[www.ziamatic.com](http://www.ziamatic.com)

TOLL FREE: 800-711-3473

\*ZICO is a registered trademark for fire, safety and marine products made by Ziamatic Corp.

Copyright Ziamatic Corp. 4-11