

QUIC-CHOC® SAFETY LATCH MODEL QCH-SL

The QUIC-CHOC® Safety Latch is designed to prevent accidental loss of your wheel choc.

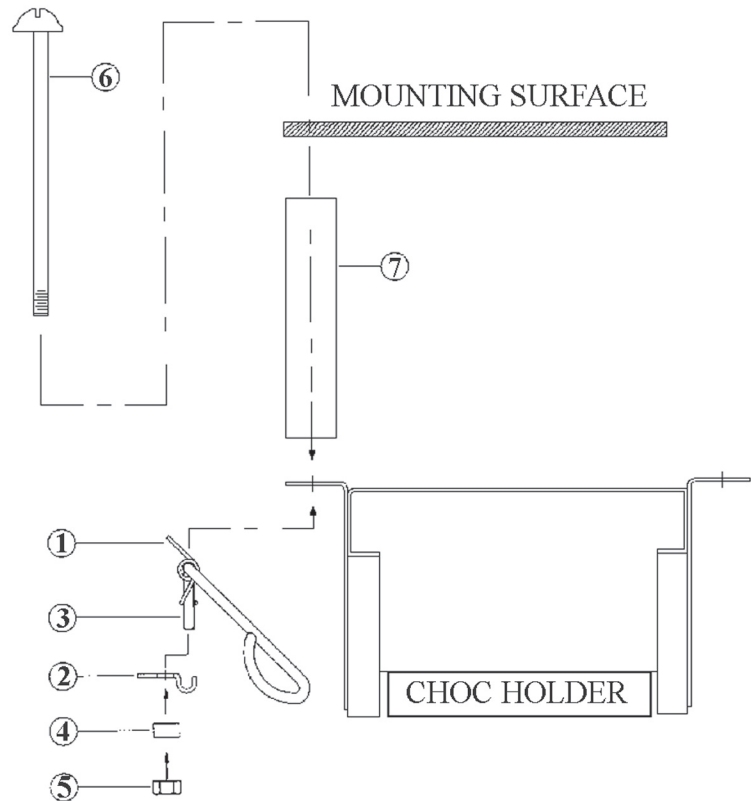

May be attached to our standard Model QCH-1, QCH-2 and QCH-32-H horizontal holders.

Simple to install.

Swing the latch rod to the left while removing or replacing the choc.

ITEM NO.	PART NO.	DESCRIPTION	QTY.
1	3025-235-105	Torsion Spring	1
2	3025-235-110	Hinge Stamping	1
3	3025-235-115	Wire Form Rod	1
4	3025-235-120	Spacer	1
5	9012-102500	1/4-20 Hex Head Nut	1
6	9010-232572	1/4-20 x 4-1/2" Rd. Head Screw	1
7	3025-000-110	4" Plastic Tube	1

Note: Items 5, 6 & 7 are shipped with the horizontal mounting bracket and are noted here to show possible mounting positions.



Ziamatic Corp.

10 West College Avenue, P.O. Box 337, Yardley, PA 19067-0587 • (215) 493-3618 • FAX: (215) 493-1401

www.ziamatic.com

TOLL FREE: 800-711-3473