

QUIC-STEP® RETRACTABLE VEHICLE STEP**MODEL VS-20-5****PARTS AND INSTRUCTION MANUAL****Model VS-20-5 Specs:**

- 20" W x 5" D non-skid stepping surface
- 6" drop
- Sustains a static load of 500lbs.
- Meets NFPA 1901-09 requirements for slip resistance and static load
- Only requires 24" W x 9" D mounting surface
- Only requires 2-1/2" drop mounting flanges to clear components
- Deploys in under 2 seconds

A Step Above the Rest**Model VS-20-5 Features:**

- Mounts in smaller, more restrictive spaces where most other steps can't fit making it ideal for tilt cabs and other apparatus with depth limitations, such as cylindrical air filters (see below)
- Powered by a 12v electric actuator with a patented over-center locking mechanism to hold extended step rigidly in place
- Step may be wired into the door interlock system to automatically extend when door opens and retract when door is closed
- May be retrofitted onto existing apparatus
- Low maintenance
- Made from high strength aluminum alloy and steel for durability
- Powder-coated and plated for corrosion resistance

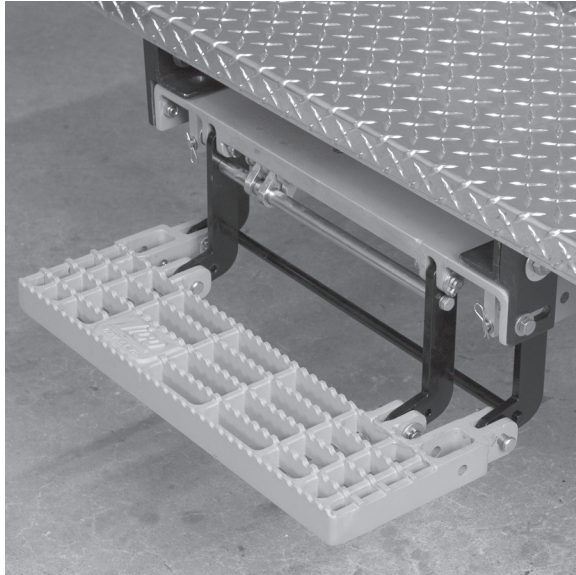

MODEL	DESCRIPTION	WT./@ IN LBS.
VS-20-5	Retractable Vehicle Step	28

Dimensions

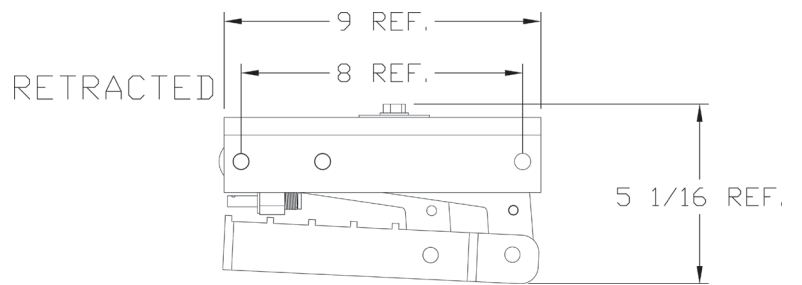
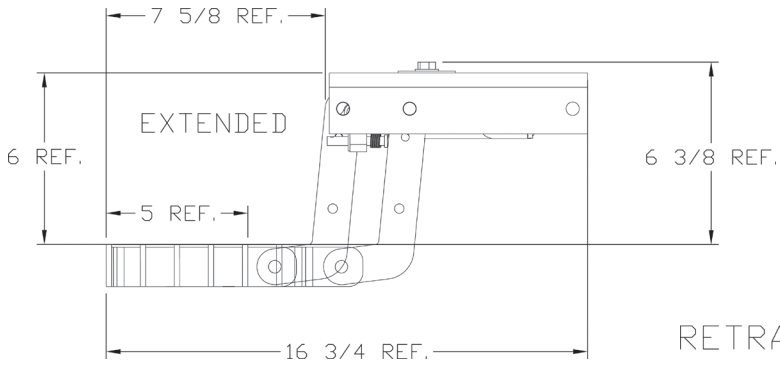
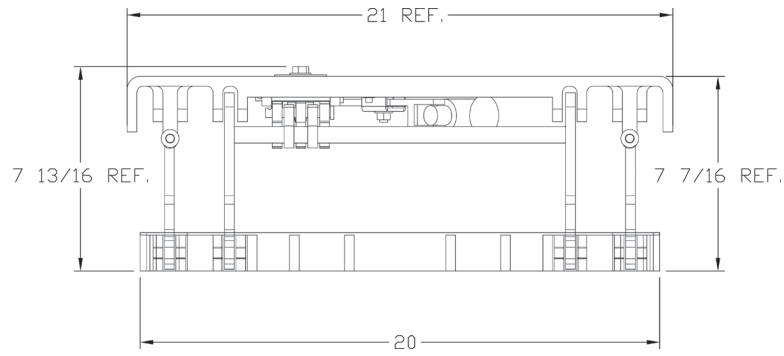

Figure 1 - Motor Controller



LOGIC				
DOOR	SWITCH	ACTUATOR POLARITY	ACTUATOR	STEP
OPEN	CLOSED	RED (+) BLK (-)	RETRACTS	EXTENDS
CLOSE	OPEN	RED (-) BLK (+)	EXTENDS	RETRACTS

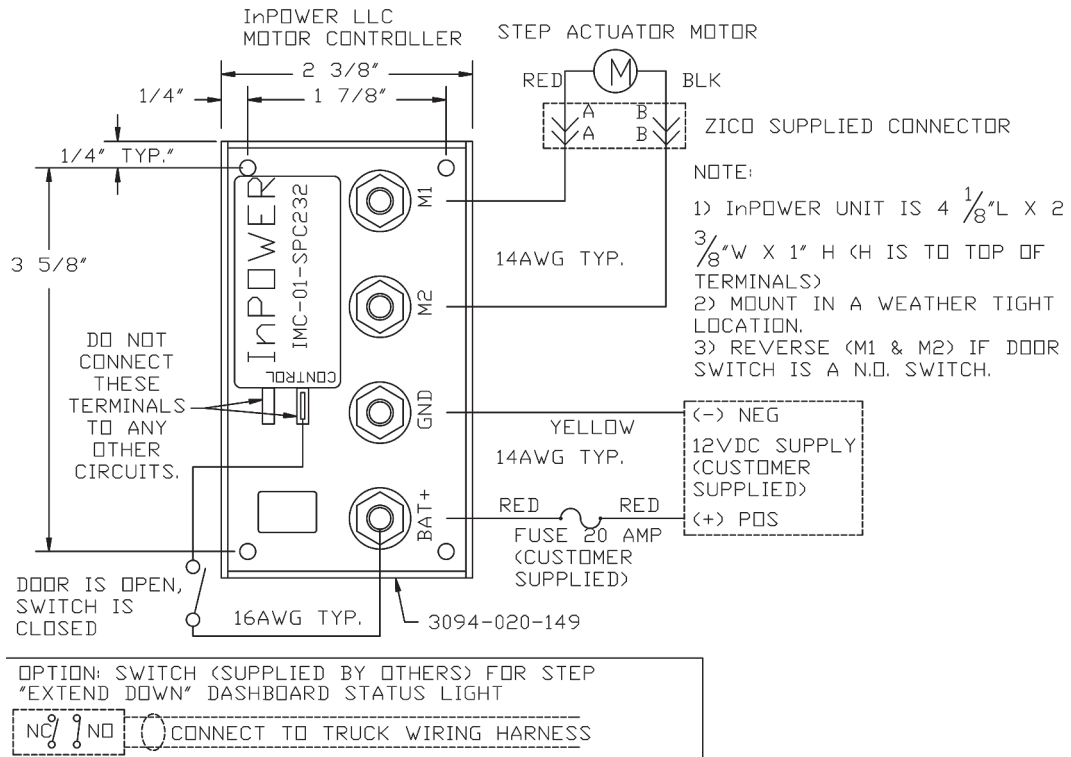

Figure 2 - Field Wiring Diagram

WARNING

ELECTRICAL SHOCK
OR
CRUSHING INJURY

DISCONNECT FROM POWER
BEFORE SERVICING

Failure to do so could result
in serious injury or death

Note: Switch and electrical panel should be mounted in waterproof compartments. Once all electrical connections are complete and system has been tested, protect connections with a weather proofer like liquid tape.

MODE OF OPERATION

- PROVIDE POWER TO AUTOSTEP

EXTEND MODE:

- STEP WILL AUTOMATICALLY EXTEND AS SOON AS THE DOOR IS OPENED.
- STEP WILL REMAIN EXTENDED AS LONG AS DOOR REMAINS OPEN.

RETRACTED MODE:

- STEP WILL AUTOMATICALLY RETRACT AS SOON AS THE DOOR IS CLOSED.
- STEP WILL REMAIN RETRACTED AS LONG AS DOOR REMAINS CLOSED.

Parts Breakdown

ITEM NO.	PART NO.	DESCRIPTION	QTY.
1	3094-020-109	Short Step Spacer	1
2	3094-020-111	Short Step Linear Link C	1
3	3094-020-115	Short Step Bridge	1
4	3094-020-101	Short Step Base	1
5	3094-020-119	Short Step Rod A (12.750")	1
6	3094-020-105	Short Step Arm Weldment	1
7	3094-020-121	Step Linear Link B	1
8	3094-020-117	Short Step Arm	4
9	3094-020-107	Short Step Actuator Mount	1
10	3094-020-123	Short Linear Link A	1
11	3094-020-125	Short Step Universal link	1
12	3094-020-103	Short Step Tread	1
13	9012-203100	5/16 Jam Nut	2
15	9170-001212	Cotter Pin, 1/8 x 3/4; SS	16
16	9114-113100	Washer, 5/16" Nom. S.S.	6
17	3094-020-113	Actuator	1
18	3094-020-129	Short Step Lock Joint B	2
19	3094-020-131	Nylon Washer, 2" O.D., .388" I.D. 1/16" Thick.	2
20	9010-622506	Shoulder Bolt 1/4-20 x 3/8 x 1.625	1
21	9014-113700	Washer, 3/8ø Nom. ZPS	9
22	9114-112500	Washer, 1/4ø Nom.	5
23	9013-172500	Low Profile Nylock Nut, 1/4-20	1
24	9014-202500	Lock Washer, 1/4ø	8
25	9015-103116	Screw, 5/16-24 x 1, Hex Hd., SS	2
26	9018-462516	Screw, Flat Hd. 1/4-20 x 1" Gr. 8	4
27	9015-172500	Nut, 1/4"-20	4
28	9110-363128	Screw C'Sink 5/16-18 x 1-3/4"	1
29	9012-103100	Nut, 5/16"-18	1
30	9080-004332	Clevis Pin, 7/16 x 2"	8

ITEM NO.	PART NO.	DESCRIPTION	QTY.
31	9170-000608	Cotter Pin, 1/16" x 1/2", S.S.	3
32	9080-003720	Clevis Pin, 3/8" x 1-1/4"	1
33	9080-002512	Clevis Pin, 1/4" x 3/4"	1
34	9010-312524	Shoulder Bolt, 1/4" x 1-1/2", 10-24 THRD	1
35	9080-002528	Clevis Pin, 1/4" x 1-3/4"	1
36	3094-020-133	Short Step Lock Joint A	2
37	9080-003752	Clevis Pin, 3/8" x 3-1/4"	1
38	9080-003742	Clevis Pin, 3/8" x 2-5/8"	1
39	3097-105-130	Washer, Nylon 3/8" I.D.	4
40	1027-105-133	Red Bumper	3
41	9010-573132	5/16-18 x 2" Threaded Rod	3
42	3094-005-190	Disconnect Power Tag	1
43	0000-061-020	22-20 Ga. Cavity Seal, Purple	2
44	0000-061-018	22-18 Ga. Cavity Seal, Green	2
45	0000-060-002	Weather Pack Housing, Female	2
46	0000-060-001	Weather Pack Housing, Male	2
47	0000-062-180	20-18 Ga. Weather Pack Terminal, Male	2
48	0000-062-181	20-18 Ga. Weather Pack Terminal, Female	2
49	9014-203100	Lock Washer, 5/16" Nom.	2
50	9113-171900	Nyloc Nut, 10-24	1
51	3094-020-137	Short Step Cover	1
52	9010-101606	#8-32 x 3/8 Screw Ph.	4
53	9014-201600	#8 Lockwasher	4
54	3094-020-147	Actuator Spacer - Gear Box End	2
55	3094-020-145	Actuator Spacer - Ram End	1
56	0000-000-163	Label, Actuator Linkage Maintenance	1
58	3094-020-149	InPOWER LLC Motor Controller	1

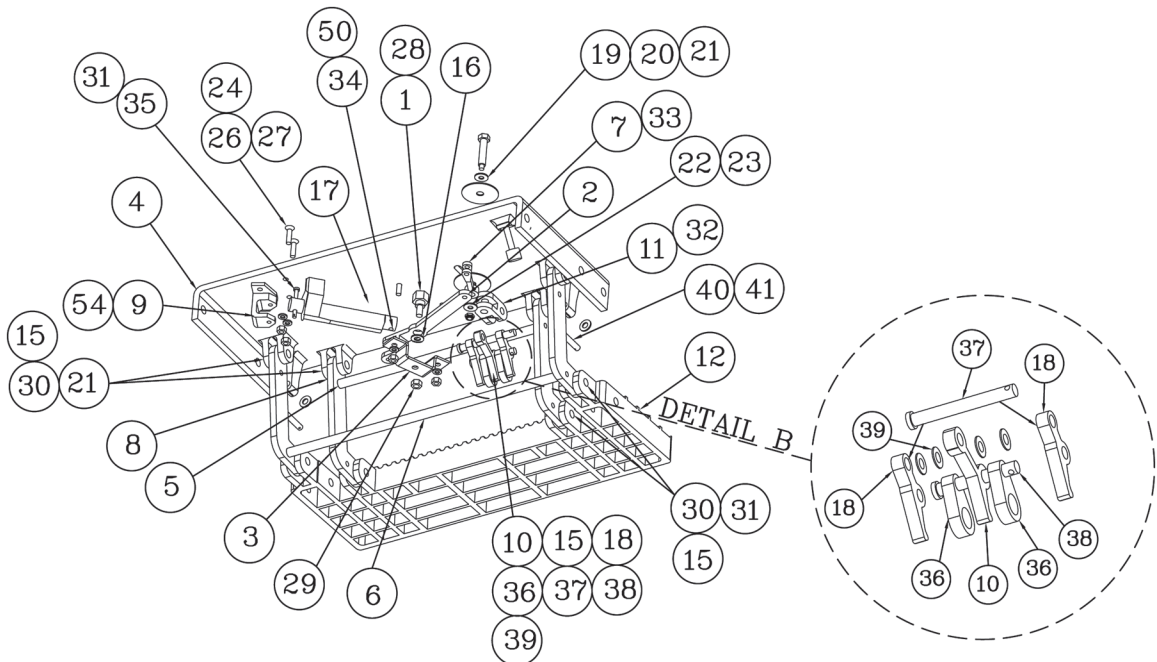
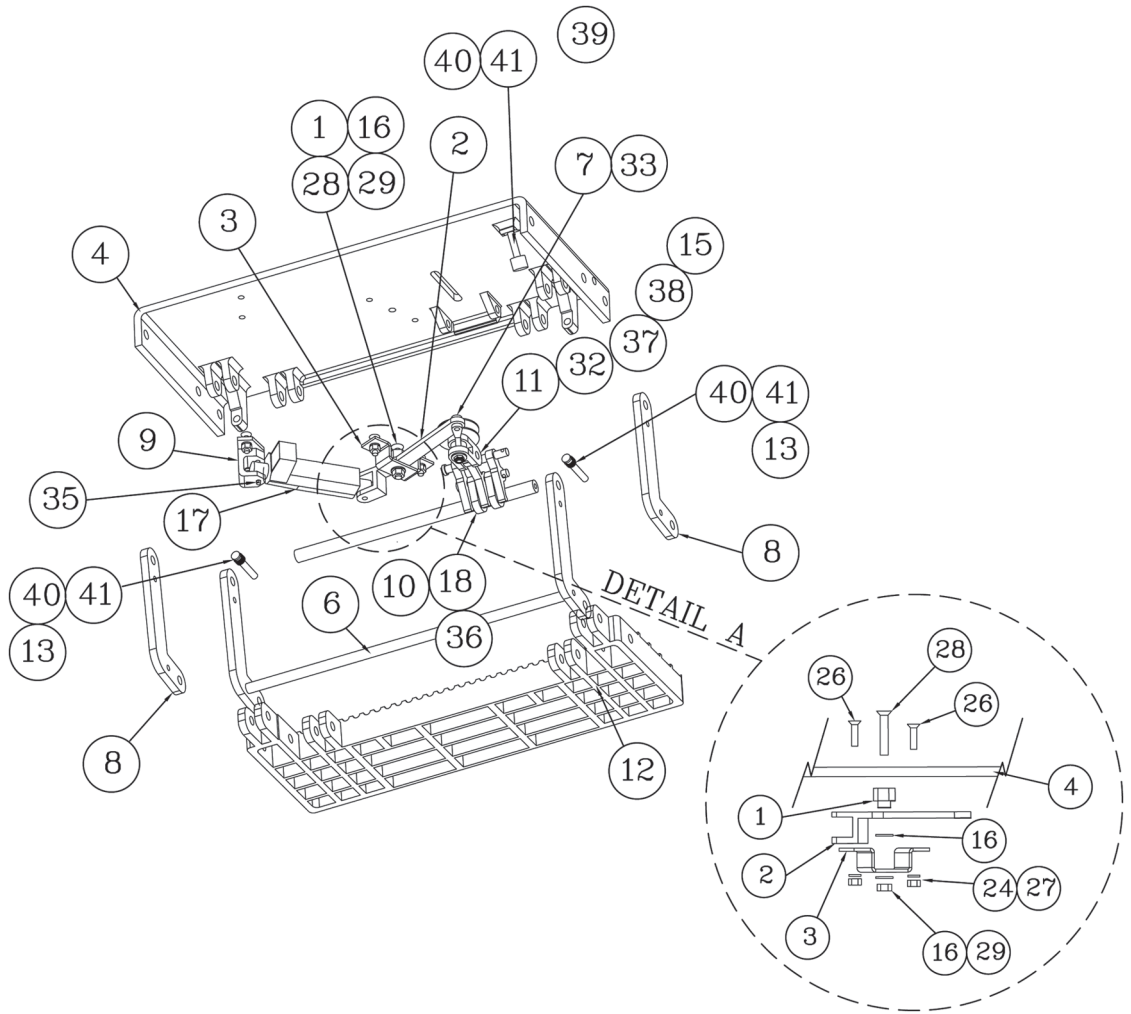

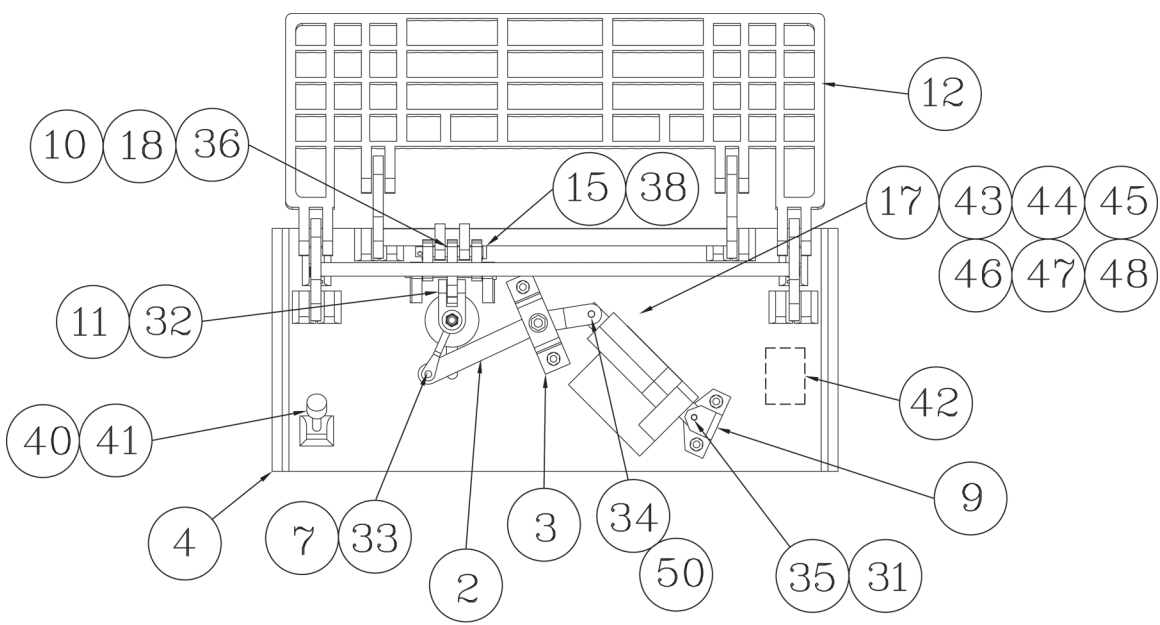
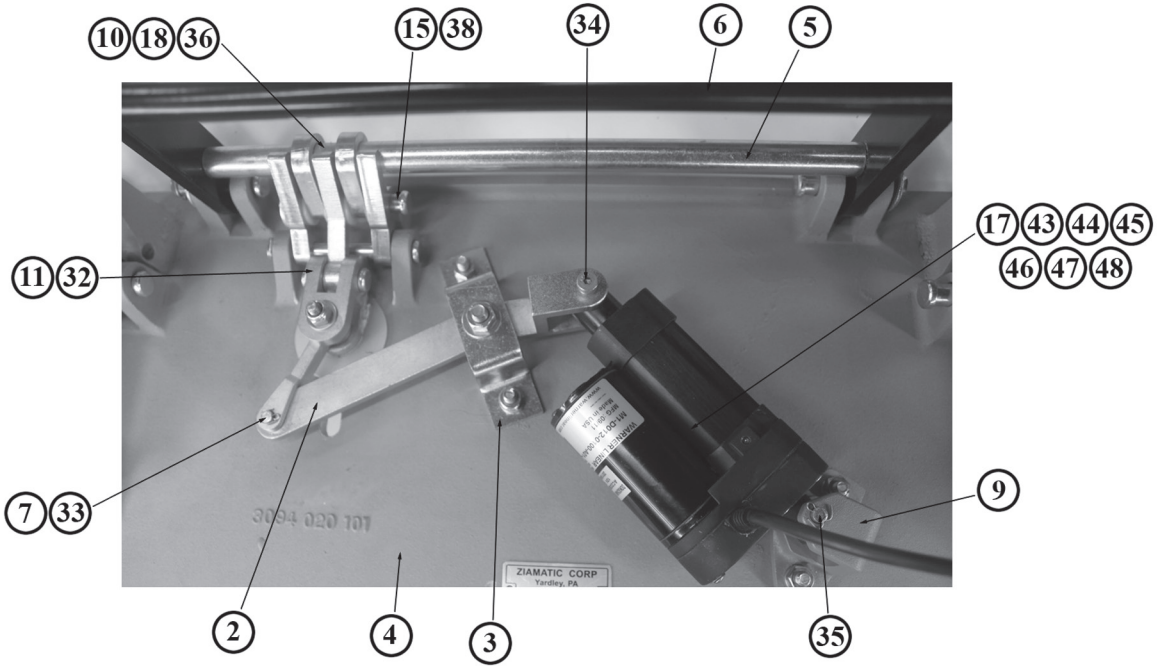

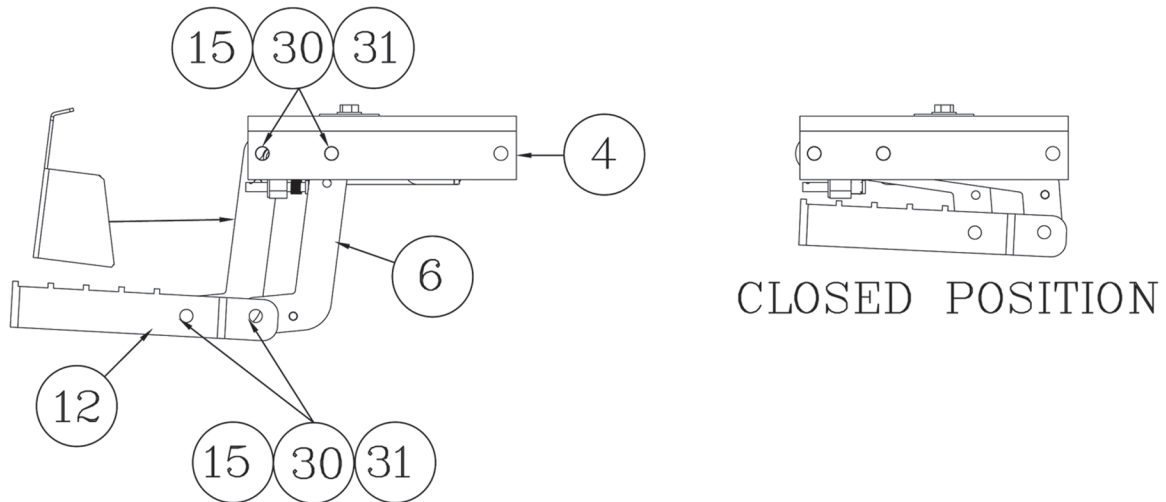

Mounting to Apparatus

- A. An 8" center to center hole pattern is provided in the side flanges of the base casting, centered on the centered on the 9" deep casting. Additional holes may be added as needed.
- B. Because of the component parts elevated above the base casting, a minimum of 1-3/4" is required above the center of the mounting holes.
- C. The length of the base is 21".
- D. Plates extending down from the apparatus structure that the step is mounted to must be strong enough to support 500 lbs. on the extended step.
- E. 3/8" diameter mounting hardware, a minimum of four, is required.

Maintenance

- A. Semi-Annually or at Scheduled Apparatus Lube Service
 - 1. Visually inspect step for excess dirt build-up and debris.
 - 2. Clean parts using mild soap and water. Dry parts thoroughly.
 - 3. Lubricate all joints and pivots with CRC Stor & Lube long-term lubricant and rust preventative #03032. Excess lubrication should be wiped off.
 - 4. Actuator shaft to be lubricated with WD-40 or similar moisture-repelling silicon-type lubricant.



Ziamatic Corp.

10 West College Avenue, P.O. Box 337, Yardley, PA 19067-0587 • (215) 493-3618 • FAX: (215) 493-1401

*ZICO is a registered trademark for fire, safety and marine products made by Ziamatic Corp.

www.ziamatic.com
TOLL FREE: 800-711-3473

Copyright Ziamatic Corp. 8-15