

QUIC-STEP™ RETRACTABLE VEHICLE STEP
MODEL VS-24-11
PARTS AND INSTRUCTION MANUAL

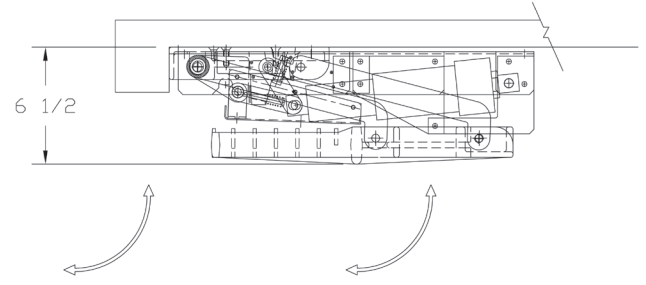

Retracted

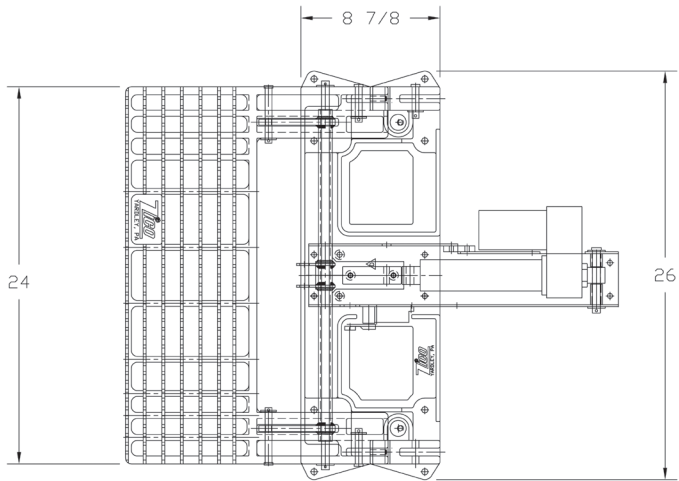
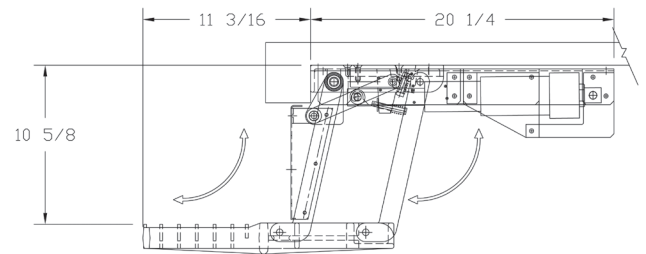

Extended

Designed specifically for use on fire and emergency vehicles. May be retrofitted onto existing apparatus.

Cast aluminum step plate 24" wide x 10-3/4" deep with a non-skid surface to provide traction and safety.



Powered by a single 12-volt electric actuator. Includes a patent pending in-line locking mechanism to hold the extended step rigidly in place.

Step may be wired into door interlock system to automatically extend with door opening and retract with door closing.

Meets NFPA 1901-09 requirements for slip resistance and static load.

MODEL	DESCRIPTION	WT./@ IN LBS.
VS-24-11	Retractable Vehicle Step	71.0

FIGURE 1 - MOTOR CONTROLLER

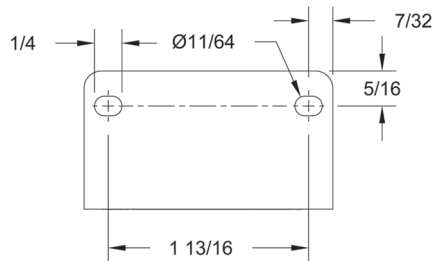
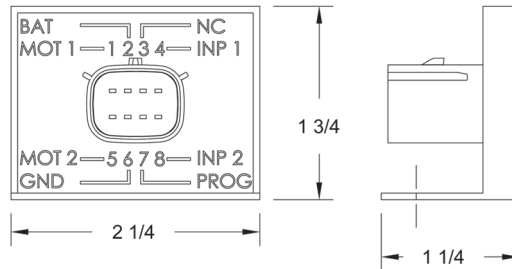
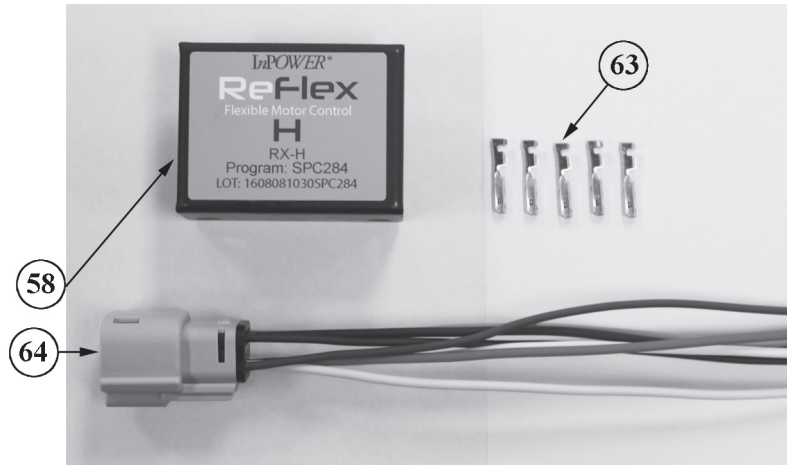

CHART FOR NC SWITCH					
Door Position	Switch	Polarity		Actuator Position	Step
Open	Closed	Pin 1 (-)	Pin 5 (+)	Extends	Goes Down
Closed	Open	Pin 1 (+)	Pin 5 (-)	Retracts	Goes Up

NOTE: REVERSE ACTUATOR MOTOR POLARITY ON INPOWER MODULE (PIN 1 & PIN 5) IF DOOR SWITCH IS A N.O. SWITCH

CONTROL LOGIC

OPTION: SWITCH FOR STEP "EXTEND DOWN" DASHBOARD STATUS LIGHT



InPOWER & PLUG PIN #	InPOWER DESIGNATIONS	DEVICE	DEVICE WIRE COLOR	HARNESS WIRE COLOR
1	MOT 1	MOTOR 1	YELLOW	WHITE
2	BAT	BATTERY (+)	RED	RED
3	NC	NOT USED	N/A	PLUGGED
4	INP 1	DOOR SWITCH	RED	BLUE
5	MOT 2	MOTOR 2	RED	ORANGE
6	GND	BATTERY GND (-)	YELLOW	BLACK
7	PROG	NOT USED	N/A	PLUGGED
8	INP 2	NOT USED	N/A	PLUGGED

NOTE:
1) MOLEX MX150 8-PIN (2X4) FEMALE CONNECTOR 33472-0801

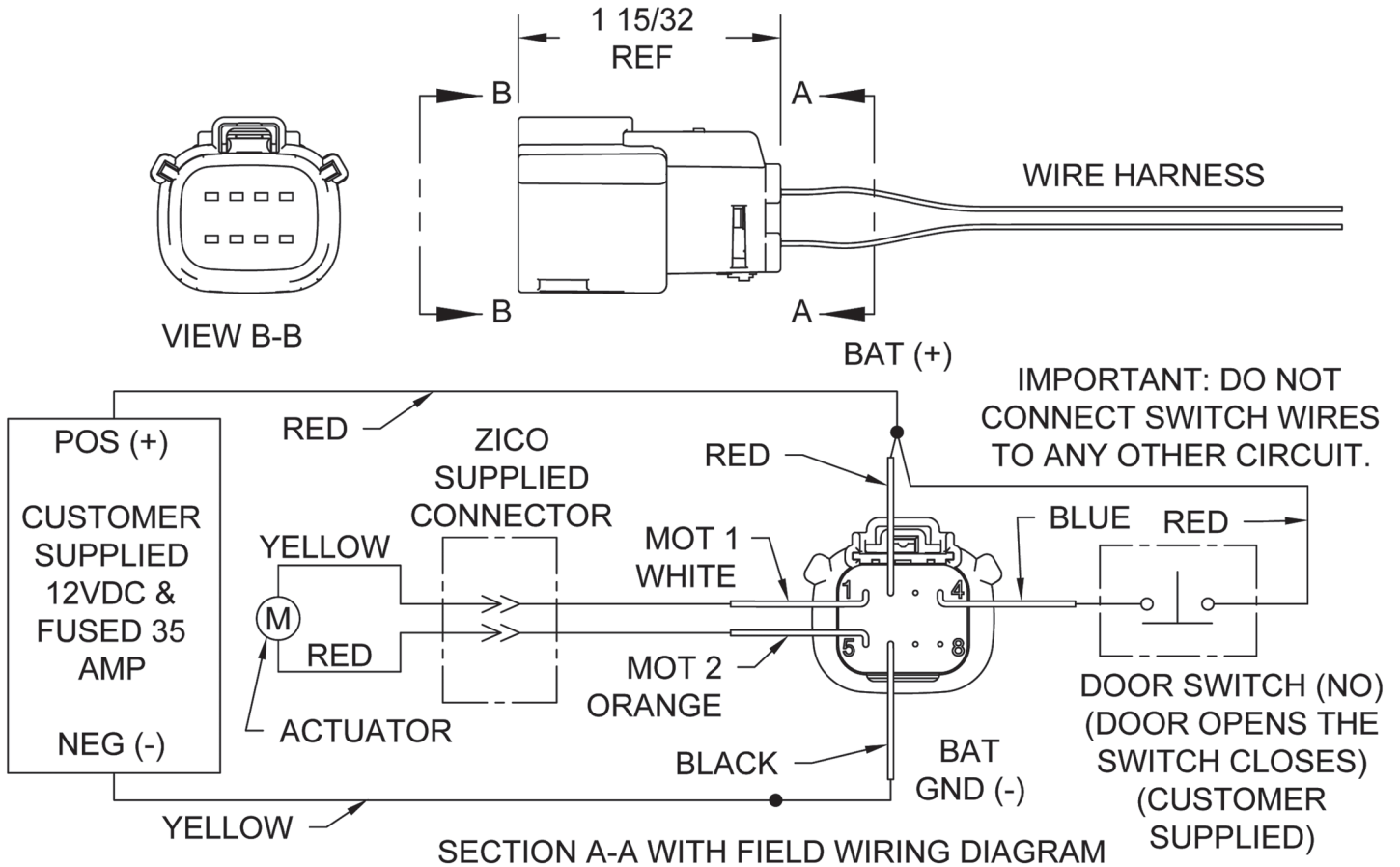

FIGURE 2 - FIELD WIRING DIAGRAM

WARNING

ELECTRICAL SHOCK
OR
CRUSHING INJURY

DISCONNECT FROM POWER
BEFORE SERVICING

Failure to do so could result
in serious injury or death

Note: Switch and electrical panel should be mounted in waterproof compartments. Once all electrical connections are complete and system has been tested, protect connections with a weather proofer like liquid tape.

MODE OF OPERATION

- PROVIDE POWER TO AUTOSTEP

EXTEND MODE:

- STEP WILL AUTOMATICALLY EXTEND AS SOON AS THE DOOR IS OPENED.
- STEP WILL REMAIN EXTENDED AS LONG AS DOOR REMAINS OPEN.

RETRACTED MODE:

- STEP WILL AUTOMATICALLY RETRACT AS SOON AS THE DOOR IS CLOSED.
- STEP WILL REMAIN RETRACTED AS LONG AS DOOR REMAINS CLOSED.

CHART 1

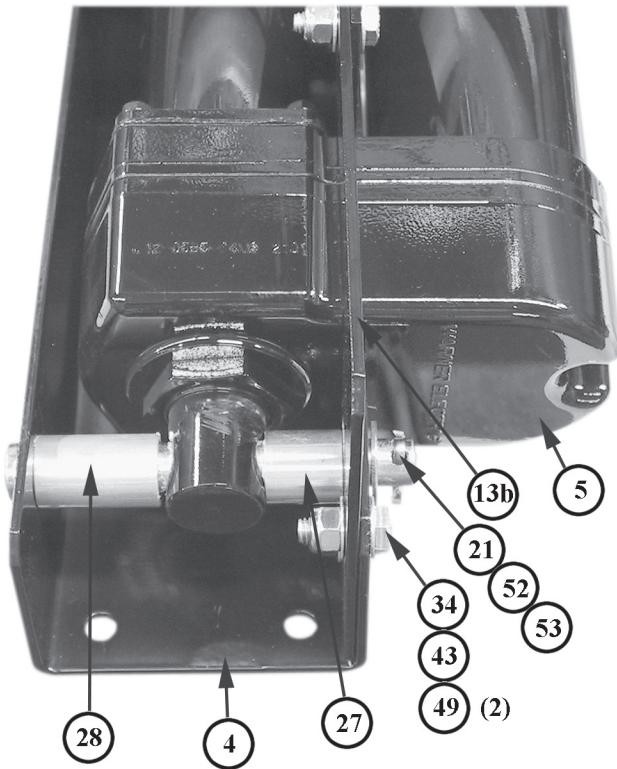

FIGURE 3 - ACTUATOR

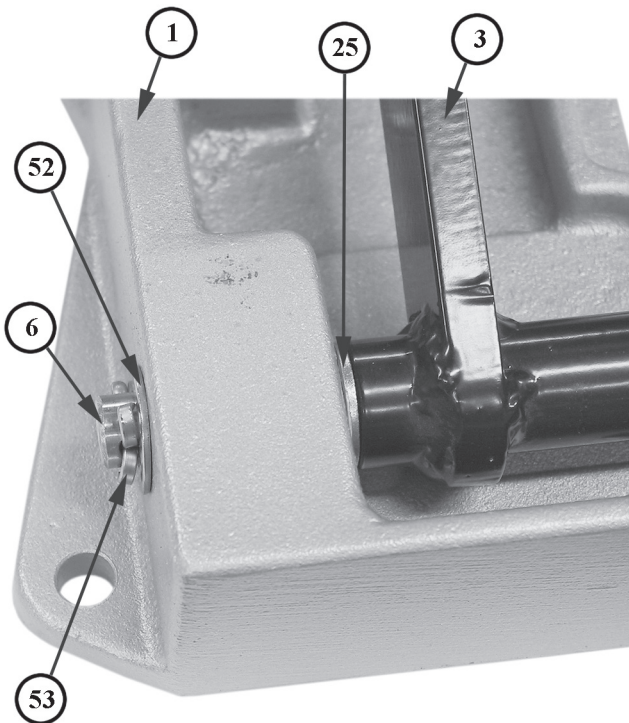
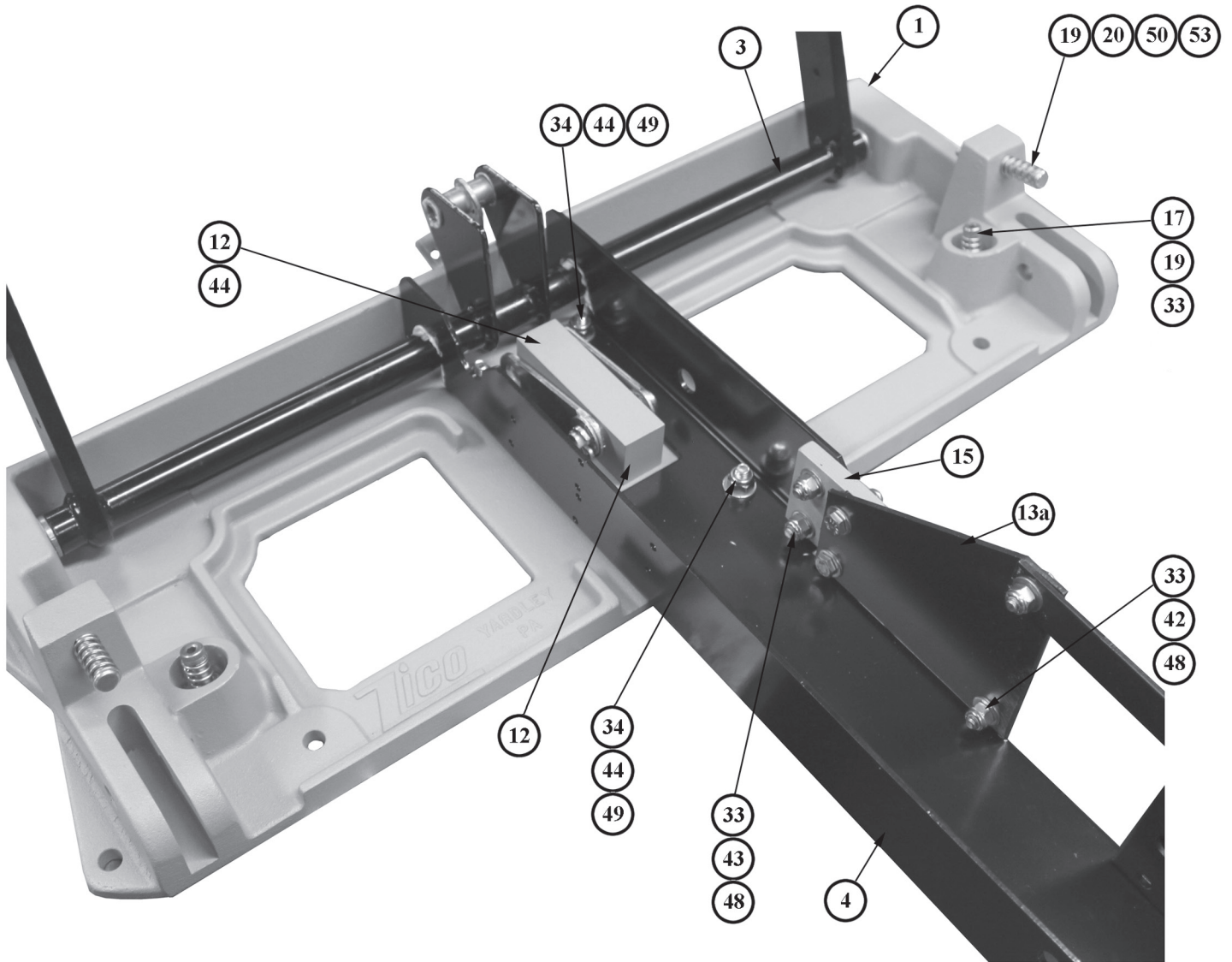
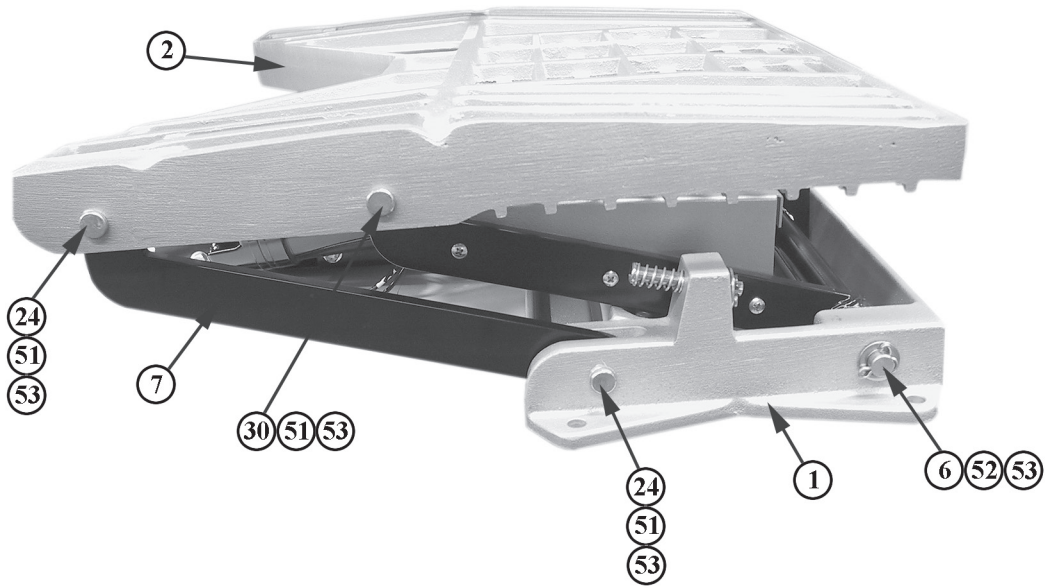

FIGURE 4 - TORQUE TUBE

ITEM	PART NO.	DESCRIPTION	QTY.
1	3094-005-101	BASE CASTING	1
2	3094-030-103	STEP CASTING	1
3	3094-005-105	TORQUE TUBE WELDMENT	1
4	3094-005-133	ACTUATOR ATTACH. BRACKET	1
5	3094-005-113	LINEAR ACTUATOR	1
6	3094-005-115	SHAFT, 1/2ø x 24"	1
7	3094-005-117	SLAVE ARM	2
8	3094-005-119	SHORT LINK	2
9	3094-005-121	LONG LINK	2
10	3094-005-123	KICK PANEL	1
11	3094-005-125	KICK PANEL BRACKET	1
12	3094-005-135	MOUNTING BLOCK, LINKAGE	1
13a	3094-005-137	STIFFENING PLATE A	1
13b	3094-005-138	STIFFENING PLATE B	1
15	3094-005-143	SPACER PLATE	1
17	9110-313116	SHOULDER SCREW, 5/16-18 x 1 S/S	2
18	9010-315032	SHOULDER SCREW, 1/2 - 13 x 2/3/8-16TH.	1
19	3094-005-180	SPRING BUMPER	4
20	9080-003136	CLEVIS PIN, 5/16 x 2-1/4	2
21	9080-005064	CLEVIS PIN, 1/2ø x 4	1
22	9080-003730	CLEVIS PIN, 3/8 x 1-7/8	1
23	0000-061-020	22-20 GA. CAVITY SEAL, PURPLE	2
24	9080-004332	CLEVIS PIN, 7/16 x 2	4
25	3094-005-182	BUSHING SHAFT, .500 ID x 5/8 OD, .1 FL, BRONZE	2
26	3094-005-184	SLEEVE, 3/8 ID x 5/8 OD x 1.625 LG., SS	1
27	3094-005-186	SPACER, .75 OD, .781 LG. x .083 WALL, ALUM. TBG.	1
28	3094-005-188	SPACER, .75 OD x 1.25 LG. x .083 WALL, ALUM. TBG.	1
29	0000-061-018	20-18 GA. CAVITY SEAL, GREEN	2
30	9080-004356	CLEVIS PIN, 7/16 x 3-1/2	2
32	9113-171900	HEX NUT, 10-24, ESNA LOCKNUT S/S	8
33	9113-172500	HEX NUT, 1/4-20, ESNA LOCKNUT S/S	10
34	9113-173100	HEX NUT, 5/16-18, ESNA LOCKNUT S/S	6
35	9018-173700	HEX NUT, 3/8-16, ESNA LOCKNUT GR. 8	1
36	9112-203700	HEX NUT, 3/8-16, JAM S/S	1
37	0000-060-002	WEATHER PACK HOUSING, FEMALE	2
40	0000-060-001	WEATHER PACK HOUSING, MALE	2
41	9110-221912	SCREW, #10-24 x 3/4, PHIL. PAN HD. S/S	8
42	9110-102512	SCREW, 1/4-20 x 3/4, HEX HD. S/S	4
43	9110-102516	SCREW, 1/4-20 x 1, HEX HD. S/S	4
44	9018-363116	SCREW, 5/16-18 x 1, FLAT HD. SOCKET GR. 8	6
45	9018-103740	SCREW, 3/8-16 x 2-1/2, HEX HD. GR. 8	1
46	0000-062-180	20-18 GA. WEATHER PACK TERMINAL, MALE	2
47	9114-101900	WASHER #10 NOM S/S	8
48	9114-112500	WASHER, 1/4ø NOM. S/S	16
49	9114-113100	WASHER, 5/16ø NOM. S/S	6
50	9014-113700	WASHER, 3/8ø NOM.	3
51	9114-114300	WASHER, 7/16ø NOM S/S	6
52	9114-105000	WASHER, 1/2ø NOM S/S	4
53	9170-001212	COTTER PIN, 1/8 x 3/4 S/S	11
54	9110-363112	SCREW, 5/16-18 x 3/4, FLAT HD. SOCKET S/S	2
55	9014-133700	WASHER, 3/8ø NOM. GR. 8	2
56	0000-062-181	20-18 GA. WEATHER PACK TERMINAL, FEMALE	2
58	3094-030-137	INPOWER MODULE	1
60	0000-000-112	SERIAL NUMBER LABEL	1
61	9120-101103	DRIVE SCREW #4 x 3/16 TYPE U	2
62	3094-005-190	WARNING LABEL, ELECTRICAL SHOCK	1
63	3094-005-198	TERMINAL, FEMALE, MOLEX 33012-3001	7
64	3094-030-139	WIRE HARNESS	1
65	0000-000-163	LABEL, ACTUATOR LINKAGE MAINTENANCE	1

**FIGURE 5 -
ACTUATOR RETAINER BRACKET**





**FIGURE 8 -
SIDE VIEW
(upside down)**

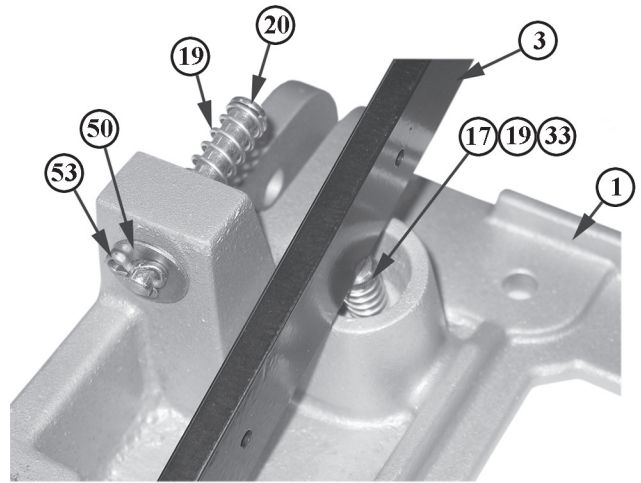
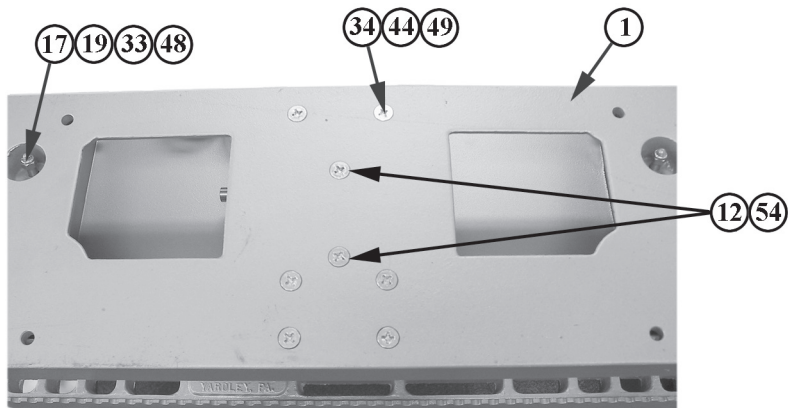

FIGURE 9 - SPRINGS

FIGURE 10 - TOPSIDE OF BASE



SERIAL NUMBER

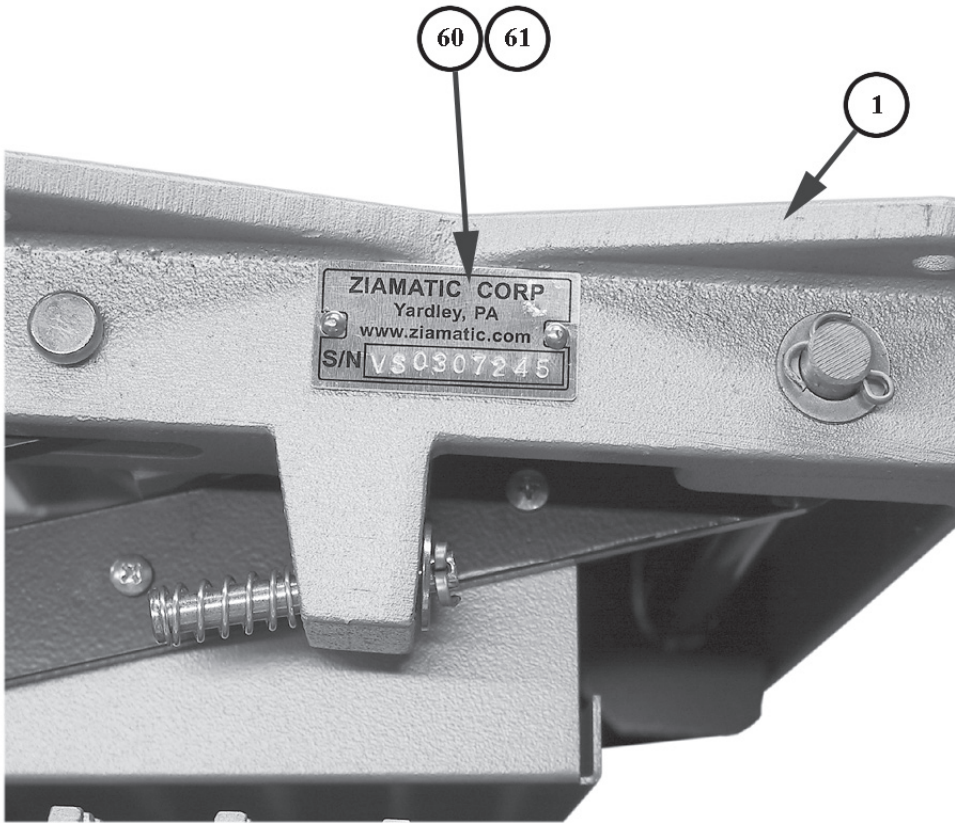

FIGURE 11 - SERIAL NUMBER LABEL

Mounting to Apparatus

- A. A 7-1/16" center to center hole pattern is provided in the side flanges of the base casting. Additional holes may be added as needed.
- B. 3/8" diameter mounting hardware, a minimum of four, is required.
- C. The apparatus structure that the step is mounted to must be strong enough to support 500 lbs. on the extended step.

InPOWER polarity-reversing control module (Item 58) general information:

- When the vehicle door is opened and closed, power will flow to Pins 1 (MOT 1) & 5 (MOT 2) for 4 seconds or the power will stop if the amp demand exceeds 12 amps for 100ms. The polarity will also switch from a nominal +12vdc to a nominal -12vdc as the door is closed and opened.
- If testing the InPOWER unit for voltage across the Pins 1 (MOT 1) & 5 (MOT 2), disconnect the Linear Actuator and connect a 12v test light across the Pins 1 & 5 to cause an amp draw (the unit will not operate without an amp draw). Connect a volt meter across those terminals and either open or close the vehicle door or place a switch between Pin 2 (Bat (+)) and Pin 4 (INP 1). The light should go on momentarily (4 seconds) as the voltage registers a normal 12v. See page 3 "Chart of NC Switch" for the polarity of the pins.

The following tools are recommended if longer wires are to be attached directly to the wire harness plug (Item 64):

Tool for Item 63, female terminals -

- Molex 63811-5900 Crimp Tool, 16-14 GA Female Terminals MX150 Series

Tool for Item 64 wiring harness plug -

- Molex 63813-1500 Extraction Tool, MX150 Series

Wiring the Unit

See pages 2 and 3 for mounting sizes and wiring information.

Note: As the step moves to the fully open or fully closed position, the actuator may make a ratchet sound for a brief moment at the end of the cycle. This is a safety feature of the actuator.

Maintenance

- A. Semi-Annually or at Scheduled Apparatus Lube Service
1. Visually inspect step for excess dirt build-up and debris.
 2. Lubricate all joints and pivots with CRC Stor & Lube long-term lubricant and rust preventative #03032. Excess lubrication should be wiped off.
 3. Electric Actuator - We suggest the exposed shaft be cleaned and sprayed with WD40 or a similar light, moisture-repelling silicone type lubricant.

Note: Maintenance Label (65) located on Kick Panel (10).

- B. Pressure Washing

Do not operate pressure washer around or near the electric actuators. Excessive pressure may allow soap and water to blow past the seal, damaging the actuator.



Ziamatic Corp.

10 West College Avenue, P.O. Box 337, Yardley, PA 19067-0587 • (215) 493-3618 • FAX: (215) 493-1401

www.ziamatic.com

TOLL FREE: 800-711-3473

*ZICO is a registered trademark for fire, safety and marine products made by Ziamatic Corp.

Copyright Ziamatic Corp. 1-17

WARRANTY REGISTRATION

PLEASE MAIL OR FAX A COPY TO ZICO AT 866-493-1401 TO REGISTER YOUR UNIT

FIRE DEPARTMENT NAME: _____ CONTACT PERSON: _____

PHONE NO. _____ FAX NO. _____

STREET ADDRESS: _____ P.O. BOX: _____

CITY: _____ STATE: _____ ZIP: _____

UNIT MODEL NO.: _____

SERIAL NO. ON UNIT: (SEE PAGE 8 FOR LOCATION) _____

INSTALLED ON: (VEHICLE MFG.) _____ DELIVERED: (DATE) _____

WAS UNIT INSTALLED ON: _____ NEW VEHICLE

_____ RETROFITTED ONTO EXISTING VEHICLE

WHERE DID YOU HEAR ABOUT OUR PRODUCT?

_____ MAGAZINE AD (SPECIFY) _____

_____ DEALER (SPECIFY) _____

_____ VEHICLE MFG. (SPECIFY) _____

_____ ANOTHER DEPARTMENT (SPECIFY) _____

_____ OTHER (SPECIFY) _____